

LOCATION: Columbia St -- Mill Plain Blvd
CITY/STATE: Vancouver, WA

QC JOB #: 13418643
DATE: Thu, Jun 11 2015

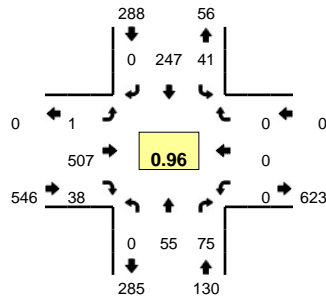

Peak-Hour: 7:15 AM -- 8:15 AM
Peak 15-Min: 7:20 AM -- 7:35 AM

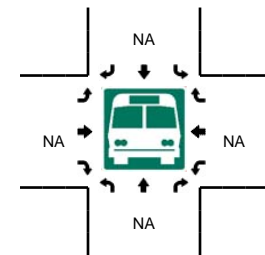
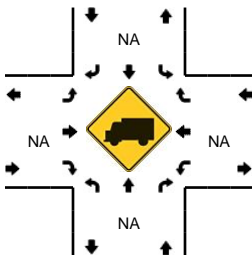
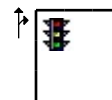
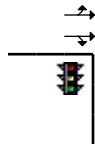
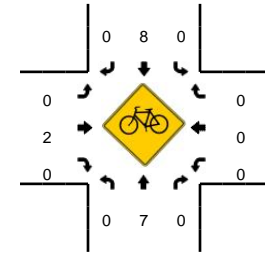
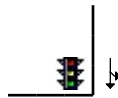
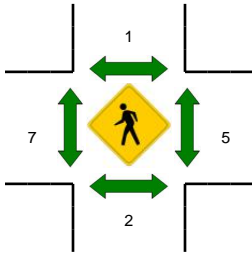
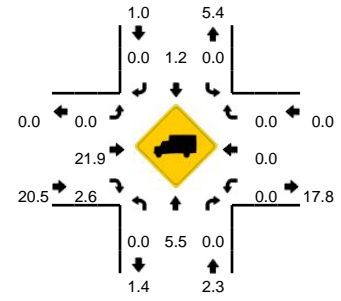

5-Min Count Period Beginning At	Columbia St (Northbound)				Columbia St (Southbound)				Mill Plain Blvd (Eastbound)				Mill Plain Blvd (Westbound)				Total	Hourly Totals	
	Left	Thru	Right	U	Left	Thru	Right	U	Left	Thru	Right	U	Left	Thru	Right	U			
7:00 AM	0	3	6	0	1	20	0	0	0	38	2	0	0	0	0	0	0	70	
7:05 AM	0	5	4	0	1	14	0	0	0	60	3	0	0	0	0	0	0	87	
7:10 AM	0	4	6	0	2	11	0	0	0	29	6	0	0	0	0	0	0	58	
7:15 AM	0	1	11	0	2	12	0	0	0	55	4	0	0	0	0	0	0	85	
7:20 AM	0	8	6	0	3	25	0	0	0	56	3	0	0	0	0	0	0	101	
7:25 AM	0	4	2	0	2	24	0	0	0	25	3	0	0	0	0	0	0	60	
7:30 AM	0	3	7	0	4	25	0	0	0	45	5	0	0	0	0	0	0	89	
7:35 AM	0	5	4	0	5	16	0	0	0	40	3	0	0	0	0	0	0	73	
7:40 AM	0	6	3	0	2	13	0	0	0	45	3	0	0	0	0	0	0	72	
7:45 AM	0	4	7	0	3	26	0	0	0	42	3	0	0	0	0	0	0	85	
7:50 AM	0	5	5	0	5	28	0	0	0	29	5	0	0	0	0	0	0	77	
7:55 AM	0	5	5	0	5	22	0	0	1	41	1	0	0	0	0	0	0	80	937
8:00 AM	0	4	2	0	3	16	0	0	0	50	2	0	0	0	0	0	0	77	944
8:05 AM	0	4	11	0	2	20	0	0	0	40	2	0	0	0	0	0	0	79	936
8:10 AM	0	6	12	0	5	20	0	0	0	39	4	0	0	0	0	0	0	86	964
8:15 AM	0	7	3	0	1	11	0	0	0	39	3	0	0	0	0	0	0	64	943
8:20 AM	0	8	7	0	3	21	0	0	0	37	1	0	0	0	0	0	0	77	919
8:25 AM	0	10	1	0	7	19	0	0	0	40	0	0	0	0	0	0	0	77	936
8:30 AM	0	1	7	0	4	23	0	0	0	40	1	0	0	0	0	0	0	76	923
8:35 AM	0	4	8	0	4	23	0	0	0	37	3	0	0	0	0	0	0	79	929
8:40 AM	0	2	10	0	3	16	0	0	0	41	2	0	0	0	0	0	0	74	931
8:45 AM	0	6	10	0	3	19	0	0	1	34	1	0	0	0	0	0	0	74	920
8:50 AM	0	7	11	0	2	23	0	0	0	39	6	0	0	0	0	0	0	88	931
8:55 AM	0	5	2	0	2	21	0	0	0	25	0	0	0	0	0	0	0	55	906
Peak 15-Min Flowrates	Northbound				Southbound				Eastbound				Westbound				Total		
	Left	Thru	Right	U	Left	Thru	Right	U	Left	Thru	Right	U	Left	Thru	Right	U			
All Vehicles	0	60	60	0	36	296	0	0	0	504	44	0	0	0	0	0	0	1000	
Heavy Trucks	0	4	0	0	0	12	0	0	0	112	0	0	0	0	0	0	0	128	
Pedestrians	0	0	0	0	0	0	0	0	0	4	0	0	0	4	0	0	0	8	
Bicycles	0	0	0	0	0	3	0	0	0	0	0	0	0	0	0	0	0	3	
Railroad																			
Stopped Buses																			

Comments: N/A