

Olympia Dr Mill Plain Blvd

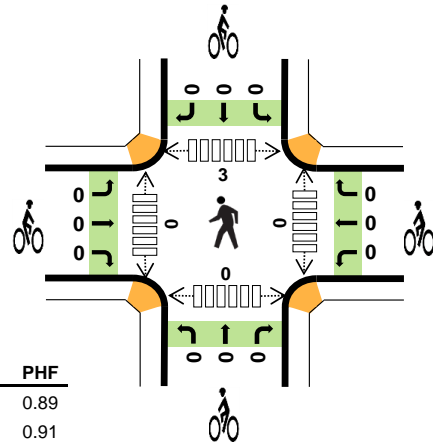

Date: Tue, Sep 21, 2021
 Count Period: 7:00 AM to 9:00 AM
 Peak Hour: 7:45 AM to 8:45 AM

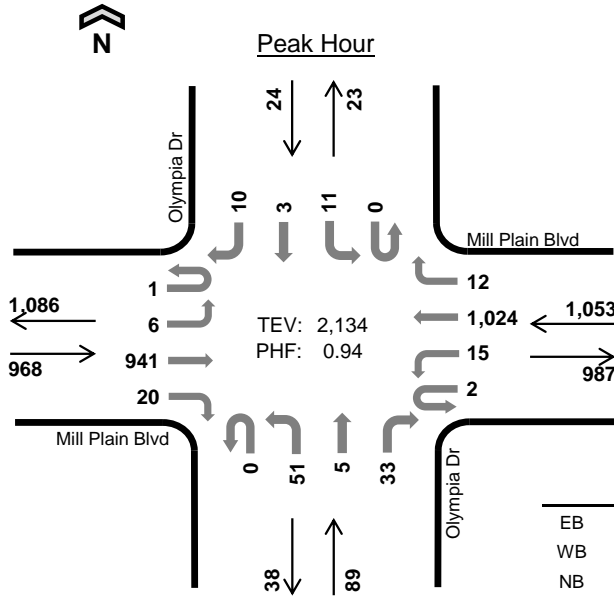

	HV %:	PHF
EB	5.6%	0.89
WB	3.6%	0.91
NB	6.7%	0.72
SB	8.3%	0.67
TOTAL	4.7%	0.94

Two-Hour Count Summaries

Interval Start	Mill Plain Blvd Eastbound				Mill Plain Blvd Westbound				Olympia Dr Northbound				Olympia Dr Southbound				15-min Total	Rolling One Hour	
	UT	LT	TH	RT	UT	LT	TH	RT	UT	LT	TH	RT	UT	LT	TH	RT			
7:00 AM	0	3	142	4	0	2	177	3	0	10	2	4	0	3	1	4	355	0	
7:15 AM	0	0	175	3	0	0	210	3	0	8	2	6	0	2	1	5	415	0	
7:30 AM	0	0	209	2	0	4	254	2	0	16	1	8	0	1	0	3	500	0	
7:45 AM	0	1	225	3	0	2	282	5	0	16	3	12	0	3	3	3	558	1,828	
8:00 AM	0	1	195	5	1	3	222	2	0	18	2	7	0	2	0	1	459	1,932	
8:15 AM	1	3	259	4	0	5	251	4	0	13	0	4	0	3	0	3	550	2,067	
8:30 AM	0	1	262	8	1	5	269	1	0	4	0	10	0	3	0	3	567	2,134	
8:45 AM	1	3	229	6	0	1	262	6	0	9	1	6	0	2	1	1	528	2,104	
Count Total	2	12	1,696	35	2	22	1,927	26	0	94	11	57	0	19	6	23	3,932	0	
Peak Hour	All	1	6	941	20	2	15	1,024	12	0	51	5	33	0	11	3	10	2,134	0
	HV	0	0	51	3	0	0	36	2	0	6	0	0	0	2	0	0	100	0
	HV%	0%	0%	5%	15%	0%	0%	4%	17%	-	12%	0%	0%	-	18%	0%	0%	5%	0

Note: Two-hour count summary volumes include heavy vehicles but exclude bicycles in overall count.

Interval Start	Heavy Vehicle Totals					Bicycles					Pedestrians (Crossing Leg)				
	EB	WB	NB	SB	Total	EB	WB	NB	SB	Total	East	West	North	South	Total
7:00 AM	6	6	0	0	12	0	0	0	0	0	0	1	0	0	1
7:15 AM	9	4	0	2	15	0	0	0	0	0	0	0	0	0	0
7:30 AM	6	9	0	0	15	0	0	0	0	0	0	0	1	1	2
7:45 AM	11	12	2	0	25	0	0	0	0	0	0	0	0	0	0
8:00 AM	12	9	2	1	24	0	0	0	0	0	0	0	0	0	0
8:15 AM	16	13	2	0	31	0	0	0	0	0	0	0	1	0	1
8:30 AM	15	4	0	1	20	0	0	0	0	0	0	0	2	0	2
8:45 AM	15	9	1	0	25	0	0	0	0	0	0	1	0	0	1
Count Total	90	66	7	4	167	0	0	0	0	0	0	2	4	1	7
Peak Hour	54	38	6	2	100	0	0	0	0	0	0	0	3	0	3

Two-Hour Count Summaries - Heavy Vehicles																		
Interval Start	Mill Plain Blvd				Mill Plain Blvd				Olympia Dr				Olympia Dr				15-min Total	Rolling One Hour
	Eastbound				Westbound				Northbound				Southbound					
	UT	LT	TH	RT	UT	LT	TH	RT	UT	LT	TH	RT	UT	LT	TH	RT		
7:00 AM	0	0	6	0	0	0	6	0	0	0	0	0	0	0	0	12	0	
7:15 AM	0	0	9	0	0	0	4	0	0	0	0	0	0	0	1	1	15	0
7:30 AM	0	0	6	0	0	2	7	0	0	0	0	0	0	0	0	0	15	0
7:45 AM	0	0	11	0	0	0	12	0	0	2	0	0	0	0	0	0	25	67
8:00 AM	0	0	9	3	0	0	9	0	0	2	0	0	0	0	1	0	24	79
8:15 AM	0	0	16	0	0	0	11	2	0	2	0	0	0	0	0	0	31	95
8:30 AM	0	0	15	0	0	0	4	0	0	0	0	0	0	0	1	0	20	100
8:45 AM	0	0	15	0	0	1	8	0	0	0	1	0	0	0	0	0	25	100
Count Total	0	0	87	3	0	3	61	2	0	6	1	0	0	0	2	1	167	0
Peak Hour	0	0	51	3	0	0	36	2	0	6	0	0	0	0	2	0	100	0

Two-Hour Count Summaries - Bikes																	
Interval Start	Mill Plain Blvd			Mill Plain Blvd			Olympia Dr			Olympia Dr			15-min Total	Rolling One Hour			
	Eastbound			Westbound			Northbound			Southbound							
	LT	TH	RT	LT	TH	RT	LT	TH	RT	LT	TH	RT					
7:00 AM	0	0	0	0	0	0	0	0	0	0	0	0	0	0	0	0	0
7:15 AM	0	0	0	0	0	0	0	0	0	0	0	0	0	0	0	0	0
7:30 AM	0	0	0	0	0	0	0	0	0	0	0	0	0	0	0	0	0
7:45 AM	0	0	0	0	0	0	0	0	0	0	0	0	0	0	0	0	0
8:00 AM	0	0	0	0	0	0	0	0	0	0	0	0	0	0	0	0	0
8:15 AM	0	0	0	0	0	0	0	0	0	0	0	0	0	0	0	0	0
8:30 AM	0	0	0	0	0	0	0	0	0	0	0	0	0	0	0	0	0
8:45 AM	0	0	0	0	0	0	0	0	0	0	0	0	0	0	0	0	0
Count Total	0	0	0	0	0	0	0	0	0	0	0	0	0	0	0	0	0
Peak Hour	0	0	0	0	0	0	0	0	0	0	0	0	0	0	0	0	0

Note: U-Turn volumes for bikes are included in Left-Turn, if any.