



Interval 60 min. 15 min.
 Binned(CL/SP) Count(volume)
 Lane No 1 2

Direction Channel 1 _____
 Direction Channel 2 _____
 Unique ID# _____

Counter No. 362285 Count ID 20-001
 SR 5 RRT/RRQ Q1 01722 MP 0.00
 Leg 2 Direction NB OSID _____

**COVID PANDEMIC*

DELETE FROM CANSERV - JP

Station Description _ ON SR 5 NB on ramp from La Center rd

| Date | Day | Time | Comments |
|--------|-----|-------|--|
| 9-1-20 | 3 | 0855 | Manual (1) <u>1</u> (2) _____ Counter (1) <u>1</u> (2) _____ Set up ok JDM 6.5v <i>COUNTER SET ON TUESDAY</i> |
| 9-2-20 | 4 | 0909 | Manual (1) <u>1</u> (2) _____ Counter (1) <u>1</u> (2) _____ Check ok JDM 6.9v |
| 9-3-20 | 5 | 1021 | Manual (1) <u>9</u> (2) _____ Counter (1) <u>9</u> (2) _____ Check ok JDM 6.7v |
| 9-4-20 | 6 | 08:41 | Manual (1) <u>1</u> (2) _____ Counter (1) <u>1</u> (2) _____ P/U ok JDM 6.5v |
| | | | Manual (1) _____ (2) _____ Counter (1) _____ (2) _____ |

Sketch

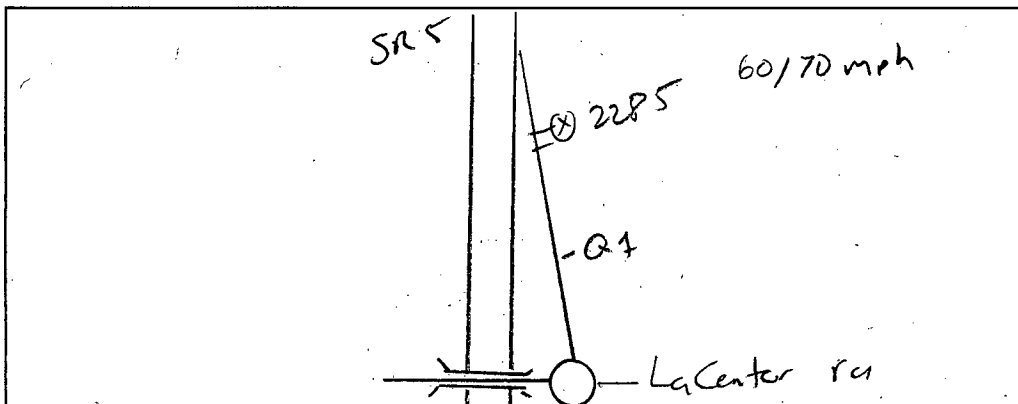

J. Myller
Field Person

3695

STATE OF WASHINGTON - DEPARTMENT OF TRANSPORTATION
 T R I P S S Y S T E M
 HOURLY TRAFFIC CLASSIFICATION SUMMARY

SR 005 Q101722 MP 000.00 OFF SYSTEM ID. LEG 2 DIRECTION OF TRAFFIC NORTHBOUND LANE ALL OF
 COUNT IDENTIFIER 20-001 COUNTER NUMBER 362285 DESCRIPTION: ON SR 5 NB ON RAMP FROM LA CENTER RD

| 09-01-20 TUESDAY AM HOURS | CARS PICKUPS | SINGLE UNITS | | | | SINGLE UNIT % | DOUBLE UNITS | | | DOUBLE UNIT % | TRAINS | | | TRAIN % | TRUCK % | CLASS UNKNOWN | TOTAL VEHICLES |
|---------------------------------|-----------------|--------------|-----|-----|----|------------------|--------------|----|----|------------------|--------|---|----|------------|-------------------|------------------|-------------------|
| | | BUS | MED | HVY | 4+ | | 4- | 5 | 6+ | | 5- | 6 | 7+ | | | | |
| 12 - 1 | | | | | | | | | | | | | | | | | |
| 1 - 2 | | | | | | | | | | | | | | | | | |
| 2 - 3 | | | | | | | | | | | | | | | | | |
| 3 - 4 | | | | | | | | | | | | | | | | | |
| 4 - 5 | | | | | | | | | | | | | | | | | |
| 5 - 6 | | | | | | | | | | | | | | | | | |
| 6 - 7 | | | | | | | | | | | | | | | | | |
| 7 - 8 | | | | | | | | | | | | | | | | | |
| 8 - 9 | | | | | | | | | | | | | | | | | |
| 9 - 10 | 159 | 1 | 11 | 3 | | 7.7 | 7 | 9 | 5 | 10.8 | | | | 18.5 | | | 195 |
| 10 - 11 | 170 | 1 | 12 | 4 | 1 | 8.9 | 6 | 6 | | 5.9 | | | 2 | 1.0 | 15.8 | | 202 |
| 11 - 12 | 210 | 2 | 10 | 6 | | 7.4 | 3 | 7 | 4 | 5.8 | | | | | 13.2 | | 242 |
| PM HOURS | | | | | | | | | | | | | | | | | |
| 12 - 1 | 228 | 2 | 13 | 3 | 1 | 7.4 | 2 | 4 | 2 | 3.1 | | | 1 | .4 | 10.9 | | 256 |
| 1 - 2 | 213 | 3 | 13 | 4 | | 8.1 | 6 | 4 | 5 | 6.0 | | | | | 14.1 | | 248 |
| 2 - 3 | 226 | | 12 | 3 | | 5.7 | 12 | 8 | 1 | 8.0 | | | 1 | .4 | 14.1 | | 263 |
| 3 - 4 | 269 | 2 | 14 | 1 | | 5.8 | 3 | 2 | 2 | 2.4 | | | 2 | .7 | 8.8 | | 295 |
| 4 - 5 | 285 | | 23 | 1 | | 7.4 | 7 | 2 | 6 | 4.6 | | | | | 12.0 | | 324 |
| 5 - 6 | 259 | | 14 | 3 | | 6.0 | | 4 | 1 | 1.8 | | | | | 7.8 | | 281 |
| 6 - 7 | 205 | 1 | 9 | | | 4.5 | 2 | 3 | 1 | 2.7 | | | | | 7.2 | | 221 |
| 7 - 8 | 169 | 1 | 6 | | | 3.9 | 1 | 3 | | 2.2 | | | | | 6.1 | | 180 |
| 8 - 9 | 119 | | 4 | | | 3.2 | | 1 | 1 | 1.6 | | | | | 4.8 | | 125 |
| 9 - 10 | 91 | 1 | 1 | | | 2.1 | 1 | 1 | 1 | 3.1 | | | 1 | 1.0 | 6.2 | | 97 |
| 10 - 11 | 72 | | 4 | | | 5.1 | | 2 | 1 | 3.8 | | | | | 8.9 | | 79 |
| 11 - 12 | 63 | | 1 | | | 1.4 | 1 | 7 | | 11.1 | | | | | 12.5 | | 72 |
| AM TOTAL | 539 | 4 | 33 | 13 | 1 | 8.0 | 16 | 22 | 9 | 7.4 | | | | .3 | 15.6 | | 639 |
| PM TOTAL | 2199 | 10 | 114 | 15 | 1 | 5.7 | 35 | 41 | 21 | 4.0 | | | 1 | .2 | 9.9 | | 2441 |
| DAY TOTAL | 2738 | 14 | 147 | 28 | 2 | 6.2 | 51 | 63 | 30 | 4.7 | | | 1 | .2 | 11.1 | | 3080 |
| | | | | | | | | | | | | | | | 2-AXLE EQUIVALENT | | 3319 |

STATE OF WASHINGTON - DEPARTMENT OF TRANSPORTATION
 TRIP SYSTEM
 HOURLY TRAFFIC CLASSIFICATION SUMMARY

SR 005 Q101722 MP 000.00 OFF SYSTEM ID. LEG 2 DIRECTION OF TRAFFIC NORTHBOUND LANE ALL OF
 COUNT IDENTIFIER 20-001 COUNTER NUMBER 362285 DESCRIPTION: ON SR 5 NB ON RAMP FROM LA CENTER RD

| 09-02-20 | | CARS PICKUPS | SINGLE UNITS | | | | SINGLE UNIT % | DOUBLE UNITS | | | DOUBLE UNIT % | TRAINS | | | TRAIN % | TRUCK % | CLASS UNKNOWN | TOTAL VEHICLES |
|-----------|----------|--------------|--------------|-----|-----|------|---------------|--------------|-----|------|---------------|--------|-----|------|---------|---------|-------------------|----------------|
| WEDNESDAY | AM HOURS | | BUS | MED | HVY | 4+ | | 4- | 5 | 6+ | | 5- | 6 | 7+ | | | | |
| 12 - 1 | 57 | | 1 | | | 1.5 | | 6 | 2 | 12.1 | | | | 13.6 | | 66 | | |
| 1 - 2 | 37 | | | | | | | 1 | | 2.6 | | | | 2.6 | | 38 | | |
| 2 - 3 | 48 | | 3 | | | 5.6 | | 3 | | 5.6 | | | | 11.1 | | 54 | | |
| 3 - 4 | 34 | | 2 | | | 4.9 | 1 | 2 | | 7.3 | 1 | 1 | 4.9 | 17.1 | | 41 | | |
| 4 - 5 | 37 | 1 | 4 | 1 | | 11.8 | | 4 | 2 | 11.8 | 1 | 1 | 3.9 | 27.5 | | 51 | | |
| 5 - 6 | 81 | 1 | 11 | 1 | | 12.3 | 2 | 5 | 3 | 9.4 | | 2 | 1.9 | 23.6 | | 106 | | |
| 6 - 7 | 135 | 1 | 14 | | | 8.9 | 1 | 12 | 5 | 10.7 | | | | 19.6 | | 168 | | |
| 7 - 8 | 179 | | 20 | 2 | | 10.1 | 7 | 2 | 7 | 7.4 | | | | 17.5 | | 217 | | |
| 8 - 9 | 159 | 2 | 13 | 4 | | 9.5 | 6 | 11 | 4 | 10.6 | | | | 20.1 | | 199 | | |
| 9 - 10 | 121 | 2 | 13 | 2 | | 11.0 | 5 | 8 | 3 | 10.3 | | 1 | .6 | 21.9 | | 155 | | |
| 10 - 11 | 160 | 1 | 21 | 3 | 2 | 13.6 | 3 | 3 | 6 | 6.0 | | | | 19.6 | | 199 | | |
| 11 - 12 | 161 | 1 | 12 | 6 | | 9.8 | 3 | 8 | 3 | 7.2 | | | | 17.0 | | 194 | | |
| PM HOURS | | | | | | | | | | | | | | | | | | |
| 12 - 1 | 176 | 2 | 14 | 1 | 1 | 9.0 | 3 | 3 | | 3.0 | | 1 | .5 | 12.4 | | 201 | | |
| 1 - 2 | 177 | 3 | 13 | 4 | | 9.3 | 3 | 11 | 3 | 7.9 | | | | 17.3 | | 214 | | |
| 2 - 3 | 234 | | 14 | 1 | | 5.7 | 1 | 6 | 5 | 4.6 | | 1 | .4 | 10.7 | | 262 | | |
| 3 - 4 | 277 | 2 | 14 | 2 | | 5.8 | 5 | 7 | 2 | 4.5 | | 2 | .6 | 10.9 | | 311 | | |
| 4 - 5 | 261 | 4 | 19 | | | 7.8 | 1 | 6 | 2 | 3.1 | | 1 | .3 | 11.2 | | 294 | | |
| 5 - 6 | 229 | 1 | 10 | | | 4.5 | 4 | 1 | 2 | 2.8 | | | | 7.3 | | 247 | | |
| 6 - 7 | 194 | 1 | 7 | | | 3.9 | 1 | 1 | | 1.0 | | | | 4.9 | | 204 | | |
| 7 - 8 | 133 | | 6 | | | 4.0 | 1 | 7 | 1 | 6.0 | | 1 | .7 | 10.7 | | 149 | | |
| 8 - 9 | 150 | 1 | 7 | | | 4.8 | | 4 | 3 | 4.2 | | | | 9.1 | | 165 | | |
| 9 - 10 | 80 | | 4 | | | 4.5 | 1 | 3 | | 4.5 | | 1 | 1.1 | 10.1 | | 89 | | |
| 10 - 11 | 56 | | 2 | | | 3.2 | | 4 | | 6.5 | | | | 9.7 | | 62 | | |
| 11 - 12 | 66 | | 4 | | | 5.5 | 1 | 1 | | 2.7 | | 1 | 1.4 | 9.6 | | 73 | | |
| AM TOTAL | | 1209 | 9 | 114 | 19 | 2 | 9.7 | 28 | 65 | 35 | 8.6 | 2 | 5 | .5 | 18.8 | | 1488 | |
| PM TOTAL | | 2033 | 14 | 114 | 8 | 1 | 6.0 | 21 | 54 | 18 | 4.1 | 1 | 7 | .4 | 10.5 | | 2271 | |
| DAY TOTAL | | 3242 | 23 | 228 | 27 | 3 | 7.5 | 49 | 119 | 53 | 5.9 | 2 | 1 | 12 | .4 | 13.8 | | 3759 |
| | | | | | | | | | | | | | | | | | 2-AXLE EQUIVALENT | 4144 |

STATE OF WASHINGTON - DEPARTMENT OF TRANSPORTATION
 TRIP SYSTEM
 HOURLY TRAFFIC CLASSIFICATION SUMMARY

SR 005 Q101722 MP 000.00 OFF SYSTEM ID. LEG 2 DIRECTION OF TRAFFIC NORTHBOUND LANE ALL OF
 COUNT IDENTIFIER 20-001 COUNTER NUMBER 362285 DESCRIPTION: ON SR 5 NB ON RAMP FROM LA CENTER RD

| 09-03-20 THURSDAY AM HOURS | CARS PICKUPS | SINGLE UNITS | | | | SINGLE UNIT % | DOUBLE UNITS | | | DOUBLE UNIT % | TRAINS | | | TRAIN % | TRUCK % | CLASS UNKNOWN | TOTAL VEHICLES |
|----------------------------------|-----------------|--------------|-----|-----|----|------------------|--------------|-----|----|------------------|--------|---|----|------------|-------------------|------------------|-------------------|
| | | BUS | MED | HVY | 4+ | | 4- | 5 | 6+ | | 5- | 6 | 7+ | | | | |
| 12 - 1 | 56 | | 1 | | | 1.7 | | 2 | | 3.4 | | | | | 5.1 | | 59 |
| 1 - 2 | 36 | | | | | | | | | | | | | | | | 36 |
| 2 - 3 | 21 | 1 | | | | 3.8 | | 3 | 1 | 15.4 | | | | | 19.2 | | 26 |
| 3 - 4 | 34 | 2 | 2 | | | 8.9 | 1 | 5 | | 13.3 | | 1 | | 2.2 | 24.4 | | 45 |
| 4 - 5 | 41 | 1 | 4 | 2 | | 13.0 | 1 | 2 | | 5.6 | 1 | | 2 | 5.6 | 24.1 | | 54 |
| 5 - 6 | 83 | 1 | 6 | | | 6.9 | | 6 | 3 | 8.9 | | | 2 | 2.0 | 17.8 | | 101 |
| 6 - 7 | 145 | 3 | 16 | 1 | | 11.3 | 1 | 5 | 5 | 6.2 | | 1 | | .6 | 18.1 | | 177 |
| 7 - 8 | 169 | 2 | 14 | 3 | | 9.3 | 6 | 7 | 4 | 8.3 | | | | | 17.6 | | 205 |
| 8 - 9 | 159 | 4 | 20 | 1 | | 12.4 | 6 | 4 | 6 | 7.9 | | 1 | 1 | 1.0 | 21.3 | | 202 |
| 9 - 10 | 136 | | 12 | 1 | | 8.0 | 4 | 4 | 5 | 8.0 | | 1 | | .6 | 16.6 | | 163 |
| 10 - 11 | 161 | 2 | 17 | 2 | | 10.7 | 3 | 9 | 3 | 7.6 | | | | | 18.3 | | 197 |
| 11 - 12 | 186 | 4 | 14 | 4 | | 9.8 | 5 | 9 | 1 | 6.7 | | | 1 | .4 | 17.0 | | 224 |
| PM HOURS | | | | | | | | | | | | | | | | | |
| 12 - 1 | 182 | 2 | 11 | 1 | | 6.6 | 4 | 7 | 5 | 7.5 | | | 1 | .5 | 14.6 | | 213 |
| 1 - 2 | 201 | 4 | 15 | 1 | | 8.5 | 3 | 5 | 5 | 5.6 | | | | | 14.1 | | 234 |
| 2 - 3 | 208 | 2 | 11 | 2 | | 6.4 | 7 | 2 | 1 | 4.3 | | | | | 10.7 | | 233 |
| 3 - 4 | 268 | | 14 | 3 | | 5.7 | 2 | 5 | 4 | 3.7 | | | 2 | .7 | 10.1 | | 298 |
| 4 - 5 | 281 | | 17 | 2 | | 6.1 | 7 | 4 | 2 | 4.2 | | | | | 10.2 | | 313 |
| 5 - 6 | 250 | 1 | 13 | | | 5.1 | 4 | 4 | 2 | 2.9 | 1 | 1 | | .7 | 8.8 | | 274 |
| 6 - 7 | 201 | | 8 | | | 3.7 | 5 | 2 | | 3.2 | | | | | 6.9 | | 216 |
| 7 - 8 | 162 | | 7 | | | 4.0 | | 4 | 1 | 2.9 | | | 1 | .6 | 7.4 | | 175 |
| 8 - 9 | 131 | 3 | 2 | | | 3.5 | | 5 | 1 | 4.2 | | | | | 7.7 | | 142 |
| 9 - 10 | 90 | | 4 | | | 3.9 | 2 | 5 | 1 | 7.8 | 1 | | | 1.0 | 12.6 | | 103 |
| 10 - 11 | 70 | 3 | 2 | | | 6.0 | 1 | 7 | | 9.6 | | | | | 15.7 | | 83 |
| 11 - 12 | 77 | | 2 | 1 | | 3.5 | | 4 | 1 | 5.8 | | | 1 | 1.2 | 10.5 | | 86 |
| AM TOTAL | 1227 | 20 | 106 | 14 | | 9.4 | 27 | 56 | 28 | 7.5 | 1 | 4 | 6 | .7 | 17.6 | | 1489 |
| PM TOTAL | 2121 | 15 | 106 | 10 | | 5.5 | 35 | 54 | 21 | 4.6 | 2 | 2 | 4 | .3 | 10.5 | | 2370 |
| DAY TOTAL | 3348 | 35 | 212 | 24 | | 7.0 | 62 | 110 | 49 | 5.7 | 3 | 6 | 10 | .5 | 13.2 | | 3859 |
| | | | | | | | | | | | | | | | 2-AXLE EQUIVALENT | | 4238 |

STATE OF WASHINGTON - DEPARTMENT OF TRANSPORTATION
 TRIP SYSTEM
 HOURLY TRAFFIC CLASSIFICATION SUMMARY

SR 005 Q101722 MP 000.00 OFF SYSTEM ID. LEG 2 DIRECTION OF TRAFFIC NORTHBOUND LANE ALL OF
 COUNT IDENTIFIER 20-001 COUNTER NUMBER 362285 DESCRIPTION: ON SR 5 NB ON RAMP FROM LA CENTER RD

| 09-04-20 | | | | | | | | | | | | | | | | | |
|-----------|--------------|-----|------------|-----------|----|---------------|-----------------|----|----|---------------|-----------|---|----|---------|---------|-------------------|----------------|
| FRIDAY | | | | | | | | | | | | | | | | | |
| AM HOURS | CARS PICKUPS | BUS | SINGLE MED | UNITS HVY | 4+ | SINGLE UNIT % | DOUBLE UNITS 4- | 5 | 6+ | DOUBLE UNIT % | TRAINS 5- | 6 | 7+ | TRAIN % | TRUCK % | CLASS UNKNOWN | TOTAL VEHICLES |
| 12 - 1 | 53 | 1 | 1 | | | 3.4 | | 3 | 1 | 6.8 | | | | | 10.2 | | 59 |
| 1 - 2 | 40 | | 2 | | | 4.5 | | 1 | 1 | 4.5 | | | | | 9.1 | | 44 |
| 2 - 3 | 40 | 2 | 2 | | | 8.3 | | 2 | 2 | 8.3 | | | | | 16.7 | | 48 |
| 3 - 4 | 45 | | 1 | | | 1.9 | | 3 | 4 | 13.0 | | | 1 | 1.9 | 16.7 | | 54 |
| 4 - 5 | 47 | | 2 | | | 3.5 | 1 | 3 | 3 | 12.3 | | | 1 | 1.8 | 17.5 | | 57 |
| 5 - 6 | 78 | | 4 | | | 4.1 | 2 | 8 | 4 | 14.4 | | 1 | | 1.0 | 19.6 | | 97 |
| 6 - 7 | 123 | | 11 | 2 | | 8.6 | 5 | 5 | 4 | 9.3 | 1 | | | .7 | 18.5 | | 151 |
| 7 - 8 | 139 | 1 | 19 | 4 | | 13.3 | 3 | 9 | 4 | 8.9 | | | 1 | .6 | 22.8 | | 180 |
| 8 - 9 | | | | | | | | | | | | | | | | | |
| 9 - 10 | | | | | | | | | | | | | | | | | |
| 10 - 11 | | | | | | | | | | | | | | | | | |
| 11 - 12 | | | | | | | | | | | | | | | | | |
| PM HOURS | | | | | | | | | | | | | | | | | |
| 12 - 1 | | | | | | | | | | | | | | | | | |
| 1 - 2 | | | | | | | | | | | | | | | | | |
| 2 - 3 | | | | | | | | | | | | | | | | | |
| 3 - 4 | | | | | | | | | | | | | | | | | |
| 4 - 5 | | | | | | | | | | | | | | | | | |
| 5 - 6 | | | | | | | | | | | | | | | | | |
| 6 - 7 | | | | | | | | | | | | | | | | | |
| 7 - 8 | | | | | | | | | | | | | | | | | |
| 8 - 9 | | | | | | | | | | | | | | | | | |
| 9 - 10 | | | | | | | | | | | | | | | | | |
| 10 - 11 | | | | | | | | | | | | | | | | | |
| 11 - 12 | | | | | | | | | | | | | | | | | |
| AM TOTAL | | 565 | 4 | 42 | 6 | 7.5 | 11 | 34 | 23 | 9.9 | 1 | 1 | 3 | .7 | 18.1 | | 690 |
| PM TOTAL | | | | | | | | | | | | | | | | | |
| DAY TOTAL | | 565 | 4 | 42 | 6 | 7.5 | 11 | 34 | 23 | 9.9 | 1 | 1 | 3 | .7 | 18.1 | 2-AXLE EQUIVALENT | 812 |

09-01-20 THRU 09-04-20

AVERAGE WEEKDAY CLASSIFICATION VOLUMES *****

| AVG WEEKDAY VOLUME | CARS PICKUPS | BUS | SINGLE MED | UNITS HVY | 4+ | SINGLE UNIT % | DOUBLE UNITS 4- | 5 | 6+ | DOUBLE UNIT % | TRAINS 5- | 6 | 7+ | TRAIN % | TRUCK % | CLASS UNKNOWN | TOTAL VEHICLES |
|--------------------|--------------|-----|------------|-----------|----|---------------|-----------------|-----|----|---------------|-----------|---|----|---------|---------|-----------------------|----------------|
| 3295 | | 29 | 220 | 26 | 2 | 7.3 | 56 | 115 | 51 | 5.8 | 3 | 4 | 11 | .5 | 13.6 | | 3809 |
| | | | | | | | | | | | | | | | | AWD 2-AXLE EQUIVALENT | 4198 |

TOTAL HOURS FOR COUNT 71
 2 DAYS FACTOR GROUP R045
 AVG WEEKDAY VOL 3809 X SEASONAL ADJ. FACTOR 0.9700 = ESTIMATED AVG DAILY TRAFFIC 3695

PEAK HOUR PERCENTAGES: K = 8.51 D = 100.00 T = 12.04
 PEAK HOUR LOCATION : VOLUME = 324 DATE: 09/01/20 TIME: 04:00 PM

NOTE: MED HIGH/COUNT HIGH/COVID



Interval 60 min. 15 min.
 Binned(CL/SP) Count(volume)
Lane No 1 2

Direction Channel 1 _____
Direction Channel 2 _____
Unique ID# _____

Counter No. 362290 Count ID 20-001
SR 5 RRT/RRQ P1 01611 MP 0.00
Leg 2 Direction NB OSID _____

** COVID PANDEMIC*

Station Description _ ON SR 5 NB off ramp to La Center rd

| Date | Day | Time | Comments |
|--------|-----|-------|---|
| 9-1-20 | 3 | 0848 | Manual (1) <u>1</u> (2) _____ Set up ok JDM 6.5v Counter (1) <u>1</u> (2) _____ <i>COUNTER SET ON TUESDAY</i> |
| 9-2-20 | 4 | 0907 | Manual (1) <u>1</u> (2) _____ Check ok JDM 6.9v Counter (1) <u>1</u> (2) _____ |
| 9-3-20 | 5 | 1015 | Manual (1) <u>50</u> (2) _____ Check ok JDM 7.0v Counter (1) <u>50</u> (2) _____ |
| 9-4-20 | 6 | 08138 | Manual (1) <u>1</u> (2) _____ P/U ok JDM <u>6.8</u> Counter (1) <u>1</u> (2) _____ |
| | | | Manual (1) _____ (2) _____ Counter (1) _____ (2) _____ |

Sketch

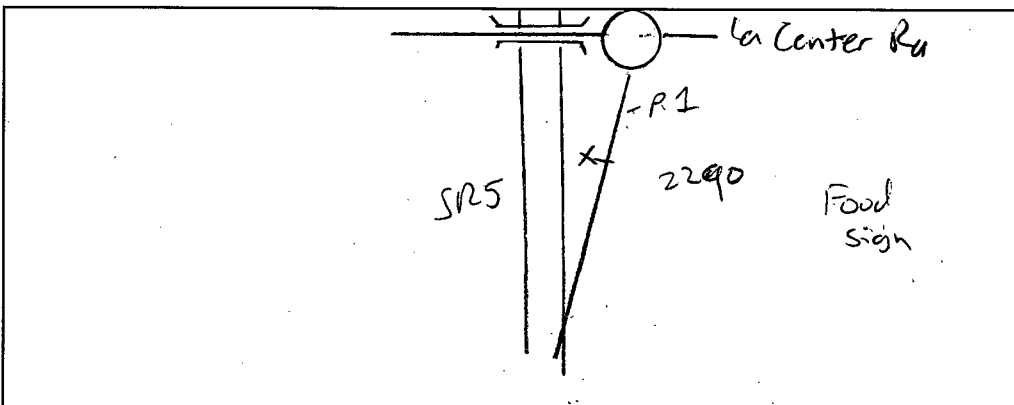

J. Myer
Field Person

STATE OF WASHINGTON - DEPARTMENT OF TRANSPORTATION
TRIPS SYSTEM
15 MINUTE TRAFFIC COUNT SUMMARY

SR 005 P101611 MP 000.00 OFF SYSTEM ID. LEG 2 DIRECTION OF TRAFFIC NORTHBOUND LANE ALL OF

COUNT IDENTIFIER 20-001 COUNTER NUMBER 362290 DESCRIPTION: ON SR 5 NB OFF RAMP TO LA CENTER RD

| 09/01/20 TUESDAY | | AM HOURS | | | | | | | | | | | PM HOURS | | | | | | | | | | | DAILY TOTAL |
|------------------|---|----------|---|---|---|---|---|---|-----|-----|-----|-----|----------|-----|-----|-----|----------------------------------|-----|----------|------|-----|-----|-----|-------------|
| 12 | 1 | 2 | 3 | 4 | 5 | 6 | 7 | 8 | 9 | 10 | 11 | 12 | 1 | 2 | 3 | 4 | 5 | 6 | 7 | 8 | 9 | 10 | 11 | |
| | 1 | 2 | 3 | 4 | 5 | 6 | 7 | 8 | 9 | 10 | 11 | 12 | 1 | 2 | 3 | 4 | 5 | 6 | 7 | 8 | 9 | 10 | 11 | |
| 00-15 | | | | | | | | | 95 | 139 | 140 | 159 | 158 | 167 | 201 | 211 | 219 | 203 | 159 | 126 | 103 | 58 | 68 | |
| 15-30 | | | | | | | | | 94 | 154 | 167 | 178 | 178 | 181 | 190 | 213 | 218 | 209 | 151 | 127 | 97 | 61 | 64 | |
| 30-45 | | | | | | | | | 107 | 181 | 186 | 161 | 173 | 188 | 215 | 204 | 259 | 215 | 148 | 124 | 75 | 80 | 54 | |
| 45-00 | | | | | | | | | 134 | 167 | 200 | 151 | 160 | 195 | 210 | 213 | 228 | 168 | 146 | 125 | 83 | 80 | 48 | |
| HOUR | | | | | | | | | | | | | | | | | | | | | | | | |
| TOT | | | | | | | | | 430 | 641 | 693 | 649 | 669 | 731 | 816 | 841 | 924 | 795 | 604 | 502 | 358 | 279 | 234 | 9166 |
| | | | | | | | | | | | | | | | | | AM PEAK HOUR 1100 TO 1200 VOLUME | 693 | AM TOTAL | 1764 | | | | |
| | | | | | | | | | | | | | | | | | PM PEAK HOUR 0500 TO 0600 VOLUME | 924 | PM TOTAL | 7402 | | | | |

| 09/02/20 WEDNESDAY | | AM HOURS | | | | | | | | | | | PM HOURS | | | | | | | | | | | DAILY TOTAL | |
|--------------------|-----|----------|-----|-----|-----|-----|-----|-----|-----|-----|-----|-----|----------|-----|-----|-----|----------------------------------|-----|----------|------|-----|-----|-----|-------------|-------|
| 12 | 1 | 2 | 3 | 4 | 5 | 6 | 7 | 8 | 9 | 10 | 11 | 12 | 1 | 2 | 3 | 4 | 5 | 6 | 7 | 8 | 9 | 10 | 11 | | |
| | 1 | 2 | 3 | 4 | 5 | 6 | 7 | 8 | 9 | 10 | 11 | 12 | 1 | 2 | 3 | 4 | 5 | 6 | 7 | 8 | 9 | 10 | 11 | | |
| 00-15 | 59 | 37 | 41 | 24 | 17 | 34 | 44 | 63 | 83 | 113 | 161 | 141 | 149 | 152 | 152 | 201 | 208 | 209 | 217 | 127 | 147 | 98 | 53 | 60 | |
| 15-30 | 38 | 37 | 34 | 32 | 26 | 56 | 60 | 82 | 108 | 115 | 150 | 122 | 180 | 161 | 168 | 215 | 177 | 233 | 224 | 148 | 124 | 78 | 74 | 66 | |
| 30-45 | 30 | 26 | 46 | 30 | 44 | 57 | 67 | 125 | 86 | 121 | 168 | 125 | 167 | 169 | 177 | 224 | 178 | 198 | 189 | 128 | 116 | 86 | 77 | 57 | |
| 45-00 | 32 | 14 | 31 | 19 | 29 | 89 | 117 | 124 | 110 | 168 | 148 | 166 | 142 | 172 | 179 | 161 | 204 | 224 | 146 | 103 | 113 | 84 | 72 | 59 | |
| HOUR | | | | | | | | | | | | | | | | | | | | | | | | | |
| TOT | 159 | 114 | 152 | 105 | 116 | 236 | 288 | 394 | 387 | 517 | 627 | 554 | 638 | 654 | 676 | 801 | 767 | 864 | 776 | 506 | 500 | 346 | 276 | 242 | 10695 |
| | | | | | | | | | | | | | | | | | AM PEAK HOUR 0945 TO 1045 VOLUME | 647 | AM TOTAL | 3649 | | | | | |
| | | | | | | | | | | | | | | | | | PM PEAK HOUR 0515 TO 0615 VOLUME | 872 | PM TOTAL | 7046 | | | | | |

| 09/03/20 THURSDAY | | AM HOURS | | | | | | | | | | | PM HOURS | | | | | | | | | | | DAILY TOTAL | |
|-------------------|-----|----------|-----|----|-----|-----|-----|-----|-----|-----|-----|-----|----------|-----|-----|-----|----------------------------------|-----|----------|------|-----|-----|-----|-------------|-------|
| 12 | 1 | 2 | 3 | 4 | 5 | 6 | 7 | 8 | 9 | 10 | 11 | 12 | 1 | 2 | 3 | 4 | 5 | 6 | 7 | 8 | 9 | 10 | 11 | | |
| | 1 | 2 | 3 | 4 | 5 | 6 | 7 | 8 | 9 | 10 | 11 | 12 | 1 | 2 | 3 | 4 | 5 | 6 | 7 | 8 | 9 | 10 | 11 | | |
| 00-15 | 30 | 22 | 41 | 17 | 34 | 35 | 71 | 74 | 110 | 73 | 137 | 151 | 120 | 161 | 156 | 195 | 198 | 187 | 188 | 147 | 128 | 105 | 96 | 94 | |
| 15-30 | 48 | 40 | 52 | 28 | 19 | 70 | 67 | 90 | 114 | 130 | 159 | 160 | 189 | 134 | 166 | 196 | 168 | 207 | 174 | 168 | 140 | 107 | 107 | 92 | |
| 30-45 | 41 | 27 | 63 | 23 | 22 | 81 | 91 | 114 | 98 | 123 | 143 | 129 | 158 | 168 | 167 | 201 | 193 | 211 | 181 | 153 | 138 | 94 | 84 | 92 | |
| 45-00 | 38 | 26 | 36 | 22 | 26 | 109 | 99 | 134 | 145 | 138 | 123 | 172 | 126 | 158 | 170 | 193 | 208 | 189 | 177 | 149 | 95 | 78 | 66 | 58 | |
| HOUR | | | | | | | | | | | | | | | | | | | | | | | | | |
| TOT | 157 | 115 | 192 | 90 | 101 | 295 | 328 | 412 | 467 | 464 | 562 | 612 | 593 | 621 | 659 | 785 | 767 | 794 | 720 | 617 | 501 | 384 | 353 | 336 | 10925 |
| | | | | | | | | | | | | | | | | | AM PEAK HOUR 1100 TO 1200 VOLUME | 612 | AM TOTAL | 3795 | | | | | |
| | | | | | | | | | | | | | | | | | PM PEAK HOUR 0445 TO 0545 VOLUME | 813 | PM TOTAL | 7130 | | | | | |

DOT-RNB515A-B

STATE OF WASHINGTON - DEPARTMENT OF TRANSPORTATION
TRIPS SYSTEM
15 MINUTE TRAFFIC COUNT SUMMARY

DATE 10/22/20
TIME 14:43:21
PAGE 14

SR 005 P101611 MP 000.00 OFF SYSTEM ID: LEG 2 DIRECTION OF TRAFFIC NORTHBOUND LANE ALL OF

COUNT IDENTIFIER 20-001 COUNTER NUMBER 362290 DESCRIPTION: ON SR 5 NB OFF RAMP TO LA CENTER RD

| 09/04/20 FRIDAY | | | | AM HOURS | | | | | | | | PM HOURS | | | | | | | | DAILY TOTAL | | | |
|-----------------|-------|-----|-----|----------|-----|-----|-----|-----|-----|----|----|----------|---|---|---|---|---|---|---|----------------|----|------|----|
| 12 | 1 | 2 | 3 | 4 | 5 | 6 | 7 | 8 | 9 | 10 | 11 | 12 | 1 | 2 | 3 | 4 | 5 | 6 | 7 | | 8 | 9 | 10 |
| 1 | 2 | 3 | 4 | 5 | 6 | 7 | 8 | 9 | 10 | 11 | 12 | 1 | 2 | 3 | 4 | 5 | 6 | 7 | 8 | 9 | 10 | 11 | 12 |
| 00-15 | 53 | 20 | 39 | 23 | 21 | 39 | 96 | 131 | | | | | | | | | | | | | | | |
| 15-30 | 40 | 34 | 34 | 23 | 22 | 61 | 75 | 118 | 141 | | | | | | | | | | | | | | |
| 30-45 | 50 | 34 | 48 | 21 | 39 | 83 | 83 | 149 | | | | | | | | | | | | | | | |
| 45-00 | 48 | 18 | 38 | 32 | 35 | 72 | 94 | 143 | | | | | | | | | | | | | | | |
| HOUR | ----- | | | | | | | | | | | | | | | | | | | | | | |
| TOT | 191 | 106 | 159 | 99 | 117 | 255 | 291 | 506 | 272 | | | | | | | | | | | | | 1996 | |

AM PEAK HOUR 0730 TO 0830 VOLUME 564 AM TOTAL 1996
PM PEAK HOUR 0000 TO 0000 VOLUME 0 PM TOTAL 0

09/01/20 THRU 09/04/20
TOTAL HOURS FOR COUNT 71

2 DAYS FACTOR GROUP R045 FACTOR GROUP R045
AVG WEEKDAY VOL 10810 X SEASONAL ADJ. FACTOR 0.9700 = 10486 X AXLE CORR FACTOR 0.7939 = ESTIMATED AVG DAILY TRAFFIC 8325

PEAK HOUR PERCENTAGES: K = 8.55 D = 100.00
PEAK HOUR LOCATION : VOLUME = 924 DATE: 09/01/20 TIME: 05:00 PM

NOTE: COVID