

SR-14 Bingen/White Salmon Circulation Study

TRANSPORTATION SUMMARY

**December 2018
Final**

Prepared for:



Funded by:

Washington State Department of Transportation

Prepared by:



851 SW 6th Ave, Suite 1600
Portland, OR 97204

In Association with:

Envirolssues
1515 SW 5th Ave #1022
Portland, OR 97201

RTC Respects Civil Rights:

RTC operates its programs without regard to race, color, national origin, religion, sex, sexual orientation, marital status, age or disability in accordance with applicable laws, including Title VI of the Civil Rights Act of 1964 and RCW 49.60. To request additional information on RTC's Title VI nondiscrimination requirements, or if any person believes they have been aggrieved by an unlawful discriminatory practice under Title VI or other applicable law and would like to file a complaint, contact us at 564.397.6067 TTY 711 or email info@rtc.wa.gov.

Persons who do not speak or read English well may request language assistance, oral interpretation and/or written translation, at no cost. Contact RTC at 564.397.6067 TTY 711 or email info@rtc.wa.gov.

Americans with Disabilities Act (ADA) Information:

Individuals requiring reasonable accommodations may request written materials in alternate formats, sign language interpreters, physical accessibility accommodations, or other reasonable accommodations by contacting the ADA Coordinator, Mark Harrington at 546-397-5207 TTY 711, with two weeks advance notice.

TABLE OF CONTENTS

1 Introduction 1

2 Study Area..... 1

3 Stakeholder Input..... 3

4 Existing Conditions 4

 4.1 Trucks4

 4.2 Trains.....4

 4.3 Safety5

 4.4 Public Transit.....6

 4.5 Pedestrian Facilities.....6

 4.6 Bicycle Facilities.....6

 4.7 Parking7

 4.8 24-Hour Traffic Counts8

 4.9 Origin-Destination Data12

 4.10 Intersection Traffic Counts15

 4.11 Traffic Operational Analysis16

 4.11.1 Traffic Operations by Highway Segment16

 4.11.2 Intersection Operations.....18

5 Future Year Assumptions 22

6 Future No Build Conditions..... 22

 6.1 Traffic Volumes22

 6.2 Traffic Operational Analysis23

 6.2.1 Traffic Operations by Highway Segment23

 6.2.2 Intersection Operations24

 6.3 Trucks27

 6.4 Trains.....27

 6.5 Safety27

 6.6 Public Transit.....27

 6.7 Pedestrian Facilities.....28

 6.8 Bicycle Facilities.....28

 6.9 Parking28

 6.10 Hood River Bridge Replacement.....28

7 Future Build Conditions 28

 7.1 Bingen Point Access Study Concept 229

 7.1.1 Future Traffic Volumes and Operational Analysis29

7.2 *Bingen Point Access Study Concept 14* 34

7.3 *Various Improvements to Concept 14* 39

 7.3.1 Concept 14 A1 and Concept 14 A2 40

 7.3.2 Concept 14 B1 and Concept 14 B2 45

 7.3.3 Concept 14 C, Concept 14 D and Concept 14 E 52

7.4 *Summary of all Build Conditions* 53

7.5 *Rail Considerations* 59

8 Conclusion 60

9 References 64

Appendix A – Existing and Future Conditions for Trucks on SR-14 A

Appendix B – Stakeholder Summary Memorandum B

Appendix C – Native Traffic Data C

Appendix D – Synchro Output Summary D

LIST OF FIGURES

Figure 1. Study Area Intersections 2

Figure 2. On-Street Parking Utilization in Bingen 7

Figure 3. 24-Hour Traffic Count Data for SR-14 west of SR-141 Alt (October 2016) 8

Figure 4. 24-Hour Traffic Count Data for SR-14 east of SR-141 Alt (October 2016) 9

Figure 5. 24-Hour Traffic Count Data for SR-14 west of Walnut Street (October 2016) 9

Figure 6. 24-Hour Traffic Count Data for SR-14 between Walnut Street and Alder Street (October 2016) 10

Figure 7. 24-Hour Traffic Count Data for SR-14 east of Bingen City Limits (October 2016) 10

Figure 8. Origin-Destination Bluetooth Reader Locations 13

Figure 9. Origin-Destination Patterns 14

Figure 10. Existing Conditions Traffic Volumes during the PM Peak Hour (2017) 16

Figure 11. SR-14 Highway Segment Levels of Service – Existing Conditions (2017) 18

Figure 12. Existing Conditions Intersection Levels of Service during the PM Peak Hour (2017) 21

Figure 13. Future No Build Traffic Volumes during the PM Peak Hour (2037) 23

Figure 14. SR-14 Highway Segment Levels of Service – Future Conditions (2037) 24

Figure 15. Future No Build Intersection Levels of Service during the PM Peak Hour (2037) 26

Figure 16. Concept 2 Baseline 29

Figure 17. Concept 2 Baseline Traffic Volumes during the PM Peak Hour (2037) 30

Figure 18. Concept 2 Baseline Intersection Levels of Service during the PM Peak Hour (2037) 31

Figure 19. Concept 14 Baseline 34

Figure 20. Concept 14 Baseline (and Concepts 14 A1, 14 B1, 14 C, 14 D, and 14 E) Traffic Volumes during the PM Peak Hour (2037) 35

Figure 21. SR-14 Highway Segment Levels of Service – Concept 14 Baseline (and Concepts 14 A1, 14 A2, 14 B1, 14 B2, 14 C, 14 D and 14 E) 36

Figure 22. Concept 14 Baseline Intersection Levels of Service during the PM Peak Hour (2037) 39

Figure 23. Concept 14 A1 40
 Figure 24. Concept 14 A2 41
 Figure 25. Concept 14 A1 and Concept 14 A2 Intersection Levels of Service during the PM Peak Hour (2037) 45
 Figure 26. Concept 14 B1 46
 Figure 27. Concept 14 B2 46
 Figure 28. Concept 14 B1 and Concept 14 B2 Intersection Levels of Service during the PM Peak Hour (2037) 51
 Figure 29. Concept 14 C 52
 Figure 30. Concept 14 C Intersection Levels of Service during the PM Peak Hour (2037) 56

LIST OF TABLES

Table 1. Roadway Functional Classification and Posted Speed Limits 3
 Table 2. Crashes by Severity (2012-2016) 5
 Table 3. Crashes by Type (2012-2016) 6
 Table 4. 24-Hour Traffic Count Data (October 2016) 11
 Table 5. Origin-Destination Average Daily Counts and Percentages (October 2016) 13
 Table 6. Driving Conditions by Highway LOS 17
 Table 7. LOS Criteria for Intersections 19
 Table 8. Average Vehicle Delay: Existing Conditions during the PM Peak Hour (2017) 20
 Table 9. Average Vehicle Delay: Future No Build Conditions during the PM Peak Hour Compared to Existing Conditions 25
 Table 10. Average Vehicle Delay: Concept 2 Baseline Compared to Existing and Future No Build 32
 Table 11. Average Vehicle Delay: Concept 14 Baseline Compared to Existing and Future No Build 37
 Table 12. Scenarios Analyzed in Combination with Concept 14 40
 Table 13. Average Vehicle Delay: Concept 14 A1 and Concept 14 A2 Compared to Existing, Future No Build, and Concept 14 Baseline during the PM Peak Hour 43
 Table 14. Average Vehicle Delay: Concept 14 B1 and Concept 14 B2 Compared to Existing, Future No Build, and Concept 14 Baseline during the PM Peak Hour 49
 Table 15. Average Vehicle Delay: Concept 14 C, Concept 14 D and Concept 14 E Compared to Existing, Future No Build, and Concept 14 Baseline during the PM Peak Hour 54
 Table 16. Average Vehicle Delay: Comparison of Existing, Future No Build, and All Build Concepts during the PM Peak Hour 57
 Table 17. Average Vehicle Delay: Select Intersections during the PM Peak Hour During Train Crossings (2037) 59

LIST OF ACRONYMS AND ABBREVIATIONS

AADT	Annual Average Daily Traffic
ADT	Average Daily Traffic
FAF	Freight Analysis Framework
FHWA	Federal Highway Administration
HCM	Highway Capacity Manual
LOS	Level of Service
MATS	Mt. Adams Transportation Services
MP	Milepost
mph	Miles Per Hour
VMT	Vehicle Miles of Travel
OFM	Office of Financial Management
RRFB	Rectangular Rapid Flashing Beacon
RTC	Southwest Washington Regional Transportation Council
SR	State Route
WSDOT	Washington State Department of Transportation

1 INTRODUCTION

SR-14 through Bingen and White Salmon has been selected as a study segment to identify potential transportation and circulation improvements. The objective of this study is to perform a planning-level assessment of travel patterns and trends, document existing traffic conditions, identify future transportation needs, and describe possible access and mobility solutions to address current travel impacts and improve circulation. The targeted segment of SR-14 between SR-141 Alternative (Alt) and milepost 67.5 east of the eastern Bingen city limits serves not only residents and employers in the local area but also heavy recreational traffic and tourism-based travelers during warmer months. In addition, substantial freight movement occurs on SR-14 in terms of truck volumes and commodity flow.

The results of the SR-14 Bingen/White Salmon Circulation Study are published in two companion documents.

- This **Transportation Summary** is a comprehensive report that documents the study assumptions, existing and future conditions for all modes (vehicle, truck, transit, pedestrian, bicycle, and rail), historical highway safety data, and existing parking facilities. Detailed data and analysis results, including existing and future freight truck conditions, a stakeholder interview summary, traffic data, and traffic modeling output results are included as appendices.
- The **Briefing Memorandum on Traffic Operations** is a focused discussion concerning vehicular traffic operations by SR-14 highway segment and intersection. The purpose of the memorandum is to brief local decision-makers on overall levels of service along SR-14 and specific movements at intersections that are currently exceeding tolerable delays or will exceed tolerable delays in the future.

2 STUDY AREA

The study area along SR-14 extends from SR-141 Alt to a location just east of the eastern Bingen city limits, as shown in Figure 1. The existing roadway cross section for SR-14 in the study area consists of a two-lane section (one travel lane in each direction) with a center turn lane in specific locations. The study area includes the SR-14 highway and major intersection along SR-14 through Bingen and White Salmon. For the purposes of traffic analysis, the following seven intersections were assessed:

1. SR-14 and SR-141 Alt
2. SR-14 and Dock Grade Road
3. SR-14 and Hood River Bridge (SR-35)
4. SR-14 and Walnut Street
5. SR-14 and Ash Street
6. SR-14 and Oak Street (SR-141)
7. SR-14 and Maple Street

These study area intersections are illustrated in Figure 1.

Figure 1. Study Area Intersections

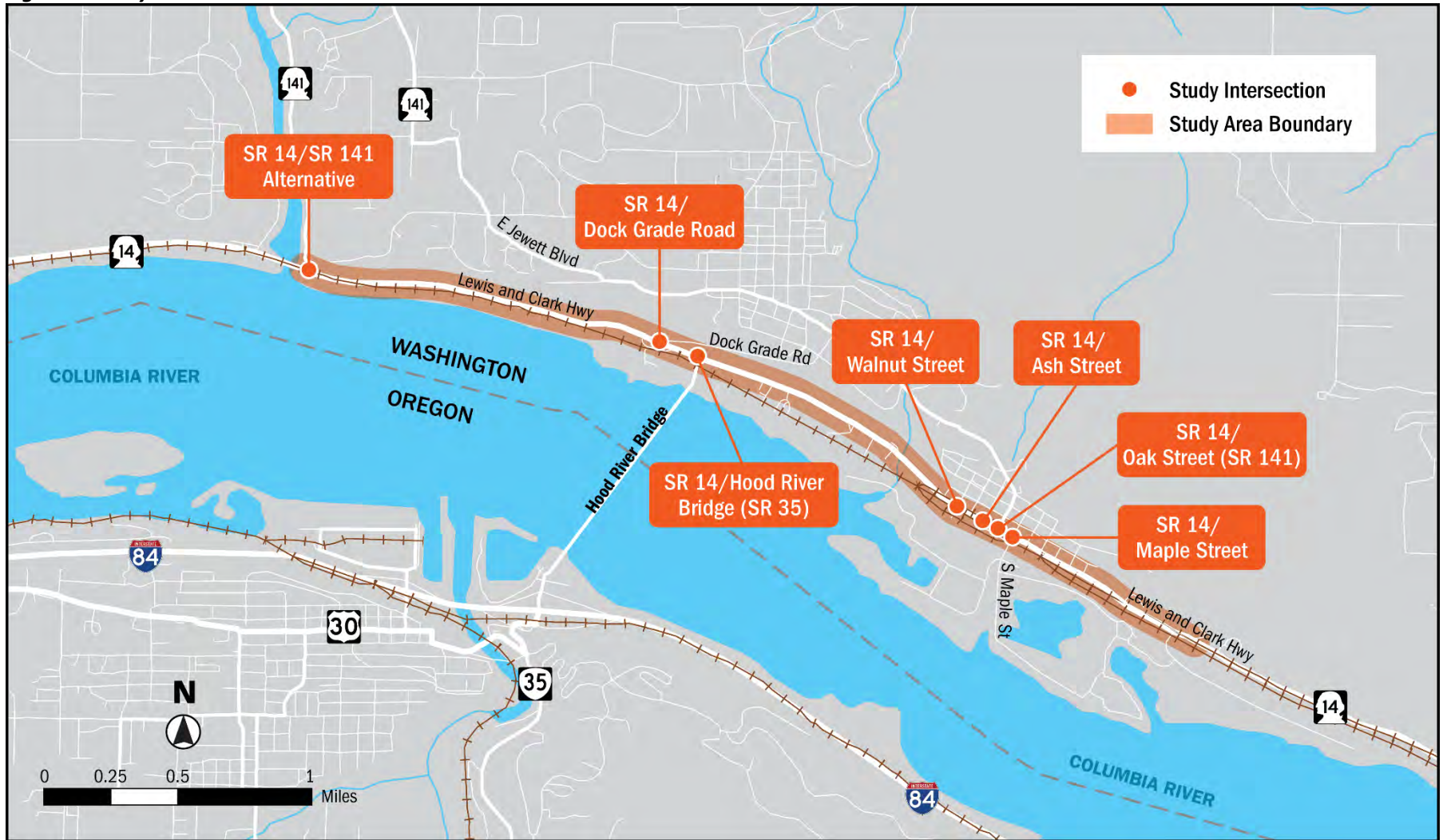

Field visits and aerial imagery (ex. Google Maps, Google Earth) were used to verify existing study area features and elements, including lane configurations, traffic control devices, signal timing, and traffic congestion levels. Table 1 lists roadway classifications based on the WSDOT functional classification map (WSDOT 2018).

Table 1. Roadway Functional Classification and Posted Speed Limits

Roadway Name	Functional Classification	Posted Speed	On-Street Parking	Sidewalks	Bike Lanes
SR-14	Rural Principal Arterial	25-60 mph (varies)	Partial	Partial	No
SR-141 Alt.	Rural Major Collector	45 mph	No	No	No
Dock Grade Road	Rural Major Collector	30 mph	No	No	No
Hood River Bridge	Rural Principal Arterial	25 mph	No	No	No
Walnut Street	Local Road	25 mph	Yes	Partial	No
Ash Street	Rural Minor Collector	25 mph	Yes	Yes	No
Oak Street (SR-141)	Rural Major Collector	25 mph	Yes	Partial	No
Maple Street	Rural Major Collector	25 mph	Yes	Partial	No

Source: Google Earth Pro 2018; WSDOT 2018.

3 STAKEHOLDER INPUT

The Southwest Washington Regional Transportation Council (RTC) has led the SR-14 Bingen/White Salmon Circulation Study with support from WSDOT and other local agencies, which includes gathering input from other key stakeholders in the project area.

Eight interviews were conducted with 10 participants who rely on SR-14 within the study area. These interviews were used to understand key transportation and economic development interests as well as critical pathways for emergency response. Interview questions focused on deficiencies in the local transportation system and ideas to address deficiencies. All interviews were conducted in person at locations in Bingen or White Salmon on April 5 and April 6, 2017. Interview participants included managers from Underwood Fruit, Mountain Logging/DJ's Repair and Rental, Dickey Farms, Rapid Ready Mix/Riley Materials, Bridge Mart, Bingen-White Salmon Police Department, Insitu, and a community member (individual). The interview responses mainly focused on identifying transportation challenges and possible solutions, identifying critical pathways for emergency responders, congestion issues, and safety issues on SR-14. Below are a few of the important points noted from the stakeholder interview responses.

- Traffic on SR-14 is “constant” with increasing congestion compared to the past
- There are too many heavy trucks on SR-14 that should be on I-84
- Improvements may be needed in town to enhance flow

- Many businesses rely on SR-14 for truck deliveries
- Congestion is affecting truck flows and shipments as well as worker commute times
- Turn lanes on SR-14 would help trucks access businesses
- Safety is an issue for vehicles trying to turn onto SR-14 and pedestrians crossing SR-14 during heavy traffic periods

Detailed stakeholder interview notes are included in Appendix B.

In addition to the stakeholder interviews, three Advisory Committee meetings were held in Bingen in June, September, and November 2017. The Advisory Committee consists of representatives from Southwest Washington RTC, WSDOT Southwest Region, City of Bingen, City of White Salmon, Klickitat County, and Port of Klickitat. The existing and future conditions transportation analysis findings and potential improvements have been presented to the committee. Valuable feedback received from Advisory Committee members was considered in the development of this memorandum. Key points raised in Advisory Committee meetings include:

- Volumes on SR-14 are higher in the summer months
- There is increasingly greater congestion compared to the past
- There are more trucks diverting from I-84 to SR-14
- Safety is an issue for pedestrians crossing SR-14 especially due to high truck volumes
- Rectangular Rapid Flashing beacons would help pedestrians to cross SR-14 safely at Walnut Street and Ash Street
- The City of Bingen could see a rapid expansion in the next 5-10 years in terms of business growth at the Port of Klickitat and/or private properties

4 EXISTING CONDITIONS

4.1 TRUCKS

Due to the presence of various private industrial and commercial freight truck related businesses, there is significant freight truck movement within the study area. Approximately 800 to 1,300 trucks travel on SR-14 daily (eastbound and westbound combined based on 2016 traffic counts), comprising 10-20% of total traffic on or to/from SR-14. Agricultural products, wood products, gravel, and waste scrap are the top commodities flowing into and out of Klickitat County, although commodity flows in and out of the study area could be somewhat different than the county as a whole. It is estimated that about 3-5% of truck traffic on I-84 in Oregon may be diverting to SR-14 to avoid the Oregon weight mile tax.

See Appendix A for a broad assessment of truck movements and commodity flows on SR-14.

4.2 TRAINS

The BNSF Railway corridor runs through the study area; this section of rail is within BNSF's Fallbridge Division. The rail corridor serves both freight and passenger trains. There are two Amtrak arrivals daily and about 35-39 freight trains per day. Many of these freight trains carry crude oil originating in North Dakota and bound for refineries in the Puget Sound area (Sightline Institute 2017; Washington State Department of Ecology 2018). Based on observations, trains traveling through the Bingen area typically

operate at an average speed of 30-35 mph with roadway blockage times (sampled at the Maple Street rail crossing) in the range of 2.0-3.5 minutes. Trains that pull onto rail sidings in Bingen would slow to operate through switches and stop to couple/uncouple cars. These locally destined trains block roadways for longer periods of times and often exceed 4 minutes of delay for vehicles stopped at rail crossings.

4.3 SAFETY

WSDOT provided crash data for crashes occurring from January 1, 2012 through November 30, 2016¹ for the portion of the SR-14 corridor within the study area (between mileposts (MP) 63.50 and 67.50). The crash data included information about crash severity, type, and contributing factors.

Between 2012 and 2016, there were 57 crashes on SR-14 within the study area. Of the total crashes, 15 of these crashes were injury crashes. There were no fatalities reported during this period. Table 2 includes the crash summary by severity on SR-14 for the years 2012 through 2016.

The corresponding crash rate for SR-14 in the study area is 89 crashes per 100 million vehicle miles of travel (VMT). The collision rate for Klickitat County for all roads in 2015 was 129.3 crashes per 100 million VMT (WSDOT 2015); thus, SR-14 in the study area is lower than the crash rate for the county.

Table 2. Crashes by Severity (2012-2016)

Year	Severity of Crash			Total Crashes
	Fatal	Injury	Other*	
2012	0	2	6	8
2013	0	2	8	10
2014	0	5	9	14
2015	0	4	10	14
2016	0	2	9	11
Total	0	15	42	57

*Other includes property damage only and/or crashes that did not cause any injuries

Source: WSDOT 2017.

The primary contributing factors to crashes on SR-14 in 2012-2016 were failure to yield, following too closely, and fatigue/inattention. Rear-end crashes comprise the predominant type of crashes at intersections accounting for 20 crashes. The high occurrence of rear-end crashes is likely related to congestion levels and driver behavior factors such as following too closely, driving too fast for safe operating conditions, or sudden stops for pedestrian crossings or parking movements. Table 3 summarizes crashes by type on SR-14 for the years 2012 through 2016.

¹ At the time of the data request, crash data was available only thru November 2016.

Table 3. Crashes by Type (2012-2016)

Crash Type	Number of Crashes
Overtuned	2
Sideswipe	2
Angle	7
Rear End	20
Vehicle Strikes Deer	7
Ditch	4
Rock/Rock Bank/Ledge	10
Other	5
TOTAL	57

Source: WSDOT 2017.

4.4 PUBLIC TRANSIT

Mt. Adams Transportation Services (MATS) intercity bus route connects the cities of Bingen and White Salmon with the city of Hood River. In 2018, MATS recently increased service on this fixed route, operating 10 times per day Monday through Friday (previously 4 times per day on Mondays, Wednesdays, and Fridays); these vehicles provide bicycle racks. MATS also operates a dial-a-ride service and a paratransit service line in the study area (Gorge Translink 2018). No other transit serves the study area.

4.5 PEDESTRIAN FACILITIES

Sidewalks are present on both sides along the SR-14 from about 0.30 miles west of Walnut Street to Maple Street. SR-14 also has sidewalks along the north side of the roadway east of Maple Street and on the south side between Dock Grade Road and about 0.30 miles west of Walnut Street. Some sidewalks are also present on both sides of Ash Street, Oak Street, and Maple Street within the study area. SR-141 Alt, Dock Grade Road and Hood River Bridge do not have sidewalks in the study area.

Within the study area, SR-14 has one signalized intersection at the Hood River Bridge with a single marked crosswalk on the south leg. All the legs at the Walnut Street, Ash Street and Oak Street intersections with SR-14 in downtown Bingen have marked crosswalks. However, only the north, south and west legs at the Maple Street intersection have marked crosswalks. There are no marked crosswalks at the SR-141 and Dock Grade Road intersections with SR-14.

4.6 BICYCLE FACILITIES

There are no designated bicycle facilities in the study area. However, the roadway shoulders along SR-14 between the Hood River Bridge and Willow Street have sufficient space to accommodate bicycles.

4.7 PARKING

The parking supply within the study area consists of angle and parallel on-street stalls as well as off-street parking spaces in private and public lots. Based on utilization estimates from parking counts performed, adequate on-street parking is available on SR-14 in the downtown Bingen area, from Willow Street to Cherry Street. As shown Figure 2, vehicle parking data on SR-14 (collected by the City of Bingen on April 20, 21, and 25 and July 26, 2017) shows utilization rates ranging from 30% to a high of 57% during peak summer months.

Figure 2. On-Street Parking Utilization in Bingen

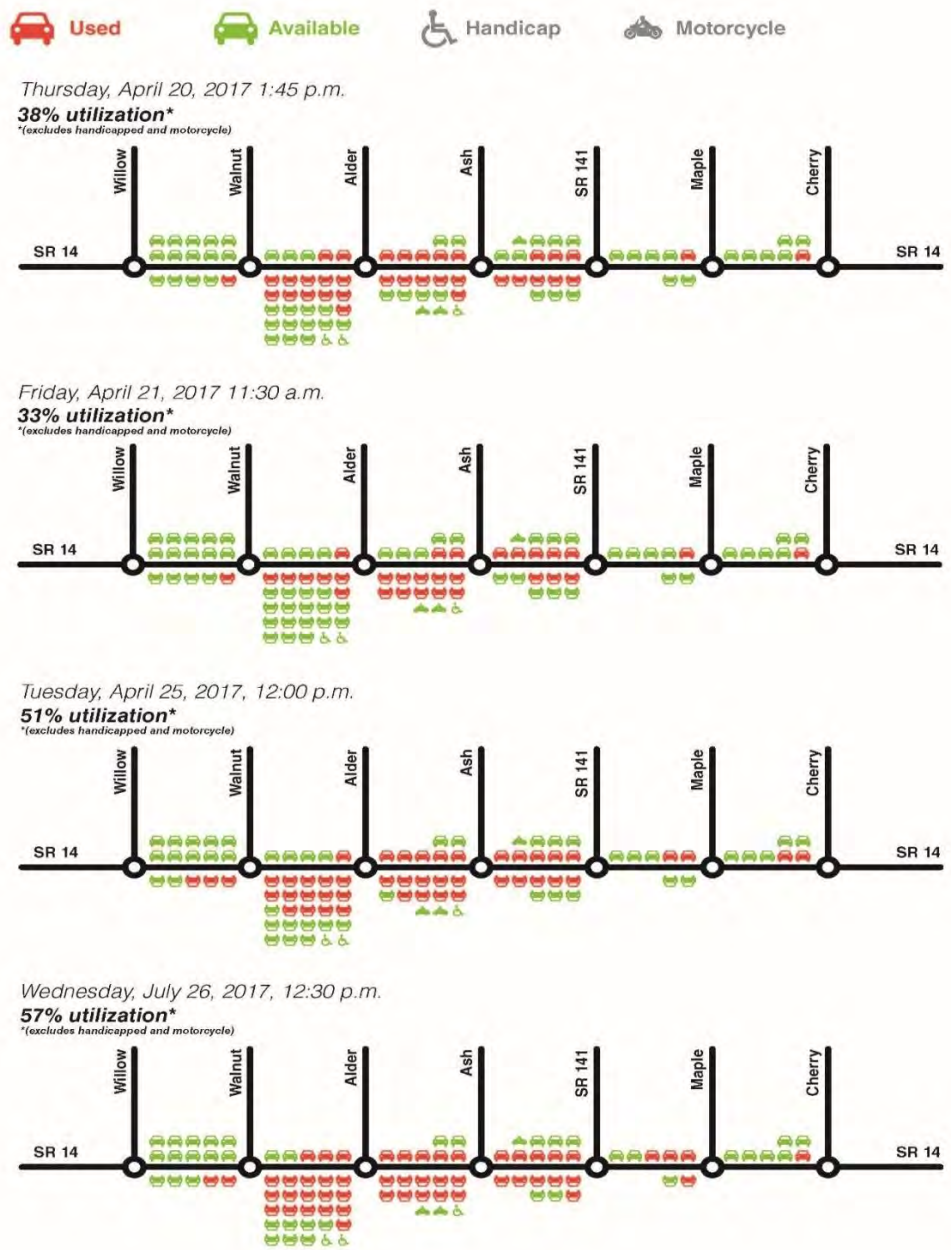

Source: City of Bingen 2017.

4.8 24-HOUR TRAFFIC COUNTS

The 24-hour tube counts were provided by RTC and collected in the study area from October 4 through October 6, 2016 (Tuesday-Thursday). These counts collected hourly traffic volumes and vehicle classifications on SR-14. West of SR-141 Alt, SR-14 carries approximately 5,890 vehicles per day; east of SR-141 Alt., SR-14 carries approximately 7,550 vehicles per day. West of Walnut Street SR-14 carries approximately 10,350 vehicles per day. SR-14 between Walnut Street and Alder Street carries approximately 10,280 vehicles in a day and east of the city limits it carries approximately 5,040 vehicles in a day.

The weekday hourly traffic volume data (shown in Figure 3 through Figure 7 and listed in Table 4) indicates that the study area experiences peak traffic volumes between approximately 7:00 am and 8:00 am and between 3:00 pm and 5:00 pm. Peaking around noon was also observed representing lunchtime activity.

A full week of additional traffic volume data was collected in the study area from July 25 through July 31, 2017, to supplement the data collected in October 2016. The 24-hour tube counts collected in October 2016 and in July 2017 were compared. For most segments, an average increase in demand of approximately 12% was noted for summer 2017 average daily traffic (ADT) volumes compared to those for fall 2016. Likewise, a comparison of summer and fall peak hour turn volumes at each study intersection found an average increase in summer peak hour turn volumes of 6% to 7%. Based on this summer and fall comparison, a 6% upward adjustment in demand was considered reasonable to be applied to the October 2016 counts.

Raw (native) traffic data is included in Appendix C.

Figure 3. 24-Hour Traffic Count Data for SR-14 west of SR-141 Alt (October 2016)

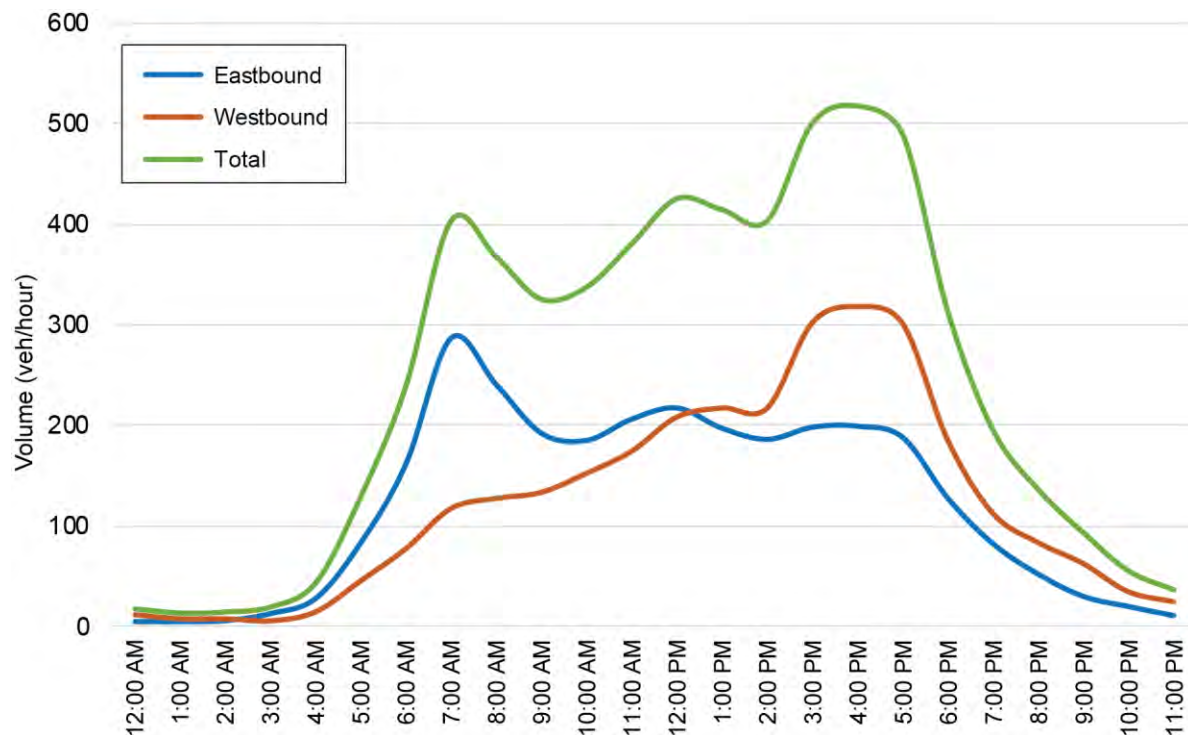

Figure 4. 24-Hour Traffic Count Data for SR-14 east of SR-141 Alt (October 2016)

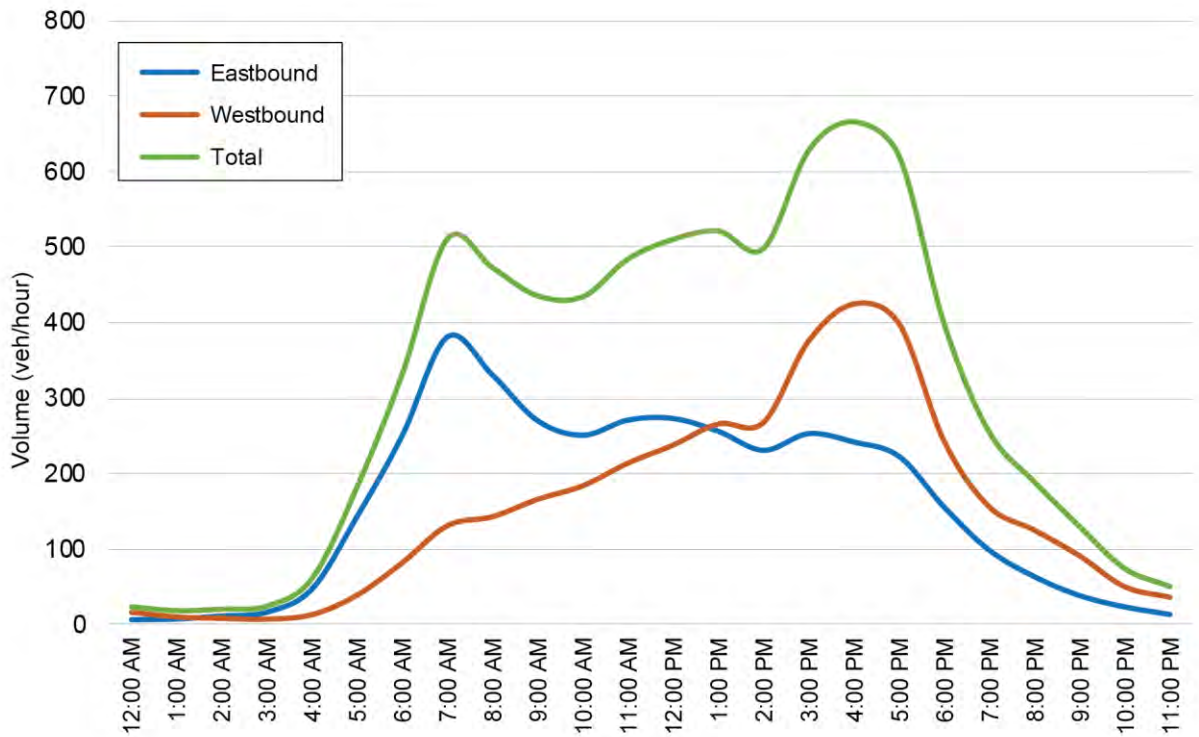

Figure 5. 24-Hour Traffic Count Data for SR-14 west of Walnut Street (October 2016)

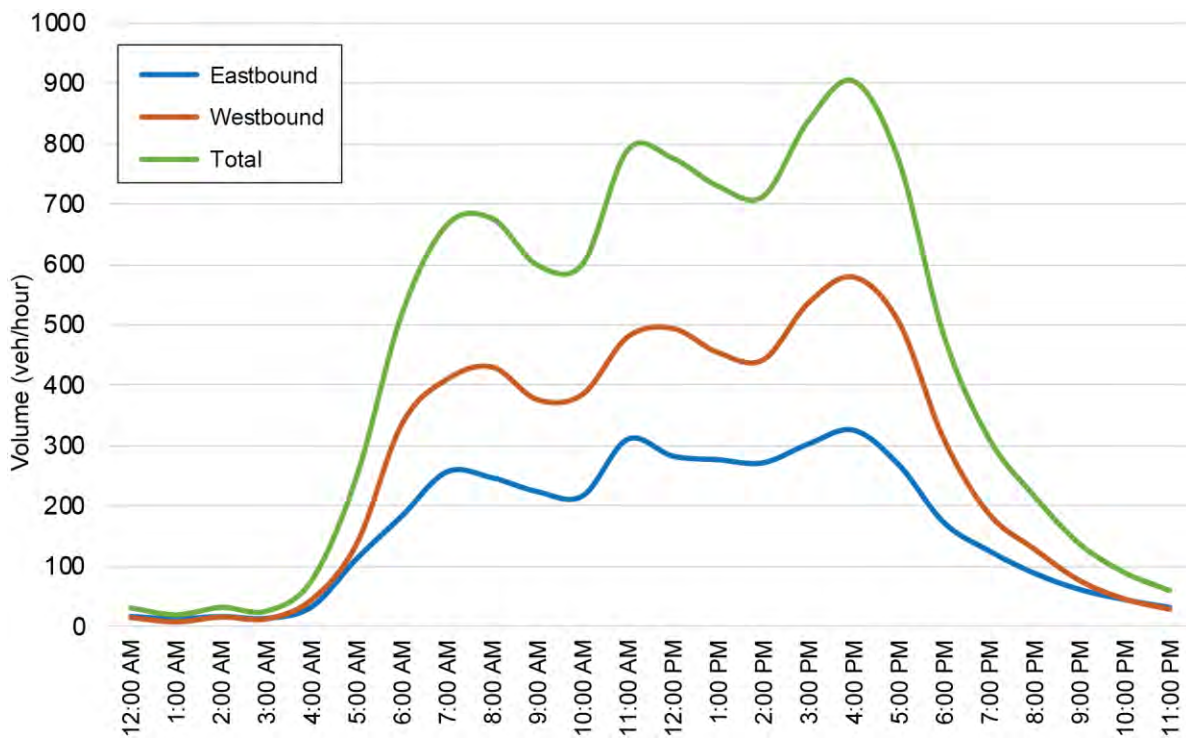

Figure 6. 24-Hour Traffic Count Data for SR-14 between Walnut Street and Alder Street (October 2016)

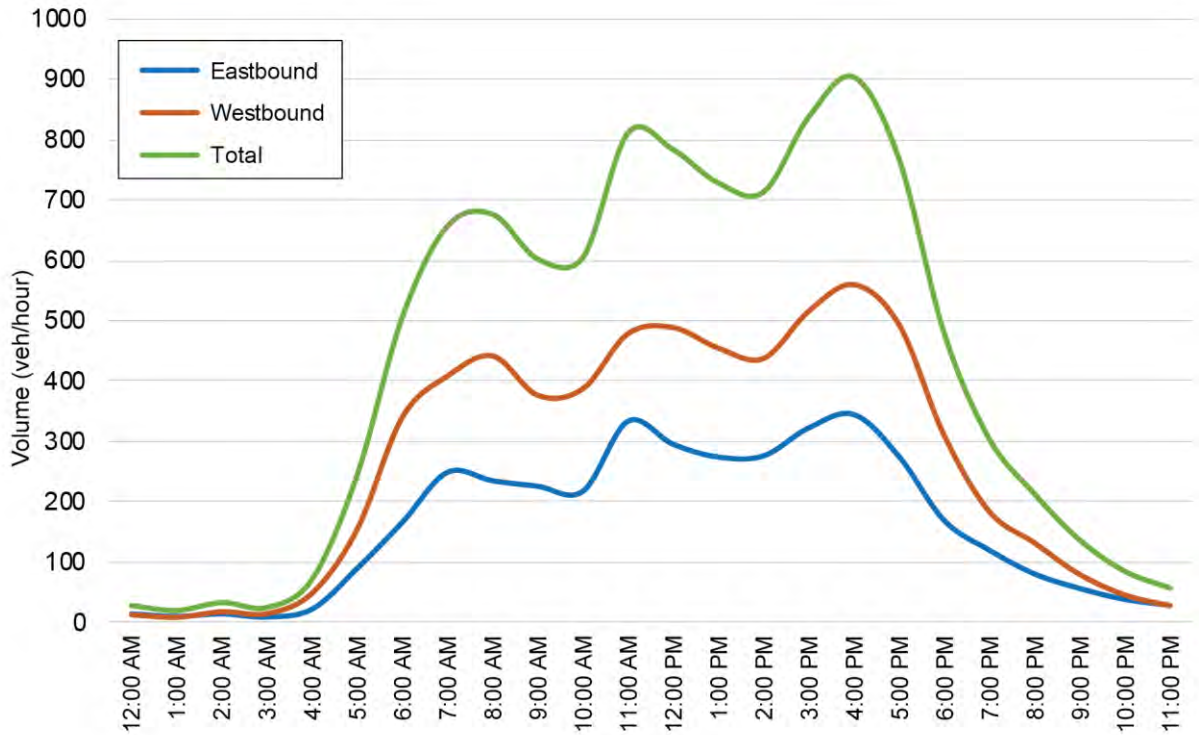

Figure 7. 24-Hour Traffic Count Data for SR-14 east of Bingen City Limits (October 2016)

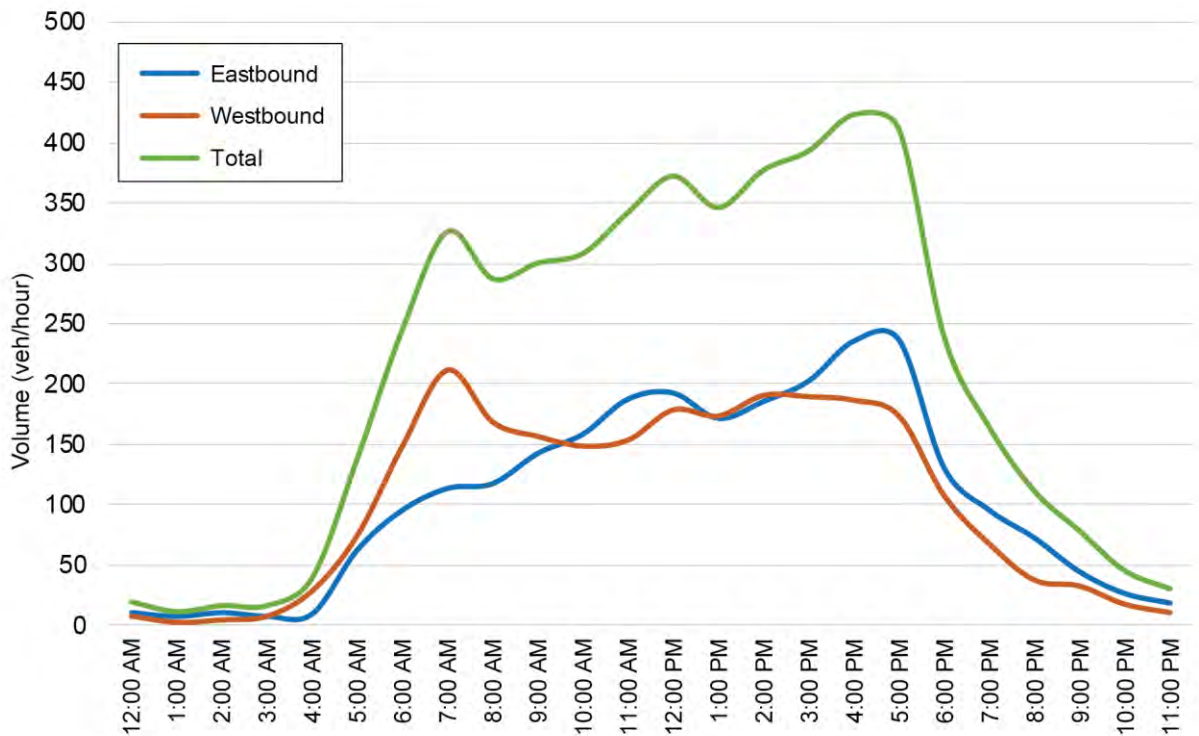

Table 4. 24-Hour Traffic Count Data (October 2016)

Location and Direction	Average Weekday Hourly Traffic																							TOTAL	
	12:00 AM	1:00 AM	2:00 AM	3:00 AM	4:00 AM	5:00 AM	6:00 AM	7:00 AM	8:00 AM	9:00 AM	10:00 AM	11:00 AM	12:00 PM	1:00 PM	2:00 PM	3:00 PM	4:00 PM	5:00 PM	6:00 PM	7:00 PM	8:00 PM	9:00 PM	10:00 PM		11:00 PM
SR-14 West of SR-141 Alt																									
Eastbound	6	6	7	14	29	84	162	286	240	192	185	206	217	197	186	198	199	188	128	83	53	31	21	12	2,930
Westbound	12	8	8	6	15	46	78	118	128	134	153	175	209	218	218	303	319	302	186	113	84	63	35	25	2,956
TOTAL	18	14	15	20	44	130	240	404	368	326	338	381	426	415	404	501	518	490	314	196	137	94	56	37	5,886
SR-14 East of SR-141 Alt																									
Eastbound	6	7	11	16	47	143	250	380	329	269	250	270	272	255	230	252	241	222	155	98	63	38	23	13	3,840
Westbound	17	11	9	8	14	40	83	132	144	167	185	215	239	267	269	377	426	400	244	157	126	92	51	37	3,710
TOTAL	23	18	20	24	61	183	333	512	473	436	435	485	511	522	499	629	667	622	399	255	189	130	74	50	7,550
SR-14 West of Walnut St.																									
Eastbound	16	12	16	13	32	112	183	256	246	223	216	310	282	276	271	302	325	268	172	125	88	61	44	31	3,880
Westbound	16	9	17	14	46	139	337	411	431	377	386	481	495	455	443	537	580	506	312	188	130	78	47	30	6,465
TOTAL	32	21	33	27	78	251	520	667	677	600	602	791	777	731	714	839	905	774	484	313	218	139	91	61	10,345
SR-14 Between Walnut St. and Alder St.																									
Eastbound	16	12	16	11	24	91	167	249	235	226	218	333	295	274	276	322	344	275	170	121	82	58	40	30	3,885
Westbound	12	8	17	14	48	154	339	407	440	375	386	477	487	453	436	514	558	492	309	183	131	79	45	27	6,391
TOTAL	28	20	33	25	72	245	506	656	675	601	604	810	782	727	712	836	902	767	479	304	213	137	85	57	10,276
SR-14 East of City Limits																									
Eastbound	11	8	11	8	10	63	96	114	118	143	159	188	193	172	186	203	236	237	131	96	73	45	27	19	2,547
Westbound	8	3	5	8	29	75	149	212	169	157	149	154	179	174	191	190	187	174	108	68	38	33	18	11	2,489
TOTAL	19	11	16	16	39	138	245	326	287	300	308	342	372	346	377	393	423	411	239	164	111	78	45	30	5,036

4.9 ORIGIN-DESTINATION DATA

Origin-destination (O-D) data was obtained using a Bluetooth-based collection process for 21 days from October 10 through October 30, 2016. Bluetooth readers capture unique identifiers from passing Bluetooth devices (vehicles, cell phones, etc.) and match these identifiers with those captured by Bluetooth readers in other locations to build an understanding of the origin from which vehicles are coming and the destination to which they are going. Seven Bluetooth readers were set up at the locations shown in Figure 8. The average daily count (October 2016) and percentage of trips from each origin to various destinations is shown in Table 5; graphical depictions of the trips are shown in Figure 9.

The O-D data helps form an understanding of the circulation on SR-14. For example, high volume turning movements along SR-14 can be identified along with an understanding of the route being taken to reach a certain destination, such as:

- **Left turns from southbound SR-141 Alt onto eastbound SR-14:** 479 of the total 575 trips (83%) turn left to travel east of this intersection with 307 trips (53%) destined for the Hood River Bridge.
- **Right turns from southbound SR-141 (Oak Street) to westbound SR-14:** 1,241 of the total 1,759 trips (70%) turn right to travel west of this intersection with 906 trips (51%) destined for the Hood River Bridge.
- **Left turns on northbound Maple Street onto westbound SR-14:** 325 of the total 412 trips (79%) turn left with 91 trips (22%) turning north on SR-141 and 181 trips (44%) traveling further west on SR-14 to the Hood River Bridge.

The O-D data indicates the highest single destination point for trips in the study area is the Hood River Bridge (and points south of the bridge). From origins within the study area, 32%-53% of the traffic is destined to the Hood River Bridge and totals 3,011 daily trips from various origins along SR-14. Conversely, northbound trips from the bridge to SR-14 number 3,284 per day with the highest percentage (33%) of those trips destined for Dock Grade Road.

The O-D data shows a clockwise rotation of trips traveling north from the Hood River Bridge on Dock Grade Road to White Salmon and south from White Salmon on SR-141 to the Hood River Bridge. This travel pattern occurs because SR-14 to Dock Grade Road is the shortest route into White Salmon from the Hood River Bridge. However, Dock Grade Road is a one-way road (northbound only), so traffic leaving White Salmon uses SR-141 (Oak Street) to SR-14 to access the Hood River Bridge.

O-D data also indicates that approximately 45% of the total 1,569 trips entering the study area west of SR-141 Alt will pass through the study area to a destination east of Bingen, while only approximately 32% of the total 1,624 trips entering the study area east of Bingen will pass through the study area to a destination west of the study area.

Figure 8. Origin-Destination Bluetooth Reader Locations

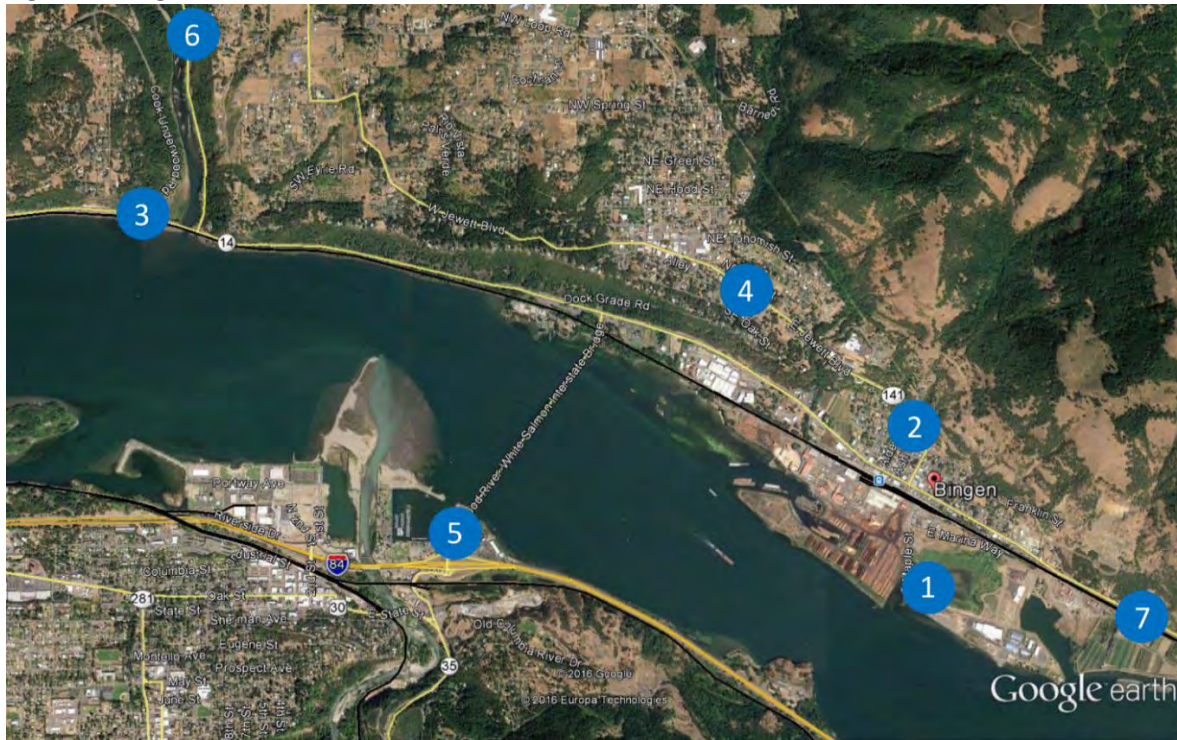
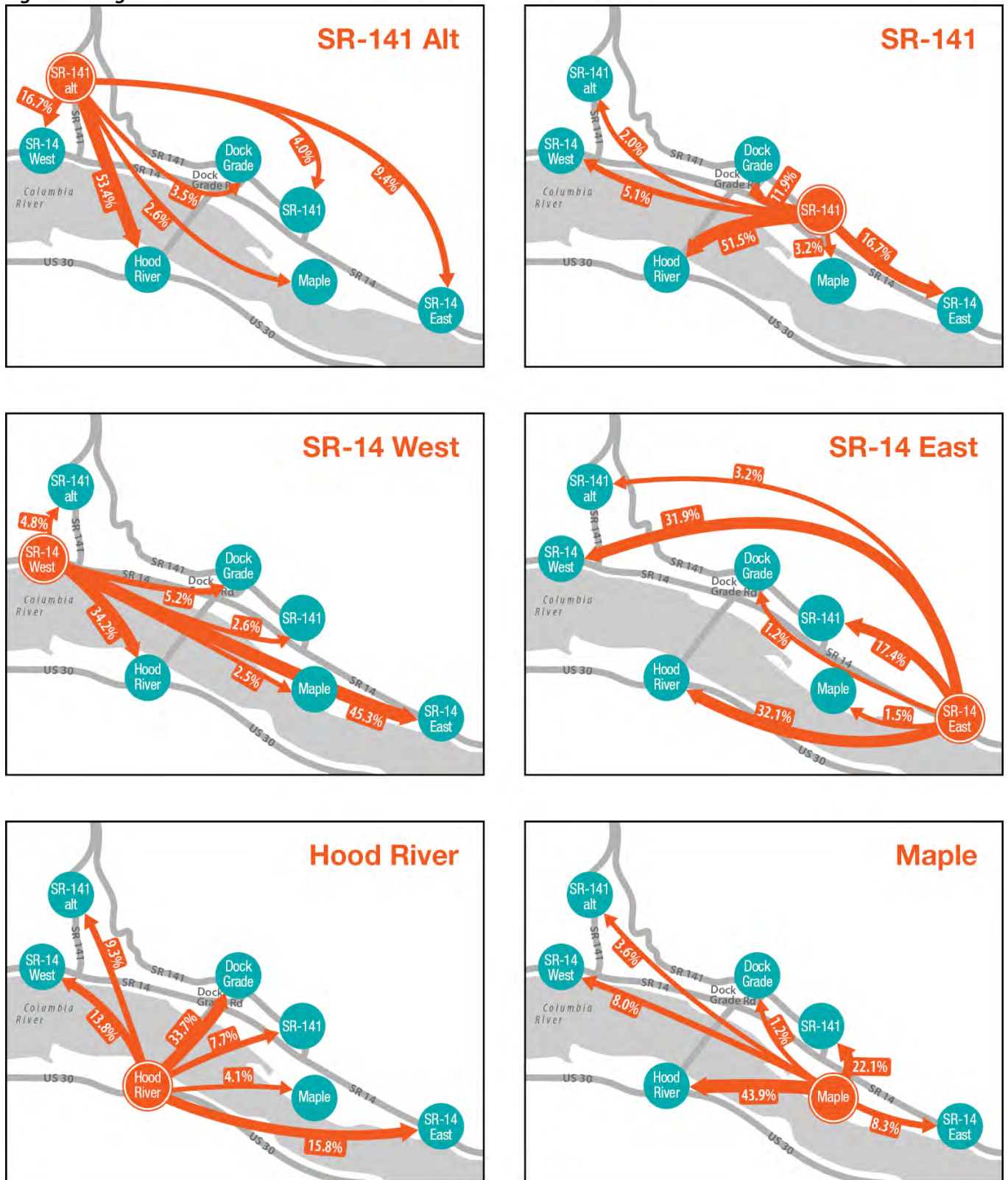

Table 5. Origin-Destination Average Daily Counts and Percentages (October 2016)

Map # / Origin		Map # / Destination							Total
		1	2	3	4	5	6	7	
		Maple St.	SR-141	West of SR-14	Dock Grade Rd.	HR Bridge	SR-141 Alt.	East SR-14	
1. Maple St.	Count	53	91	33	5	181	15	34	412
	%	12.9%	22.1%	8.0%	1.2%	43.9%	3.6%	8.3%	100%
2. SR-141	Count	57	168	89	210	906	36	293	1,759
	%	3.2%	9.6%	5.1%	11.9%	51.5%	2.0%	16.7%	100%
3. West SR-14	Count	39	41	85	81	537	75	711	1,569
	%	2.5%	2.6%	5.4%	5.2%	34.2%	4.8%	45.3%	100%
4. Dock Grade Rd.	Count	0	46	7	18	51	10	14	146
	%	0.0%	31.5%	4.8%	12.3%	34.9%	6.8%	9.6%	100%
5. Hood River Bridge	Count	136	254	454	1,107	507	306	520	3,284
	%	4.1%	7.7%	13.8%	33.7%	15.4%	9.3%	15.8%	100%
6. SR-141 Alt.	Count	15	23	96	20	307	60	54	575
	%	2.6%	4.0%	16.7%	3.5%	53.4%	10.4%	9.4%	100%
7. East SR-14	Count	25	283	518	19	522	52	205	1,624
	%	1.5%	17.4%	31.9%	1.2%	32.1%	3.2%	12.6%	100%
Total		325	906	1,282	1,460	3,011	554	1,831	9,369

Figure 9. Origin-Destination Patterns



4.10 INTERSECTION TRAFFIC COUNTS

Required traffic data for the analysis was provided by RTC, which included peak hour intersection traffic counts conducted in 2016 and 2017 to count turning and through movements. Signal phasing/timing data for the SR-14 and Hood River Bridge (SR-35) was provided by WSDOT.

Manual traffic counts were collected in October 2016 on Tuesday the 4th, Thursday the 6th and Saturday the 8th at for all study intersections except the SR-14 and Ash Street intersection which was collected in 2017 on Thursday, March 30th and Saturday, April 1st. Additional traffic count data was collected for all study intersections on Tuesday, July 18, 2017 to obtain traffic counts during the summer when volumes are typically higher². The traffic counts included passenger vehicles, trucks and bicycles making turning and through movements; counts of pedestrians crossing streets were also performed at the same time. For the purposes of the analysis, only the weekday (Tuesday and Thursday) counts were averaged during the PM peak hour to determine the weekday PM peak hour traffic volumes. On reviewing the weekday counts, the peak hour for the study area was determined to be from 4:05 pm to 5:05 pm.

The traffic volumes between intersections were then balanced and rounded³. Balancing the system peak hour volumes is necessary to ensure that the volume leaving an intersection and the volume arriving at the next intersection correctly reflects the level of access (traffic entering and leaving adjacent properties) likely to be occurring between the intersections. Volumes between intersections were accordingly balanced to account for driveways and roadways and rounded to determine the balanced existing year (2017) PM peak hour turn volumes. Vehicle classification for each study area intersection was determined from the existing turning movement counts.

The existing year (2017) PM peak hour traffic volumes are shown in Figure 10. Traffic data collected for the study is included in Appendix C.

² Traffic counts obtained during the summer represented an overall 12% increase in average daily traffic volumes compared to traffic counts conducted in the fall. Focusing on the PM peak hour, the intersection traffic volumes were 6%-7% higher in the summer than in the fall. Based on this analysis and consultation with RTC, a 6% upward adjustment to the October 2016 traffic counts was made to normalize all counts to represent 2017 summer conditions.

³ Balancing traffic counts is a standard practice to adjust volumes so there is consistency when aggregating links (or segments) in the traffic analysis model. The number of vehicles entering/exiting at one intersection and mixed with the mainline through and turning volumes as well as driveways are adjusted (usually minor adjustments) so that there is consistency with the number of vehicles modeled at the adjacent intersections. Volumes are typically rounded to 5s or 10s.

Figure 10. Existing Conditions Traffic Volumes during the PM Peak Hour (2017)

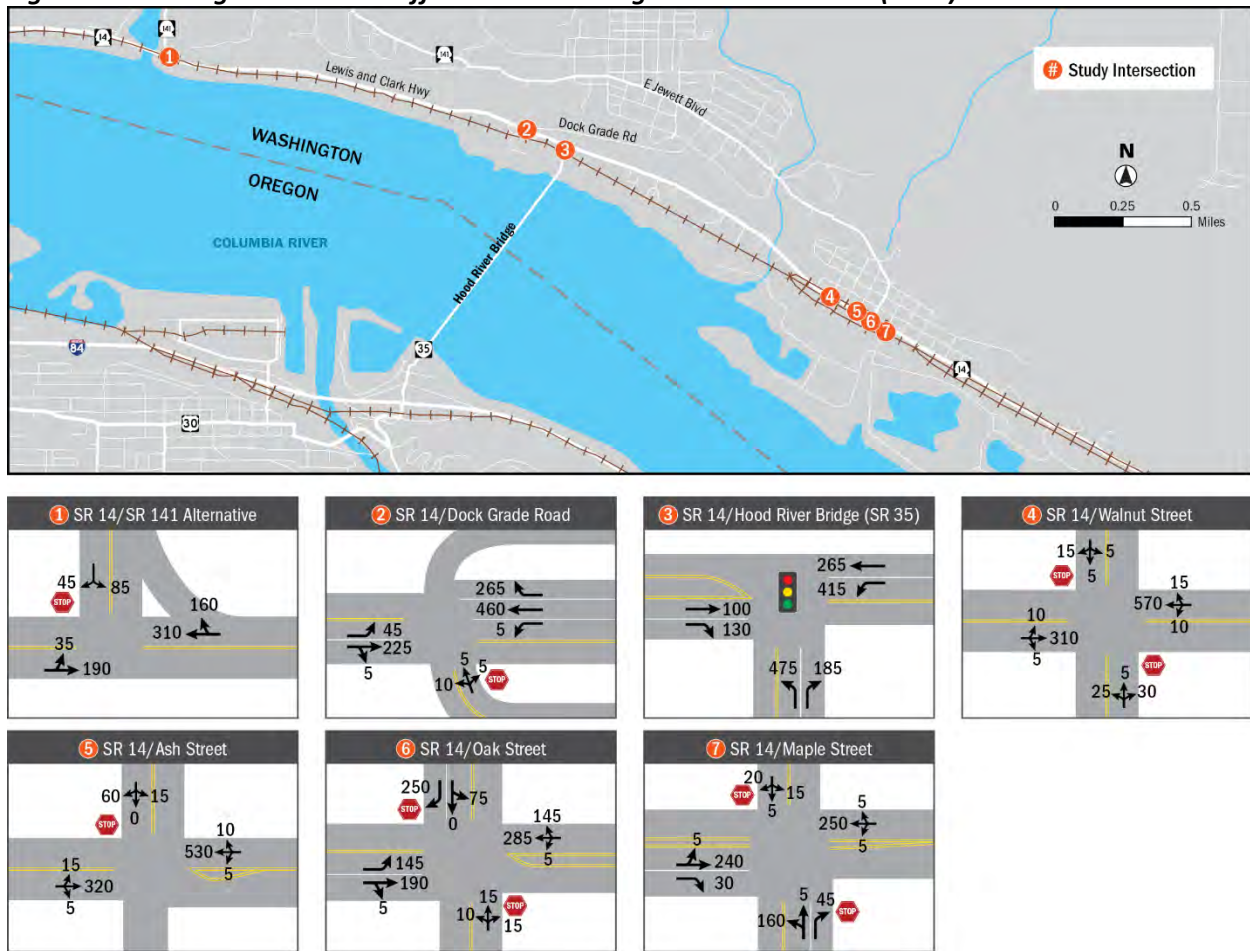

4.11 TRAFFIC OPERATIONAL ANALYSIS

Two analyses were used to characterize traffic operations in the study area:

- Highway Segment Levels of Service (LOS) to understand overall traffic flow on SR-14
- Intersection LOS to distill queuing and delays associated with each directional movement at key intersections along SR-14

4.11.1 Traffic Operations by Highway Segment

Within the study area, the SR-14 corridor was divided into four segments based on highway characteristics (rural or urban context), posted speed limits, and the density of driveways and intersecting roadways. The specific segments that were analyzed include:

- **Segment 1:** SR-141 Alternate to the Hood River Bridge access road
- **Segment 2:** Hood River Bridge access road to Walnut Street
- **Segment 3:** Walnut Street to Elm Street
- **Segment 4:** Elm Street to eastern Bingen

Table 6. Driving Conditions by Highway LOS

Level of Service	Description
A-C	Vehicles are traveling individually or beginning to be grouped in platoons, which provides gaps for vehicles on intersecting streets or in driveways to enter the highway.
D	Vehicle platooning increases and gaps between platoons decrease and highway speeds slow down.
E	The highway is nearing capacity, vehicles wanting to enter the highway have difficulty finding gaps.
F	The highway capacity has been exceeded and gridlock conditions occur.

Highway Level of Service (LOS) was used to describe existing and future projected SR-14 traffic conditions⁴. This Highway LOS measure provides a relative characterization of the level of congestion and associated flow conditions along the highway (Table 6). The Highway LOS was further categorized by a highway classification and an arterial classification.

- The **Highway LOS (highway classification)** was calculated for both westbound and eastbound directions based on the directional volume of traffic, average travel speed, and percent time spent by each vehicle following another vehicle, and the volume of traffic on the opposing direction that allows for passing opportunities. The highway classification was applied to Segments 1 and 4, which are have more rural characteristics.
- The **Highway LOS (arterial classification)** was calculated based on the estimated speed relative to the free flow (posted) speed for both westbound and eastbound directions. The arterial classification was applied to Segments 2 and 3, which have more urban characteristics.

WSDOT sets Highway LOS standards for peak hour on state highways of statewide significance, including SR-14 based on RCW 47.06.140(2). The peak hour performance standard set by WSDOT for Klickitat County is LOS C or better (WSDOT 2010). Performance standards are often used to measure and identify a condition that is acceptable (meets or exceeds the standard or better) or is not acceptable (performs below the standard). If performance is below the standard, then agencies with jurisdiction of the roadway may investigate options to make improvements so that operational performance increases.

Under the existing conditions, the SR-14 corridor meets the WSDOT⁵ Highway LOS C standard for all segments except the eastbound direction on Segment 1 (SR-141 Alt to Hood River Bridge) as illustrated in Figure 11. The eastbound traffic on Segment 1 experiences slightly more congestion because of traffic volume levels approaching the Hood River Bridge access road intersection, the traffic signal at that intersection that constrains traffic flow, and the higher opposing volume in the westbound direction that reduces passing opportunities for eastbound vehicles.

⁴ Highway Capacity Software (HCS7) was used, which implements the methodology for analyzing two-lane highways as prescribed in the Transportation Research Board Highway Capacity Manual 6th Edition, 2010.

⁵ Level of Service Standards for Washington State Highways, 2010.

Figure 11. SR-14 Highway Segment Levels of Service – Existing Conditions (2017)

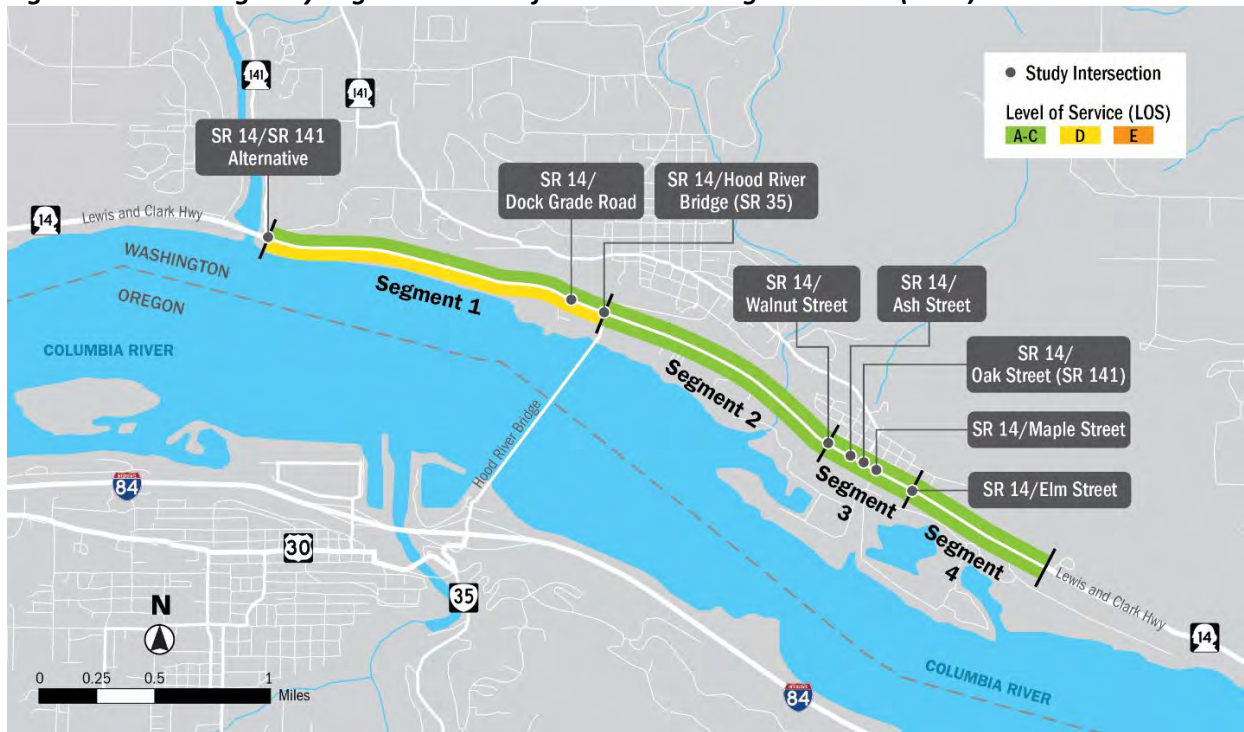

4.11.2 Intersection Operations

Synchro 9 software was used to perform the existing year (2017) and future year (2037) operations analysis for both highway and intersection LOS. Synchro calculates the Intersection Level of Service (LOS) based on the average vehicle delays for signalized intersections as prescribed in the Transportation Research Board’s Highway Capacity Manual (HCM) 2000. Thus, the HCM 2000 calculation was used to estimate average vehicle delays at the SR-14 and Hood River Bridge (SR-35) signalized intersection and assign the Intersection LOS values for each direction of travel as well as the overall intersection operations. As outlined in the HCM, LOS for signalized intersections is defined by the average vehicle delay for all movements measured in seconds per vehicle.

For unsignalized intersections, Synchro uses definitions in the HCM 2010, so the HCM 2010 calculation was used to estimate average vehicle delay and indicate the Intersection LOS at all unsignalized intersections.

The intersection analysis relied on Intersection LOS as the critical performance measure to identify where potential improvements would be needed to reduce congestion levels. The percentage of heavy vehicles, defined by the HCM as vehicles with more than four wheels touching the pavement during normal operation (buses, RVs, and trucks), was factored into the Synchro traffic operation modeling because these large vehicles can affect traffic operations differently than passenger vehicles. Larger vehicles are longer in length and typically take more time and distance to slow or come to a stop as well as accelerate from a stopped or slowed condition.

Table 7 summarizes the Intersection LOS criteria as described in the HCM 2000 (signalized intersections) and 2010 (unsignalized intersections).

Table 7. LOS Criteria for Intersections

Level of Service	Average Vehicle Delay (seconds/vehicle)		Description
	Signalized Intersection	Unsignalized Intersection	
A	≤ 10	0 – 10	Free Flow
B	> 10 - 20	> 10 – 15	Stable Flow (slight delays)
C	> 20 - 35	> 15 - 25	Stable Flow (acceptable delays)
D	> 35 - 55	> 25 – 35	Approaching unstable flow
E	> 55 - 80	> 35 - 50	Unstable Flow (intolerable delay)
F	> 80	> 50	Forced Flow (congested/fail to clear)

Source: Transportation Research Board Highway Capacity Manual, 2000 (signalized) and 2010 (unsignalized).

During existing year 2017, the average vehicle delay at all legs of all study area intersections in the PM peak hour fell within Intersection LOS A-C (free flow or stable flow conditions) except for:

- The SR-14/Hood River Bridge (SR-35) intersection westbound left turn lane (181.4 seconds per vehicle, LOS F), northbound left turn lane (70.8 seconds, LOS E), and northbound right turn lane (39.8 seconds, LOS D).
- The SR-14/Oak Street intersection northbound lane (31.2 seconds, LOS D) and southbound through/left turn lane (55.8 seconds, LOS F).

A summary of the average vehicle delay and Intersection LOS for existing year 2017 is provided in Table 8 and Figure 12. The Intersection LOS worksheets for existing conditions are included in Appendix D.

Table 8. Average Vehicle Delay: Existing Conditions during the PM Peak Hour (2017)

Intersection	Lane/Movement	PM Peak Hour	
		Delay (sec/veh)	LOS
1 SR-14 and SR-141 Alternative <i>(unsignalized)</i>	EB Through/Left Turn	8.1	A
	WB Through	0.0	A
	SB Left/Right Turn	16.1	C
2 SR-14 and Dock Grade Road <i>(unsignalized)</i>	NB Left/Through/Right	15.3	C
	EB Left Turn	8.6	A
	EB Through/Right Turn	0.0	A
	WB Left Turn	7.8	A
	WB Through	0.0	A
	WB Right Turn	0.0	A
3 SR-14 and Hood River Bridge (SR-35) <i>(signalized)</i>	EB Through	32.6	C
	EB Right Turn	5.7	A
	WB Left	181.4	F
	WB Through	13.9	B
	NB Left Turn	70.8	E
	NB Right Turn	39.8	D
4 SR-14 and Walnut Street <i>(unsignalized)</i>	NB Left/Through/Right	24.7	C
	EB Left/Through/Right	8.9	A
	WB Left/Through/Right	8.2	A
	SB Left/Through/Right	19.4	C
5 SR-14 and Ash Street <i>(unsignalized)</i>	EB Left/Through/Right	9.0	A
	WB Left/Through/Right	8.0	A
	SB Left/Through/Right	17.0	C
6 SR-14 and Oak Street (SR-141) <i>(unsignalized)</i>	NB Left/Through/Right	31.2	D
	EB Left Turn	9.1	A
	EB Through/Right Turn	0.0	A
	WB Left/Through/Right	7.7	A
	SB Through/Left Turn	55.8	F
	SB Right Turn	15.7	C

Intersection	Lane/Movement	PM Peak Hour	
		Delay (sec/veh)	LOS
7 SR-14 and Maple Street (unsignalized)	NB Through/Left	22.6	C
	NB Right Turn	10.1	B
	EB Through/Left	7.8	A
	EB Right Turn	0.0	A
	WB Left/Through/Right	8.0	A
	SB Left/Through/Right	12.8	B

NB = northbound; SB = southbound; WB = westbound; EB = eastbound

Color coding: LOS A-C (green); LOS D (yellow); LOS E (orange); LOS F with delay less than 300 seconds (red); LOS F with delay more than 300 seconds (black)

Figure 12. Existing Conditions Intersection Levels of Service during the PM Peak Hour (2017)

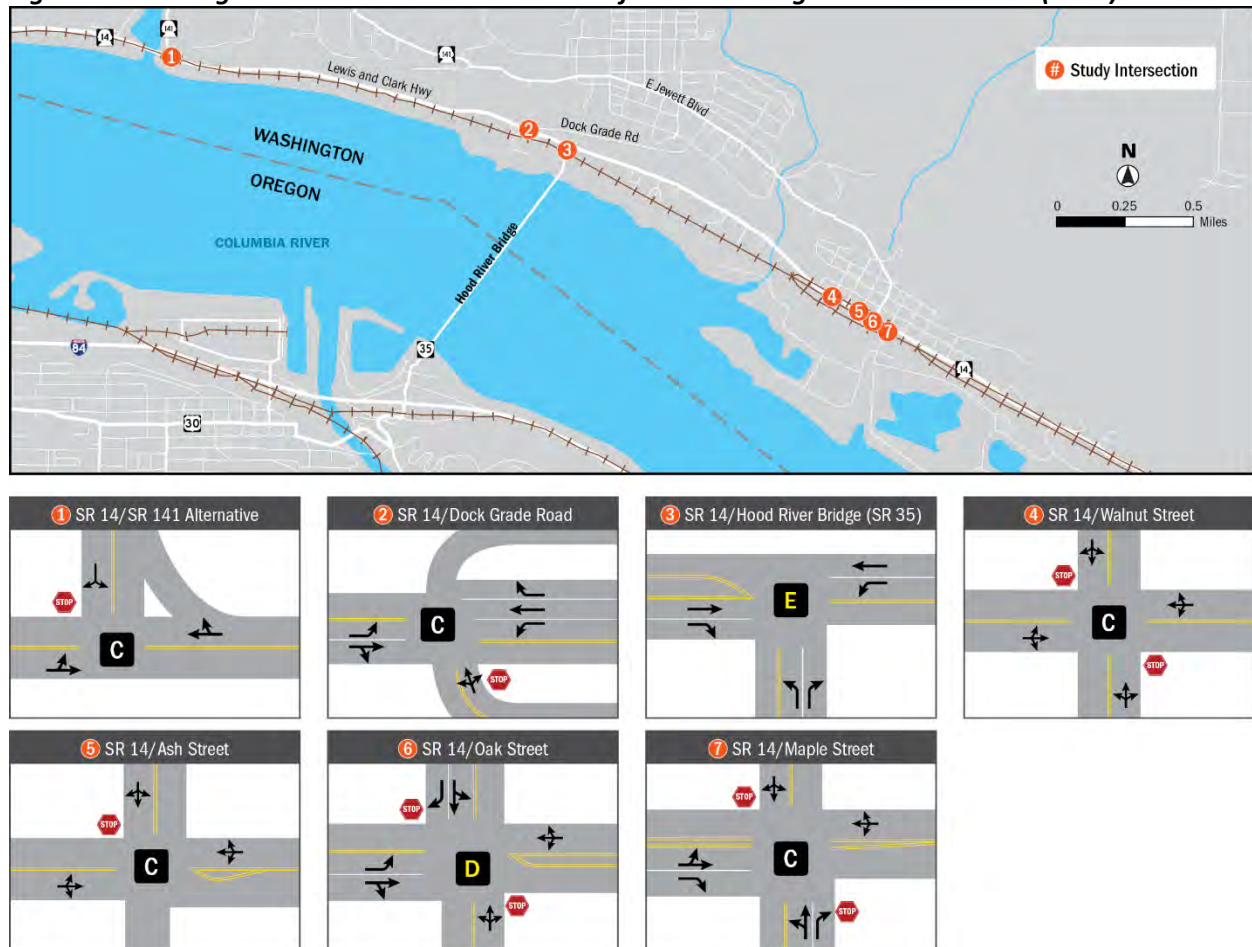

5 FUTURE YEAR ASSUMPTIONS

The analysis of future traffic conditions for all alternatives considered in this study was based on a 20-year outlook with 2037 as the target horizon year; thus, all future year conditions represent projected conditions in the year 2037.

At the time of this study, there were no traffic growth rates and/or travel demand models available for the study area; therefore, average daily traffic (ADT) volumes from WSDOT's Annual Traffic Reports were used (WSDOT 2016). An analysis of these ADT volumes for the years 2006 through 2016 found significant variation in traffic volumes between years. Some years had significant increases in traffic and other years had significant decreases, the variation was likely due to economic influences. Absent a consistent historical year-over-year growth rate, the average WSDOT ADT volume for the years 2006 through 2016 was calculated, resulting in a projected annual growth rate of 3% for peak period traffic volumes on SR-14. This average was assumed for the years 2018 through 2025. However, a growth rate of 1.5% was assumed for the years 2026 through 2037 to reflect flattening of the long-range growth curve. For side streets, a 1.5% annual growth was assumed from 2017 to 2037. The 1.5% annual growth rate is consistent with the Washington State Office of Financial Management's (OFM) November 2016 long-range statewide and regional population forecasts. The cumulative traffic growth over the next 20 years would represent approximately a 52% increase in traffic volumes by year 2037; the average annual growth rate would be approximately 2.1%.

Approximately 60 acres of undeveloped property zoned for industrial use is located south of the BNSF Railway main line and between the entrance to Bingen Harbor (east) and South Maple Street (west). Of this total, 30 acres are within the Port of Klickitat Bingen Point Business Park, 5 acres are immediately adjacent to the business park along the Columbia River, and 25 acres are immediately north of Bingen Harbor. For the purposes of this study, it was assumed that 60% (approximately 35 acres) would be developed by the target horizon year (2037) and a slightly lower factor⁶ (50%) would be used to represent the future number of employees and traffic volumes from this industrial land by year 2037.

6 FUTURE NO BUILD CONDITIONS

The Future No Build represents conditions that would occur in 2037 if no roadway improvements are implemented in the study area.

6.1 TRAFFIC VOLUMES

Modeling of the Future No Build conditions assumes the same lane configurations as those shown in the Existing Conditions section (Section 4) of this report. The modeling projects that cumulative traffic growth over the next 20 years would result in a 52% increase in traffic volumes by 2037. Figure 13 illustrates the PM peak hour traffic volumes for the seven study area intersections projected to occur in 2037.

⁶ Coordination between RTC and the Port of Klickitat led to an assumption that current employee density (jobs per acre) may not be sustained in the future; thus, a downward adjustment was made to employee levels associated with future land development.

Figure 13. Future No Build Traffic Volumes during the PM Peak Hour (2037)

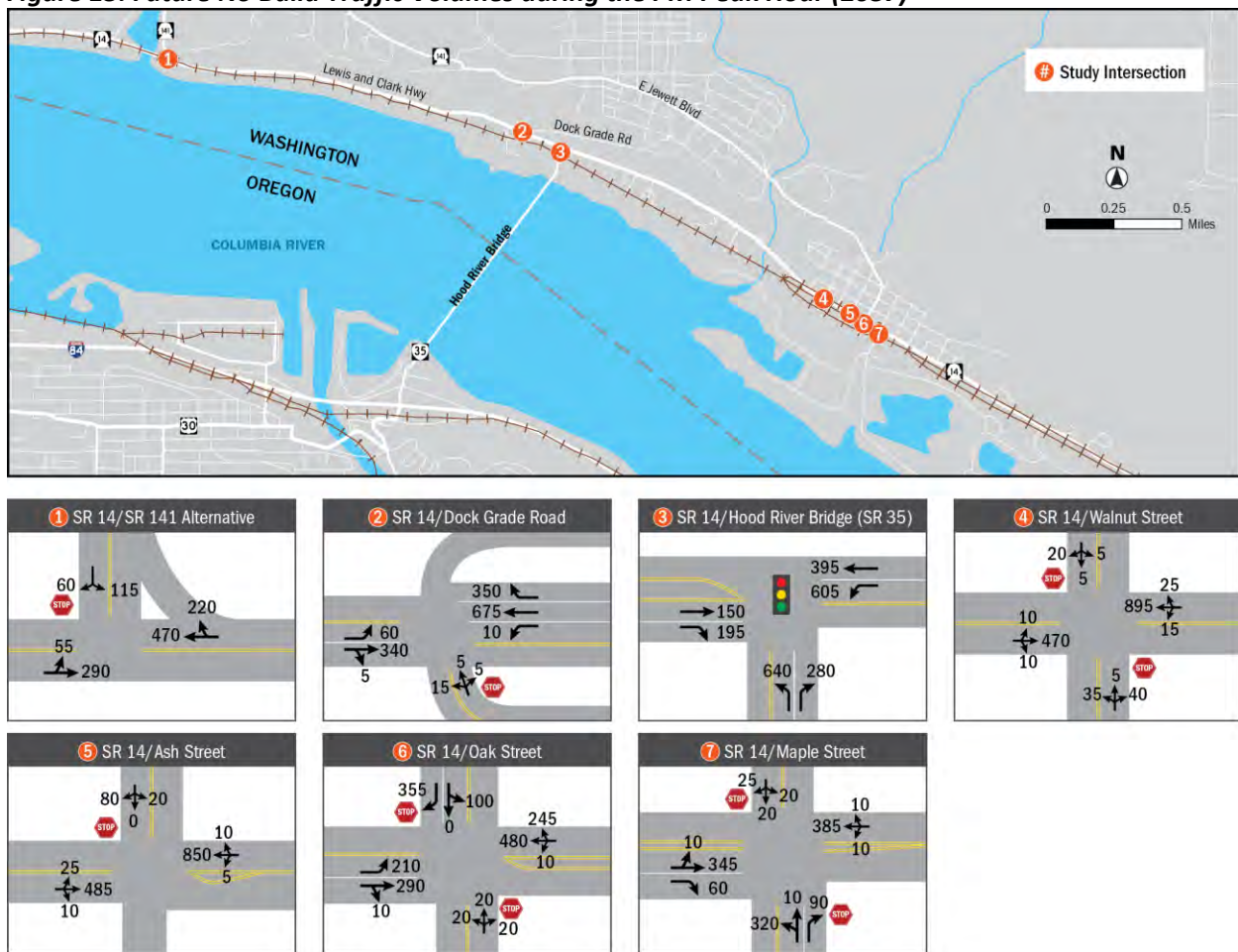

6.2 TRAFFIC OPERATIONAL ANALYSIS

6.2.1 Traffic Operations by Highway Segment

Without any improvements made in the study area, highway traffic operations on SR-14 would deteriorate from Highway LOS C to LOS D on three segmental directions and to LOS E on one segmental direction (Figure 14) compared to the existing conditions. Specifically:

- Westbound Elm Street to Walnut Street (Segment 3) in the core area of Bingen and the Hood River Bridge to SR-141 Alt. (Segment 1), which includes a high volume of traffic coming off the Hood River Bridge and turning onto Dock Grade Road, would experience increased congestion resulting in LOS D compared to LOS C under the existing conditions (2017).
- Eastbound traffic from the Hood River Bridge to Walnut Street (Segment 2) would be more congested for vehicles heading into Bingen resulting in LOS D and eastbound traffic on Segment 1 would remain at LOS D similar to existing conditions.

Figure 14. SR-14 Highway Segment Levels of Service – Future Conditions (2037)

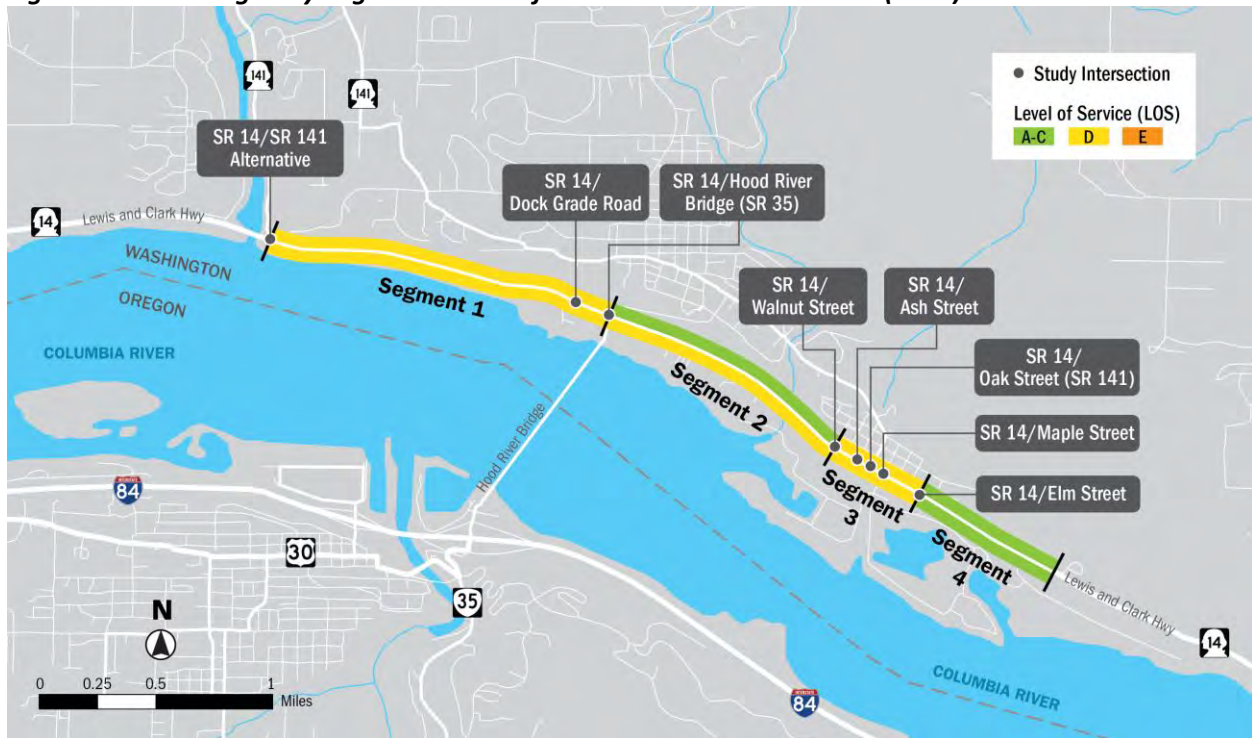

6.2.2 Intersection Operations

An increase in traffic volumes on SR-14 by 2037 would result in significant congestion in the study area. Based on the operational analysis, all study area intersections would experience significantly higher delays on one or more legs than they do in the existing conditions. Intersection legs with delays of greater than 3 minutes would occur when there are few to no gaps between vehicles traveling on SR-14 for the side street turning vehicles to enter. This is particularly difficult for through movements and left turns where gaps in both directions of SR-14 would be needed to complete the movement. Directional movements by intersection that would have average vehicle delays greater than 3 minutes include:

- **SR-14/Walnut Street:** The northbound lane would experience delays of 191.5 seconds per vehicle (LOS F).
- **SR-14/Oak Street:** The northbound lane and southbound through/left turn lane would experience delays of more than 300 seconds (LOS F).
- **SR-14/Maple Street:** The northbound through/left turn lane would experience delays of more than 300 seconds (LOS F).

A summary of the Future No Build average vehicle delays and Intersection LOS is provided in Table 9 and Figure 15. The Intersection LOS worksheets for Future No Build conditions are provided in Appendix D.

Table 9. Average Vehicle Delay: Future No Build Conditions during the PM Peak Hour Compared to Existing Conditions

Intersection		Lane/Movement	Existing (2017)		Future No Build (2037)	
			Delay (sec/veh)	LOS	Delay (sec/veh)	LOS
1	SR-14 and SR-141 Alternative <i>(unsignalized)</i>	EB Through/Left Turn	8.1	A	8.8	A
		WB Through	0.0	A	0.0	A
		SB Left/Right Turn	16.1	C	38.0	E
2	SR-14 and Dock Grade Road <i>(unsignalized)</i>	NB Left/Through/Right	15.3	C	26.9	D
		EB Left Turn	8.6	A	9.5	A
		EB Through/Right Turn	0.0	A	0.0	A
		WB Left Turn	7.8	A	8.1	A
		WB Through	0.0	A	0.0	A
		WB Right Turn	0.0	A	0.0	A
3	SR-14 and Hood River Bridge (SR-35)* <i>(signalized)</i>	EB Through	32.6	C	46.2	D
		EB Right Turn	5.7	A	10.3	B
		WB Left	181.4	F	126.7	F
		WB Through	13.9	B	14.8	B
		NB Left Turn	70.8	E	124.2	F
		NB Right Turn	39.8	D	6.5	A
4	SR-14 and Walnut Street <i>(unsignalized)</i>	NB Left/Through/Right	24.7	C	191.5	F
		EB Left/Through/Right	8.9	A	10.4	B
		WB Left/Through/Right	8.2	A	8.9	A
		SB Left/Through/Right	19.4	C	40.7	E
5	SR-14 and Ash Street <i>(unsignalized)</i>	EB Left/Through/Right	9.0	A	10.6	B
		WB Left/Through/Right	8.0	A	8.5	A
		SB Left/Through/Right	17.0	C	46.3	E
6	SR-14 and Oak Street (SR-141) <i>(unsignalized)</i>	NB Left/Through/Right	31.2	D	>300	F
		EB Left Turn	9.1	A	11.6	B
		EB Through/Right Turn	0.0	A	0.0	A
		WB Left/Through/Right	7.7	A	8.1	A
		SB Through/Left Turn	55.8	F	>300	F
		SB Right Turn	15.7	C	66.6	F

Intersection		Lane/Movement	Existing (2017)		Future No Build (2037)	
			Delay (sec/veh)	LOS	Delay (sec/veh)	LOS
7	SR-14 and Maple Street <i>(unsignalized)</i>	NB Through/Left	22.6	C	>300	F
		NB Right Turn	10.1	B	11.5	B
		EB Through/Left	7.8	A	8.3	A
		EB Right Turn	0.0	A	0.0	A
		WB Left/Through/Right	8.0	A	8.4	A
		SB Left/Through/Right	12.8	B	20.6	C

*Denotes signal modification to adjust timing for northbound to eastbound right turns and westbound to southbound left turns for all future year (2037) conditions.

NB = northbound; SB = southbound; WB = westbound; EB = eastbound

Color coding: LOS A-C (green); LOS D (yellow); LOS E (orange); LOS F with delay less than 300 seconds (red); LOS F with delay more than 300 seconds (black)

Figure 15. Future No Build Intersection Levels of Service during the PM Peak Hour (2037)

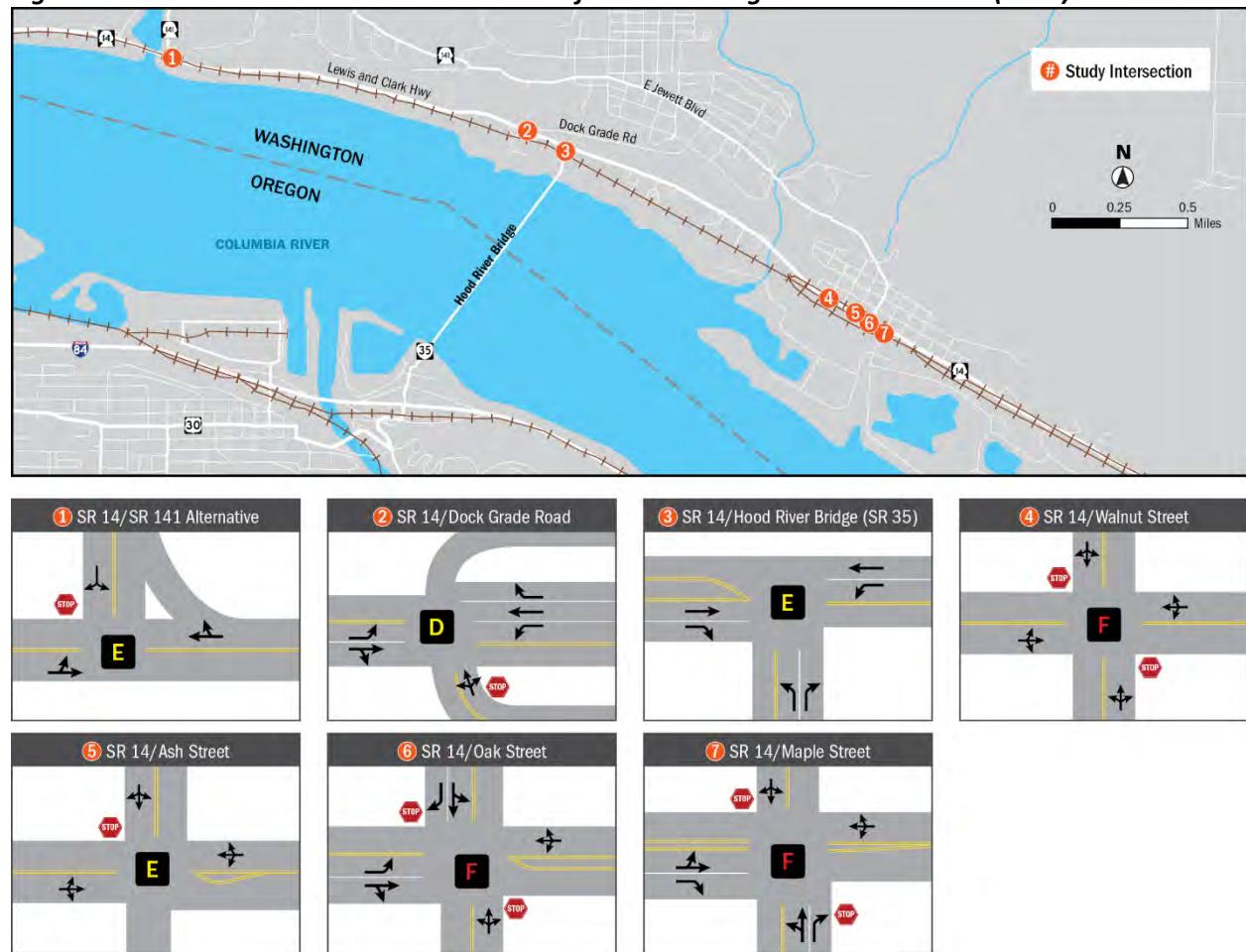

6.3 TRUCKS

The annual growth in the number of trucks (based on an assignment of the Federal Highway Administration (FHWA) Freight Analysis Framework (FAF) 4.2 commodity flows) during the study period is anticipated to be approximately 1.9%. This is slightly less than the average annual rate of traffic volume increases (approximately 2%), as discussed in Section 5. Thus, the proportion of trucks is expected to remain nearly the same but decline very slightly over time.

The total commodities transported in and out of Klickitat County by truck are expected to increase by more than 50% and exceed three million tons by 2045 based on commodity flow data provided by the FHWA's FAF 4.2 database. The county has six major ingress/egress routes (US 97 North, US 97 South (Biggs Bridge), US 197 South (The Dalles Bridge), SR-14 East, SR-14 West, and SR-35 South (Hood River Bridge)); only the SR-14 West and SR-35 South ingress/egress points are within the study area. The top five commodities originating from or destined to the county in terms of tonnage today include logs, other agricultural products, wood products, gravel and waste/scrap. Given the number of highways in Klickitat County, not all of these commodities would be transported on SR-14.

Appendix A provides additional detail regarding projected truck demands (volumes) and commodity flows.

6.4 TRAINS

The BNSF Railway (Fallbridge Division) corridor through the study area is expected to accommodate a significant increase in rail freight service in the future due to major downstream port terminal expansions and waterfront properties along the Columbia River in Longview and Vancouver, Washington as well as continued service to the Puget Sound. The anticipated increase in rail freight service would result in more frequent train movements and/or could involve use of longer trains (up to 8,000 feet). The current number of trains passing through Bingen is estimated to increase from 35-39 trains to approximately 56-60 trains per day representing a 50-60% increase in train movements. Freight trains that pass through Bingen without stopping or switching to sidings are estimated to travel at 25 mph, which would translate to an average roadway blockage time of 3.5 minutes. With the estimated increase of about 20 trains per day, the roadways with at-grade rail crossing could experience an additional 70 minutes per day of blockage by train crossings. The two Amtrak passenger trains' daily arrivals (one in each direction) would continue to operate in the future based on a review of Amtrak's operating plan.

6.5 SAFETY

The number of vehicle-related crashes along SR-14 would be expected to increase in the Future No Build conditions on an annual basis due to anticipated increases in traffic volumes, more pronounced congestion levels during peak traffic periods, and seasonal surges in traffic for recreational activities.

6.6 PUBLIC TRANSIT

No additional transit service is planned beyond the additional service that was implemented in 2018. If service on MATS was increased in the future, a change in mode share (e.g., people choosing to travel by public bus instead of passenger vehicle) is not expected to have a substantive reduction in vehicles using SR-14.

6.7 PEDESTRIAN FACILITIES

While pedestrian needs have been identified in the existing conditions review, no major pedestrian facilities were identified to be implemented by the City of Bingen or other local agencies.

6.8 BICYCLE FACILITIES

No new bicycle facilities in the study area were identified.

6.9 PARKING

No plans to increase the future parking supply within the study area have been identified. As background traffic along SR-14 continues to grow into the future, the demand for parking could increase especially during summer months when traffic for recreational activities in the area surges. The supply of parking along SR-14, though currently sufficient for existing demands, may be inadequate to accommodate future demands by 2037.

6.10 HOOD RIVER BRIDGE REPLACEMENT

There is a separate project underway to replace the Hood River Bridge, which would likely include revisions to the SR-14/Hood River Bridge intersection. The traffic analysis and design effort associated with that project would potentially reconfigure the SR-14/Hood River Bridge intersection, including possibly adding capacity, investigating other intersection control types, and/or applying other methods to optimize traffic flow at this intersection. The timing of implementing the bridge replacement project is dependent on funding availability; thus, this project is not included in the Future No Build or Future Build assumptions.

7 FUTURE BUILD CONDITIONS

The SR-14 Bingen/White Salmon Circulation Study also included an analysis of the improvements being developed by WSDOT as part of its Bingen Point Access Project funded through Connecting Washington. Coordination between these two efforts occurred to ensure compatibility in terms of traffic management, intersection control, and community context.

WSDOT developed fourteen concepts to improve access to the Bingen Point Business Park. After a preliminary review, Concept 2 (an overpass near milepost 67.50) and Concept 14 (an undercrossing near Vine Street and connecting with SR-14 at Elm Street) were advanced into a value engineering study. Analysis of these concepts is presented in the following sections. Concept 14 was identified as the most efficient and effective option to improve access to/from the Bingen Point Business Park area; thus, was used to analyze various treatments at the Oak Street and Maple Street intersections on SR-14 and understand the effects on traffic operations in the study area. Improvements to the SR-14 corridor were identified and analyzed to address operational and safety issues that would likely occur over the next 20 years.

7.1 BINGEN POINT ACCESS STUDY CONCEPT 2

For the purposes of this study, Concept 2 as proposed by WSDOT is referred to as “Concept 2 Baseline” to solely reflect the design proposed by WSDOT. No other design improvements along SR-14 were considered as part of Concept 2 Baseline for this study. Concept 2 Baseline is illustrated in Figure 16 and includes the following design components:

- One new intersection on SR-14 approximately 0.8 miles east of Maple Street with stop control on the new roadway that forms the south leg of the intersection
- At this new intersection, a new roadway on the south side of SR-14 would connecting from SR-14 to East Marina Way with a grade-separated crossing over the BNSF railroad tracks
- One eastbound and one westbound through lane on SR-14
- One protected left turn lane for westbound SR-14 to southbound on the new roadway
- One left turn lane and one right turn lane for northbound traffic on the new roadway to westbound and eastbound SR-14
- Realigned driveway on the north side of SR-14 west of the new intersection

Figure 16. Concept 2 Baseline



7.1.1 Future Traffic Volumes and Operational Analysis

Under Concept 2 Baseline, the 2037 PM peak hour traffic volumes and the Intersection LOS for the study area are depicted in Figure 17 and Figure 18, respectively. Compared to the Future No Build traffic volumes, travel patterns would change slightly at Maple Street as a result of the new intersection to the east that would provide access to and from Bingen Point. Delays and Intersection LOS at this new intersection would be similar to the Future No Build. Changes at the SR-14/Maple Street intersection would include:

- Approximately 30% of the traffic that would use Maple Street to access SR-14 from Bingen Point is assumed to reroute to the new intersection⁷. This new intersection would shift an estimated 95 vehicles out of 320 vehicles from the SR-14/Maple Street intersection to the new SR-14 intersection to make a northbound to westbound left turn on SR-14 during the PM peak hour.
- Similarly, 30% of the eastbound to southbound turn movements from SR-14 onto Maple Street (20 vehicles out of 60 vehicles) would shift to the new overcrossing.
- However, because the new roadway connection to Bingen Point would be 0.8-mile from the current access at Maple Street, it is unlikely that enough drivers would shift to the new intersection, and excessive delays at the SR-14/Maple Street intersection would still be experienced during the PM peak hour.

All other study area intersections would perform the same under the Concept 2 Baseline as under the Future No Build as shown in Table 10.

Figure 17. Concept 2 Baseline Traffic Volumes during the PM Peak Hour (2037)

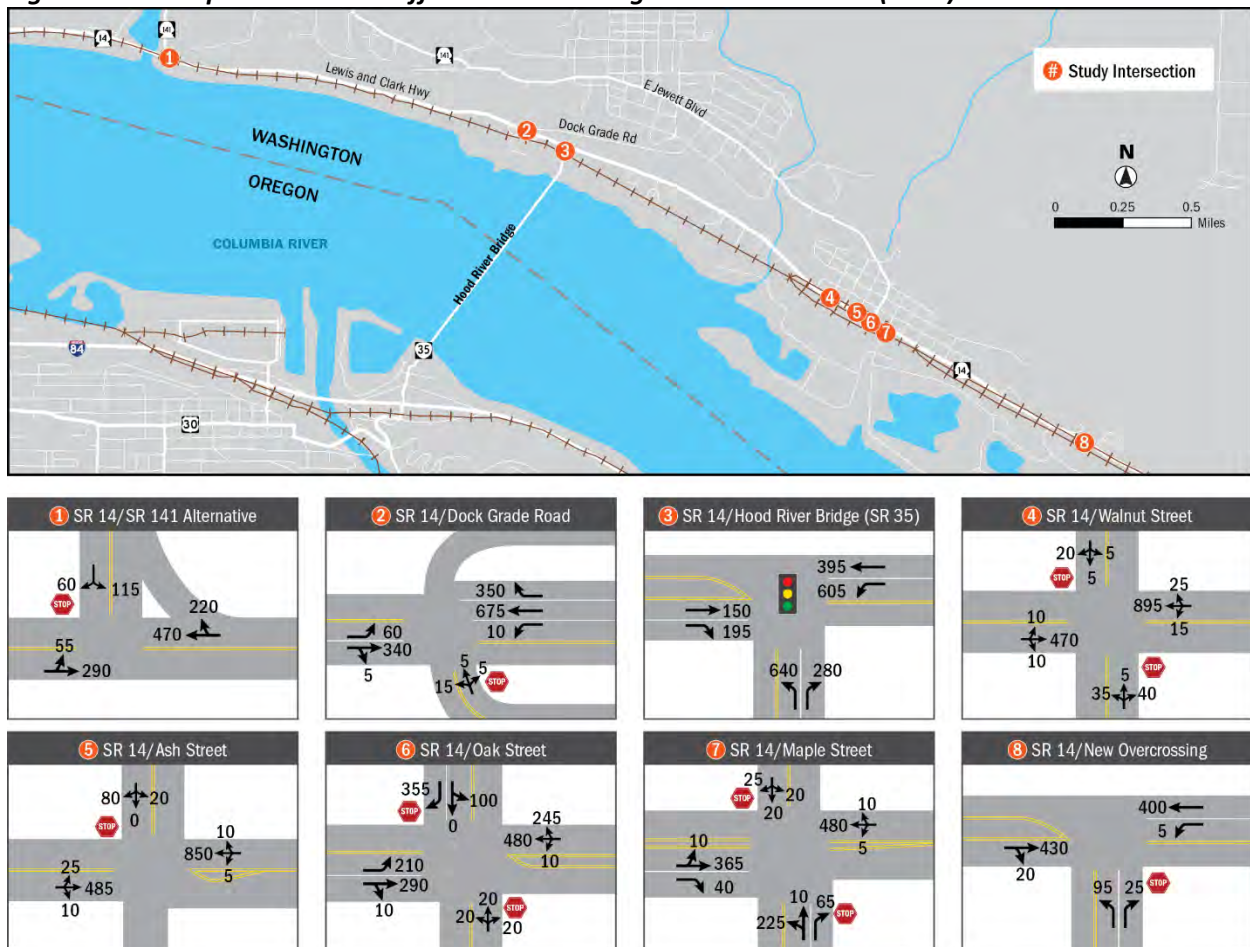

⁷ Travel route shifts were estimated based on driver behavior to likely choose routes based on the shortest travel time, shortest travel distance, and the risk of being stopped by a train crossing. These are typical factors considered in travel demand modeling. As no travel demand model is available for this study area, the travel demand principles were applied to the analysis to estimate route shifts.

Figure 18. Concept 2 Baseline Intersection Levels of Service during the PM Peak Hour (2037)

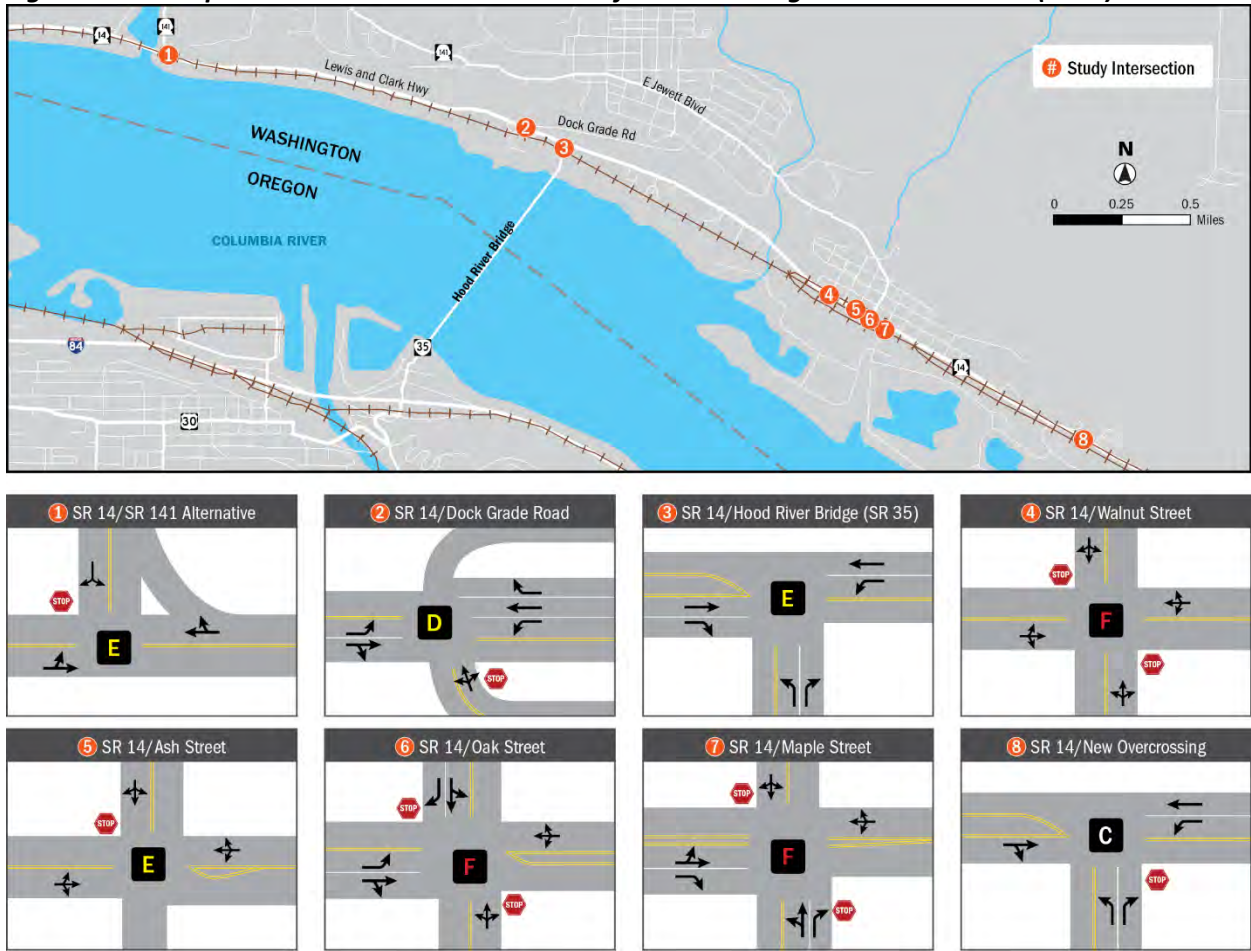

Table 10. Average Vehicle Delay: Concept 2 Baseline Compared to Existing and Future No Build

Intersection		Lane/Movement	Existing (2017)		Future No Build (2037)		Concept 2 Baseline (2037)	
			Delay (sec/veh)	LOS	Delay (sec/veh)	LOS	Delay (sec/veh)	LOS
1	SR-14 and SR-141 Alternative (unsignalized)	EB Through/Left Turn	8.1	A	8.8	A	8.8	A
		WB Through	0.0	A	0.0	A	0.0	A
		SB Left/Right Turn	16.1	C	38.0	E	38.0	E
2	SR-14 and Dock Grade Road (unsignalized)	NB Left/Through/Right	15.3	C	26.9	D	26.9	D
		EB Left Turn	8.6	A	9.5	A	9.5	A
		EB Through/Right Turn	0.0	A	0.0	A	0.0	A
		WB Left Turn	7.8	A	8.1	A	8.1	A
		WB Through	0.0	A	0.0	A	0.0	A
		WB Right Turn	0.0	A	0.0	A	0.0	A
3	SR-14 and Hood River Bridge (SR-35)* (signalized)	EB Through	32.6	C	46.2	D	46.2	D
		EB Right Turn	5.7	A	10.3	B	10.3	B
		WB Left	181.4	F	126.7	F	126.7	F
		WB Through	13.9	B	14.8	B	14.8	B
		NB Left Turn	70.8	E	124.2	F	124.2	F
		NB Right Turn	39.8	D	6.5	A	6.5	A
4	SR-14 and Walnut Street (unsignalized)	NB Left/Through/Right	24.7	C	191.5	F	191.5	F
		EB Left/Through/Right	8.9	A	10.4	B	10.4	B
		WB	8.2	A	8.9	A	8.9	A
		SB Left/Through/Right	19.4	C	40.7	E	40.7	E
5	SR-14 and Ash Street (unsignalized)	EB Left/Through/Right	9.0	A	10.6	B	10.6	B
		WB	8.0	A	8.5	A	8.5	A
		SB Left/Through/Right	17.0	C	46.3	E	46.3	E
6	SR-14 and Oak Street (SR-141) (unsignalized)	NB Left/Through/Right	31.2	D	>300	F	>300	F
		EB Left Turn	9.1	A	11.6	B	11.6	B
		EB Through/Right Turn	0.0	A	0.0	A	0.0	A
		WB	7.7	A	8.1	A	8.1	A
		SB Through/Left Turn	55.8	F	>300	F	>300	F
		SB Right Turn	15.7	C	66.6	F	66.6	F

Intersection		Lane/Movement	Existing (2017)		Future No Build (2037)		Concept 2 Baseline (2037)	
			Delay (sec/veh)	LOS	Delay (sec/veh)	LOS	Delay (sec/veh)	Delay (sec/veh)
7	SR-14 and Maple Street <i>(unsignalized)</i>	NB Through/Left	22.6	C	>300	F	299.1	F
		NB Right Turn	10.1	B	11.5	B	11.4	B
		EB Through/Left	7.8	A	8.3	A	8.6	A
		EB Right Turn	0.0	A	0.0	A	0.0	A
		WB Left/Through/Right	8.0	A	8.4	A	8.4	A
		SB Left/Through/Right	12.8	B	20.6	C	24.1	C
8	SR-14 and New Undercrossing (New Intersection) <i>(unsignalized)</i>	NB Left Turn	N/A	N/A	N/A	N/A	23.4	C
		NB Through/Right	N/A	N/A	N/A	N/A	11.5	B
		EB Through/Right	N/A	N/A	N/A	N/A	0.0	A
		WB Left Turn	N/A	N/A	N/A	N/A	8.7	A
		WB Through	N/A	N/A	N/A	N/A	0.0	A

*Denotes signal modification to adjust timing for northbound to eastbound right turns and westbound to southbound left turns for all future year (2037) conditions.

NB = northbound; SB = southbound; WB = westbound; EB = eastbound

Color coding: LOS A-C (green); LOS D (yellow); LOS E (orange); LOS F with delay less than 300 seconds (red); LOS F with delay more than 300 seconds (black)

7.2 BINGEN POINT ACCESS STUDY CONCEPT 14

An analysis of Concept 14, as designed by WSDOT for the Bingen Point Access Study, was conducted as a standalone concept and referenced as “Concept 14 Baseline.” Later sections in this study provide an analysis of Concept 14 with additional SR-14 design improvements. As shown in Figure 19, Concept 14 Baseline includes the following design components:

- Roundabout at Elm Street that is approximately 0.2 miles east of Maple Street
- A new extension of Elm Street southeast that crosses under the BNSF railroad tracks and connects to East Marina Way

Figure 19. Concept 14 Baseline



7.2.1.1 Future Traffic Volumes

PM peak hour traffic volumes for Concept 14 Baseline in 2037 would be the same as the Future No Build conditions except at the SR-14/Maple Street and SR-14/Elm Street intersections (Figure 20; Note that the volumes shown in this figure also apply to the variations on Concept 14 as described in Section 7.3).

Figure 20. Concept 14 Baseline (and Concepts 14 A1, 14 B1, 14 C, 14 D, and 14 E) Traffic Volumes during the PM Peak Hour (2037)

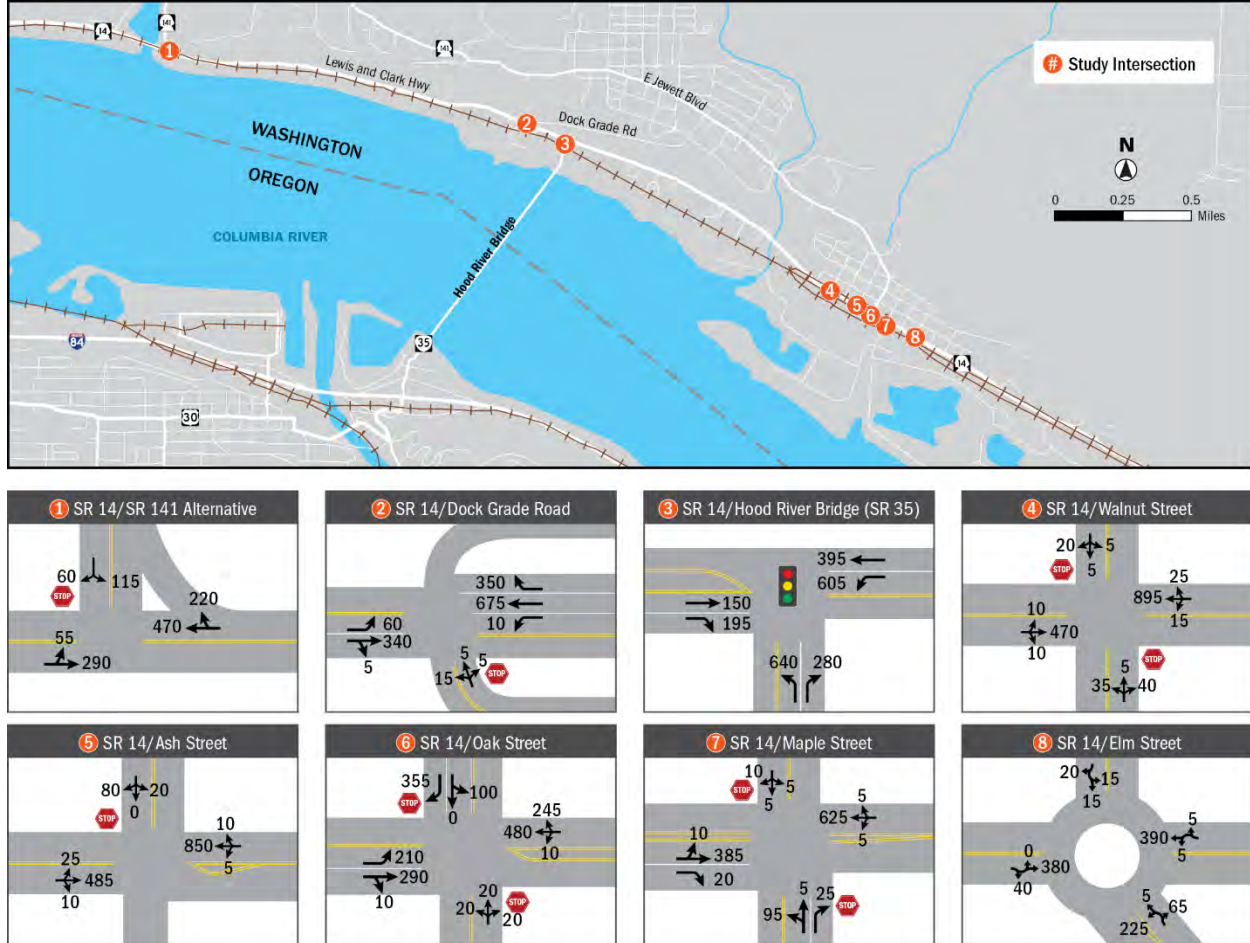

Notes:

- Under Concept 14 A1, SR-14 and Oak Street intersection would be a roundabout*
- Under Concept 14 B1, SR-14 and Oak Street intersection would be signalized*
- Under Concept 14 C SR-14 and Oak Street and SR-14 and Maple Street intersections would be signalized*
- Under Concept 14 D, SR-14 and Oak Street intersection would have all way stop control*
- Under Concept 14 E, SR-14 and Oak Street and SR-14 and Maple Street intersections would have all way stop control*

7.2.1.2 Traffic Operations by Highway Segment

Under Concept 14 Baseline, the Highway LOS analysis shows a projected increase in congestion (LOS E) along Segment 3 in the eastbound direction from Walnut Street to Elm Street (Figure 21). This increased congestion would occur because of the new roundabout at SR-14/Elm Street, which would provide additional access to Bingen Point. Approximately 70 percent of the eastbound SR-14 traffic that would turn right onto southbound Maple Street and traffic making the reverse movement (northbound Maple Street to westbound SR-14) would be shifted from Maple Street to Elm Street⁸. As a result, traffic volumes on SR-14 between Elm Street and Maple Street would increase, which would cause more

⁸ Travel route shifts were estimated based on driver behavior to likely choose routes based on the shortest travel time, shortest travel distance, and the risk of being stopped by a train crossing. These are typical factors considered in travel demand modeling. As no travel demand model is available for this study area, the travel demand principles were applied to the analysis to estimate route shifts.

platooning along Segment 3 and would decrease travel speeds. Westbound traffic operations would be able to maintain a LOS D; however, eastbound traffic operations would degrade to LOS E.

The same impacts to Highway LOS would occur under other intersection treatments that were associated with Concept 14 (Concepts 14 A1, 14 A2, 14 B1, 14 B2, 14 C, 14 D and 14 E, which are discussed in Section 7.3).

Figure 21. SR-14 Highway Segment Levels of Service – Concept 14 Baseline (and Concepts 14 A1, 14 A2, 14 B1, 14 B2, 14 C, 14 D and 14 E)

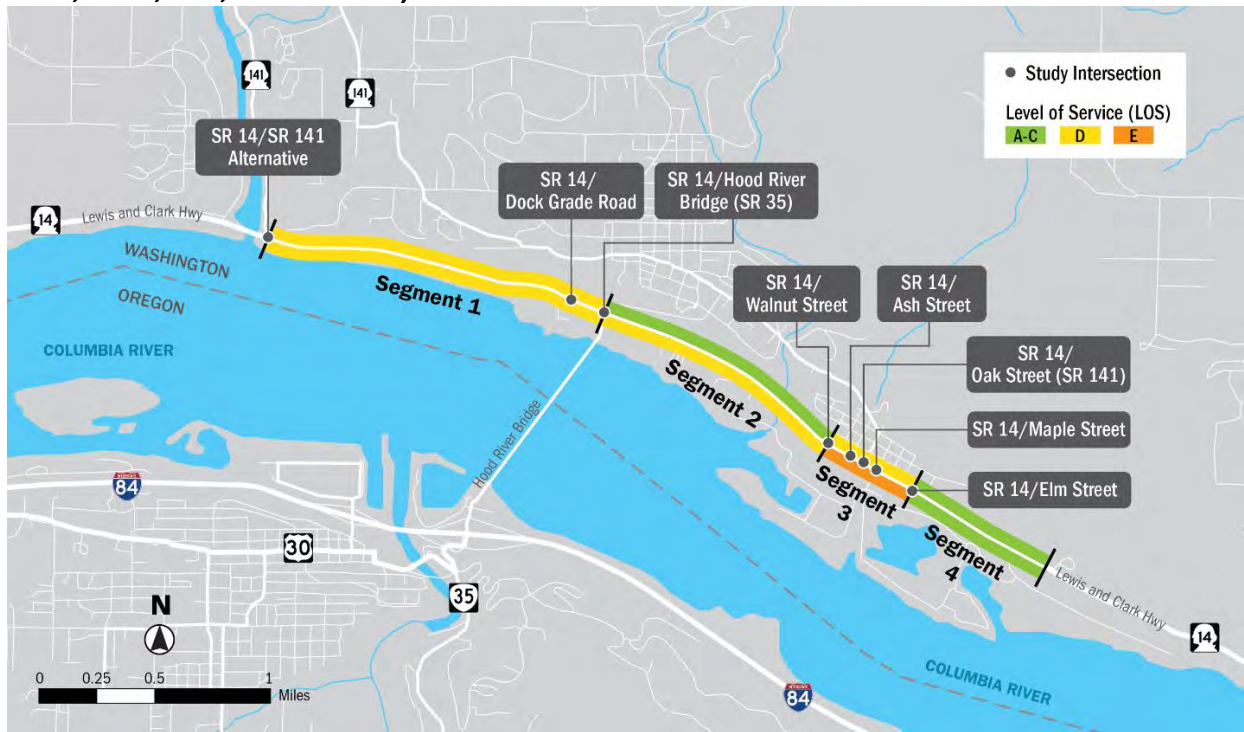

7.2.1.3 Intersection Operations

With a new roundabout intersection on SR-14 that would be 0.2 miles east of Maple Street, traffic circulation would noticeably change with the shift of 70% of the traffic from the SR-14/Maple Street intersection to the new intersection. Specifically:

- Approximately 295 vehicles would shift from the SR-14/Maple Street intersection to the new SR-14/Elm Street intersection to make a similar left turn onto SR-14 through the roundabout and would experience an average vehicle delay of 12.0 seconds to make this movement.
- This route shift would result in reduced delay for vehicles continuing to use the SR-14/Maple Street intersection, particularly the northbound to westbound left turn movement in the PM peak hour. Average delay per vehicle at this intersection would be approximately 80 seconds compared to over 5 minutes (more than 300 seconds) in the Future No Build (Table 11).
- The SR-14/Maple Street intersection would continue to operate at LOS F, although delays for the northbound through/left lane would be substantially reduced (Figure 22).
- The new SR-14/Elm Street roundabout would operate at LOS B.

All other study area intersections would perform the same under the Concept 14 Baseline as under the Future No Build.

Table 11. Average Vehicle Delay: Concept 14 Baseline Compared to Existing and Future No Build

Intersection		Lane/Movement	Existing (2017)		Future No Build (2037)		Concept 14 Baseline (2037)	
			Delay (sec/veh)	LOS	Delay (sec/veh)	LOS	Delay (sec/veh)	LOS
1	SR-14 and SR-141 Alternative (unsignalized)	EB Through/Left Turn	8.1	A	8.8	A	8.8	A
		WB Through	0.0	A	0.0	A	0.0	A
		SB Left/Right Turn	16.1	C	38.0	E	38.0	E
2	SR-14 and Dock Grade Road (unsignalized)	NB Left/Through/Right	15.3	C	26.9	D	26.9	D
		EB Left Turn	8.6	A	9.5	A	9.5	A
		EB Through/Right Turn	0.0	A	0.0	A	0.0	A
		WB Left Turn	7.8	A	8.1	A	8.1	A
		WB Through	0.0	A	0.0	A	0.0	A
		WB Right Turn	0.0	A	0.0	A	0.0	A
3	SR-14 and Hood River Bridge* (signalized)	EB Through	32.6	C	46.2	D	46.2	D
		EB Right Turn	5.7	A	10.3	B	10.3	B
		WB Left	181.4	F	126.7	F	126.7	F
		WB Through	13.9	B	14.8	B	14.8	B
		NB Left Turn	70.8	E	124.2	F	124.2	F
		NB Right Turn	39.8	D	6.5	A	6.5	A
4	SR-14 and Walnut Street (unsignalized)	NB Left/Through/Right	24.7	C	191.5	F	191.5	F
		EB Left/Through/Right	8.9	A	10.4	B	10.4	B
		WB Left/Through/Right	8.2	A	8.9	A	8.9	A
		SB Left/Through/Right	19.4	C	40.7	E	40.7	E
5	SR-14 and Ash Street (unsignalized)	EB Left/Through/Right	9.0	A	10.6	B	10.6	B
		WB Left/Through/Right	8.0	A	8.5	A	8.5	A
		SB Left/Through/Right	17.0	C	46.3	E	46.3	E
6	SR-14 and Oak Street (SR-141) (unsignalized)	NB Left/Through/Right	31.2	D	>300	F	>300	F
		EB Left Turn	9.1	A	11.6	B	11.6	B
		EB Through/Right Turn	0.0	A	0.0	A	0.0	A
		WB Left/Through/Right	7.7	A	8.1	A	8.1	A
		SB Through/Left Turn	55.8	F	>300	F	>300	F
		SB Right Turn	15.7	C	66.6	F	66.6	F

Intersection		Lane/Movement	Existing (2017)		Future No Build (2037)		Concept 14 Baseline (2037)	
			Delay (sec/veh)	LOS	Delay (sec/veh)	LOS	Delay (sec/veh)	LOS
7	SR-14 and Maple Street (unsignalized)	NB Through/Left	22.6	C	>300	F	79.2	F
		NB Right Turn	10.1	B	11.5	B	11.1	B
		EB Through/Left	7.8	A	8.3	A	9.1	A
		EB Right Turn	0.0	A	0.0	A	0.0	A
		WB Left/Through/Right	8.0	A	8.4	A	8.5	A
		SB Left/Through/Right	12.8	B	20.6	C	21.9	C
8	SR-14 and Elm Street (New Intersection) (roundabout)	EB Left/Through/Right	N/A	N/A	N/A	N/A	8.9	A
		WB Left/Through/Right	N/A	N/A	N/A	N/A	11.9	B
		NB Left/Through/Right	N/A	N/A	N/A	N/A	12.0	B
		SB Left/Through/Right	N/A	N/A	N/A	N/A	7.8	A

*Denotes signal modification to adjust timing for northbound to eastbound right turns and westbound to southbound left turns for all future year (2037) conditions.

NB = northbound; SB = southbound; WB = westbound; EB = eastbound

Color coding: LOS A-C (green); LOS D (yellow); LOS E (orange); LOS F with delay less than 300 seconds (red); LOS F with delay more than 300 seconds (black)

Figure 22. Concept 14 Baseline Intersection Levels of Service during the PM Peak Hour (2037)

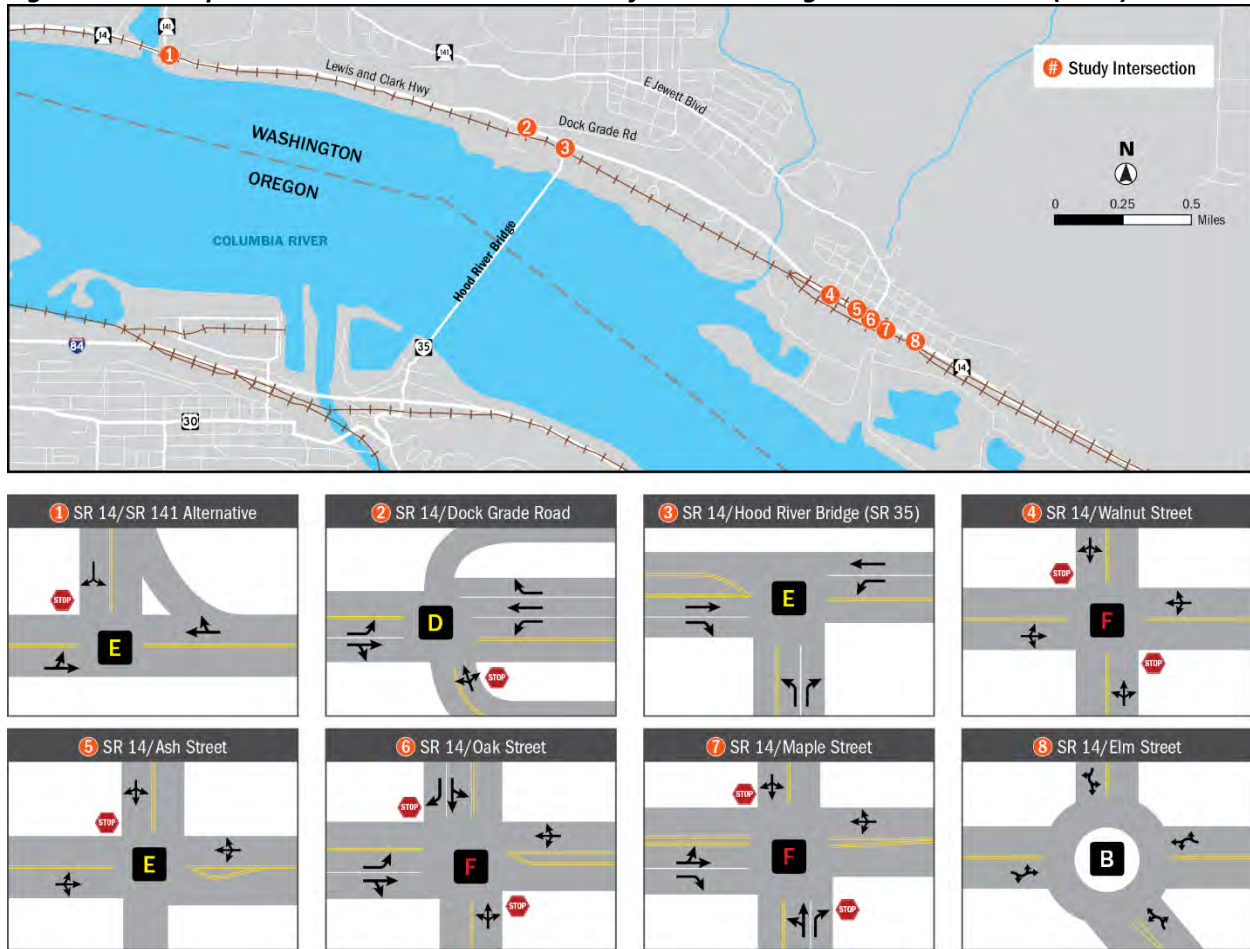

7.3 VARIOUS IMPROVEMENTS TO CONCEPT 14

Concept 14 was used to test several other traffic operational improvement scenarios on SR-14. Through collaboration with WSDOT and RTC, the following improvements at Oak Street and Maple Street were identified and paired with Concept 14 to analyze the potential benefits to circulation on SR-14:

- **Concept 14 A1/A2:** Roundabout at Oak Street
- **Concept 14 B1/B2:** Signal at Oak Street
- **Concept 14 C:** Signals at Oak Street and Maple Street
- **Concept 14 D:** All way stop control at Oak Street
- **Concept 14 E:** All way stop control at Oak Street and Maple Street

These scenarios are identified in Table 12, which also provides a reference to figures that depict their conceptual layout.

Table 12. Scenarios Analyzed in Combination with Concept 14

Concept	Scenario/Improvement	Figure Reference
14	Concept 14 Baseline (as proposed by WSDOT)	Figure 19
14 A1	Concept 14 and roundabout at Oak Street	Figure 23
14 A2	Concept 14 and roundabout at Oak Street with partial restriction at Maple Street	Figure 24
14 B1	Concept 14 and signal at Oak Street	Figure 26
14 B2	Concept 14 and signal at Oak Street with partial restriction at Maple Street	Figure 27
14 C	Concept 14 and signals at Oak and Maple Streets	Figure 29
14 D	Concept 14 and all-way stop control at Oak Street	No figure included
14 E	Concept 14 and all-way stop control at Oak and Maple Streets	No figure included

7.3.1 Concept 14 A1 and Concept 14 A2

In addition to the roundabout at SR-14/Elm Street, Concept 14 A1 and Concept 14 A2 would place a roundabout at the SR-14/Oak Street intersection. Concept 14 A1 would allow through traffic on Maple Street between SR-14 and East Marina Way, whereas Concept 14 A2 would partially restrict (e.g., barrier gate) access on Maple Street. This restricted access would only allow trips to/from SDS Lumber and City of Bingen facilities along Maple Street north of Marina Way, preventing access to Marina Way via Maple Street and requiring trips to/from the Bingen Point Business Park to use the new SR-14/Elm Street roundabout. Figure 23 and Figure 24 illustrate Concept 14 A1 and Concept 14 A2, respectively.

Figure 23. Concept 14 A1



Figure 24. Concept 14 A2



7.3.1.1 Intersection Operations

Based on the average delay per vehicle analysis, the SR-14 intersections at Oak Street and Maple Street would operate significantly better under Concept 14 A1 and Concept 14 A2 compared to the Future No Build where no improvements would be made. Drivers using the new roundabout at SR-14/Elm Street would have minimal delay in passing through the roundabout or using it to travel to/from Bingen Point.

Future traffic volumes at each study intersection for Concept 14 A1 and Concept 14 A2 would be the same as in Concept 14 Baseline (Figure 20). However, the intersection operations for these two concepts would differ (Table 13) at the Oak Street and Maple Street intersections.

For Concept 14 A1:

- SR-14/Oak Street southbound through/left turn lane would have a reduced delay of 47 seconds (LOS E) compared over 5 minutes (LOS F) in the Concept 14 Baseline conditions.
- SR-14/Maple Street would experience reduced delay for the northbound through/left turn lane with 79.2 seconds of average vehicle delay (LOS F) during the PM peak hour compared to over 5 minutes of average vehicle delay in the Future No Build conditions (same delay as Concept 14 Baseline). Thus, adding a roundabout at Oak Street would have little to no beneficial effect on Maple Street queuing and associated average vehicle delay.

When access is partially restricted on to/from Maple Street (Concept 14 A2), traffic operations at the SR-14/Maple Street intersection would be enhanced, and safety at the at-grade Maple Street/railroad crossing would likely improve since most trips would use the Elm Street railroad undercrossing to travel to/from Bingen Point. The following intersection operations for Concept 14 A2 would occur:

- As in Concept 14 A1, SR-14/Oak Street southbound through/left turn lane would have the same reduced delay of 47.0 (LOS E) seconds compared over 5 minutes in the Concept 14 Baseline conditions.

- SR-14/Maple Street northbound through/left turn lane would experience reductions in average delay with 45.7 seconds per vehicle (LOS E) due to less traffic on Maple Street.
- A negligible increase in average delay per vehicle at the SR-14/Elm Street roundabout northbound lane would occur (14.9 seconds as compared with 12.0 seconds under Concept 14 Baseline and Concept 14 A1) due to the partial access restrictions on Maple Street and the shifting of an additional 70 vehicles to this intersection.

Since no changes have been made to the SR-141 Alt, Dock Grade Road, Hood River Bridge, Walnut Street and Ash Street intersections with SR-14, the delay and Intersection LOS results for Concepts 14 A1 and 14 A2 are similar compared to the Future No Build conditions. Intersection LOS for all intersections under these concepts are illustrated in Figure 25.

7.3.1.2 Further Analysis of the Oak Street Roundabout

Sidra software⁹ was used to analyze the roundabout at the SR-14 and Oak Street intersection. Based on the Sidra analysis, the SR-14 and Oak Street intersection would operate with a delay of 18.9 seconds per vehicle and Intersection LOS B for Concepts 14 A1 and 14 A2. However, the westbound SR-14 traffic would have the longest queue entering the roundabout with an average of 20 vehicles that would spill back into the SR-14/Maple Street intersection. The average vehicle delay for this direction would be over a minute (70 seconds) (Intersection LOS F for this movement for Concepts 14 A1 and 14 A2).

The installation of a roundabout at SR-14/Oak Street in tandem with the roundabout at SR-14/Elm Street would provide a more compatible (same traffic control treatment) and continuous flow in traffic by reducing the gaps that occur with signals and all-way stops traffic control treatments. However, for vehicles trying to cross or turn left onto/off SR-14 to other streets (e.g., Maple Street, Cherry Street, and Cedar Street) and driveways between the roundabouts on Oak Street and Elm Street, drivers may have difficulties finding large enough gaps in traffic to make these turns.

An option that could address this “gap acceptance” problem would be installing a center barrier (e.g., curb) on SR-14 between the Oak Street roundabout and Elm Street roundabout. This barrier would restrict all turns to right-in/right-out movements in this segment of SR-14. Left turns and through trips crossing SR-14 would have to travel out-of-direction to use one of the roundabouts to change travel direction. Additionally, a center barrier could potentially further reduce delays and improve safety by removing left turn conflicts at Maple Street. This option was not analyzed as a part of the traffic analysis but could be further investigated.

Another option would include closing the south leg of the SR-14/Maple Street intersection—Maple Street would be closed between SR-14 and Depot Street. This option would reroute traffic destined to/originating from Bingen Point to Oak Street, Depot Street, and then Maple Street. This option was not analyzed as a part of the traffic analysis but could be further investigated.

Both options would maintain Maple Street as a route to Bingen Point in addition to the Elm Street route for traffic able to make right turns onto Maple Street from SR-14 or able to navigate multiple turning movements via the Oak Street-Depot Street- Maple Street route (i.e., passenger vehicles may easily navigate this route compared to freight trucks

⁹ Sidra is WSDOT’s preferred analysis method for roundabouts.

Table 13. Average Vehicle Delay: Concept 14 A1 and Concept 14 A2 Compared to Existing, Future No Build, and Concept 14 Baseline during the PM Peak Hour

	Intersection	Lane/Movement	Existing (2017)		Future No Build (2037)		Concept 14 Baseline (2037)		Concept 14 A1 (2037)		Concept 14 A2 (2037)	
			Delay (sec/veh)	LOS	Delay (sec/veh)	LOS	Delay (sec/veh)	LOS	Delay (sec/veh)	LOS	Delay (sec/veh)	LOS
1	SR-14 and SR-141 Alternative (unsignalized)	EB Through/Left Turn	8.1	A	8.8	A	8.8	A	8.8	A	8.8	A
		WB Through	0.0	A	0.0	A	0.0	A	0.0	A	0.0	A
		SB Left/Right Turn	16.1	C	38.0	E	38.0	E	38.0	E	38.0	E
2	SR-14 and Dock Grade Road (unsignalized)	NB Left/Through/Right	15.3	C	26.9	D	26.9	D	26.9	D	26.9	D
		EB Left Turn	8.6	A	9.5	A	9.5	A	26.9	D	26.9	D
		EB Through/Right Turn	0.0	A	0.0	A	0.0	A	9.5	A	9.5	A
		WB Left Turn	7.8	A	8.1	A	8.1	A	0.0	A	0.0	A
		WB Through	0.0	A	0.0	A	0.0	A	8.1	A	8.1	A
		WB Right Turn	0.0	A	0.0	A	0.0	A	0.0	A	0.0	A
3	SR-14 and Hood River Bridge* (signalized)	EB Through	32.6	C	46.2	D	46.2	D	46.2	D	46.2	D
		EB Right Turn	5.7	A	10.3	B	10.3	B	10.3	B	10.3	B
		WB Left	181.4	F	126.7	F	126.7	F	126.7	F	126.7	F
		WB Through	13.9	B	14.8	B	14.8	B	14.8	B	14.8	B
		NB Left Turn	70.8	E	124.2	F	124.2	F	124.2	F	124.2	F
		NB Right Turn	39.8	D	6.5	A	6.5	A	6.5	A	6.5	A
4	SR-14 and Walnut Street (unsignalized)	NB Left/Through/Right	24.7	C	191.5	F	191.5	F	191.5	F	191.5	F
		EB Left/Through/Right	8.9	A	10.4	B	10.4	B	10.4	B	10.4	B
		WB Left/Through/Right	8.2	A	8.9	A	8.9	A	8.9	A	8.9	A
		SB Left/Through/Right	19.4	C	40.7	E	40.7	E	40.7	E	40.7	E

SR-14 Bingen/White Salmon Circulation Study—Transportation Summary

	Intersection	Lane/Movement	Existing (2017)		Future No Build (2037)		Concept 14 Baseline (2037)		Concept 14 A1 (2037)		Concept 14 A2 (2037)	
			Delay (sec/veh)	LOS	Delay (sec/veh)	LOS	Delay (sec/veh)	LOS	Delay (sec/veh)	LOS	Delay (sec/veh)	LOS
5	SR-14 and Ash Street <i>(unsignalized)</i>	EB Left/Through/Right	9.0	A	10.6	B	10.6	B	10.6	B	10.6	B
		WB Left/Through/Right	8.0	A	8.5	A	8.5	A	8.5	A	8.5	A
		SB Left/Through/Right	17.0	C	46.3	E	46.3	E	46.3	E	46.3	E
6	SR-14 and Oak Street (SR-141) <i>(see notes)</i>	NB Left/Through/Right	31.2 ¹	D	>300 ¹	F	>300 ¹	F	9.7 ²	A	9.7 ²	A
		EB Left Turn	9.1 ¹	A	11.6 ¹	B	11.6 ¹	B	17.1 ²	C	17.1 ²	C
		EB Through/Right Turn	0.0 ¹	A	0.0 ¹	A	0.0 ¹	A				
		WB Left/Through/Right	7.7 ¹	A	8.1 ¹	A	8.1 ¹	A	69.7 ²	F	69.7 ²	F
		SB Through/Left Turn	55.8 ¹	F	>300 ¹	F	>300 ¹	F	47.0 ²	E	47.0 ²	E
		SB Right Turn	15.7 ¹	C	66.6 ¹	F	66.6 ¹	F				
7	SR-14 and Maple Street <i>(unsignalized)</i>	NB Through/Left	22.6	C	>300	F	79.2	F	79.2	F	45.7	E
		NB Right Turn	10.1	B	11.5	B	11.1	B	11.1	B	11.6	B
		EB Through/Left	7.8	A	8.3	A	9.1	A	9.1	A	9.4	A
		EB Right Turn	0.0	A	0.0	A	0.0	A	0.0	A	0.0	A
		WB Left/Through/Right	8.0	A	8.4	A	8.5	A	8.5	A	0.0	A
		SB Left/Through/Right	12.8	B	20.6	C	21.9	C	21.9	C	23.5	C
8	SR-14 and Elm Street (New Intersection) <i>(roundabout)</i>	EB Left/Through/Right	N/A	N/A	N/A	N/A	8.9	A	8.9	A	8.6	A
		WB Left/Through/Right	N/A	N/A	N/A	N/A	11.9	B	11.9	B	14.1	B
		NB Left/Through/Right	N/A	N/A	N/A	N/A	12.0	B	12.0	B	14.9	B
		SB Left/Through/Right	N/A	N/A	N/A	N/A	7.8	A	7.8	A	8.5	A

*Denotes signal modification to adjust timing for northbound to eastbound right turns and westbound to southbound left turns for all future year (2037) conditions.

¹ Intersection is unsignalized with stop control on the minor streets.

² Intersection has a roundabout.

NB = northbound; SB = southbound; WB = westbound; EB = eastbound

Color coding: LOS A-C (green); LOS D (yellow); LOS E (orange); LOS F with delay less than 300 seconds (red); LOS F with delay more than 300 seconds (black)

Figure 25. Concept 14 A1 and Concept 14 A2 Intersection Levels of Service during the PM Peak Hour (2037)

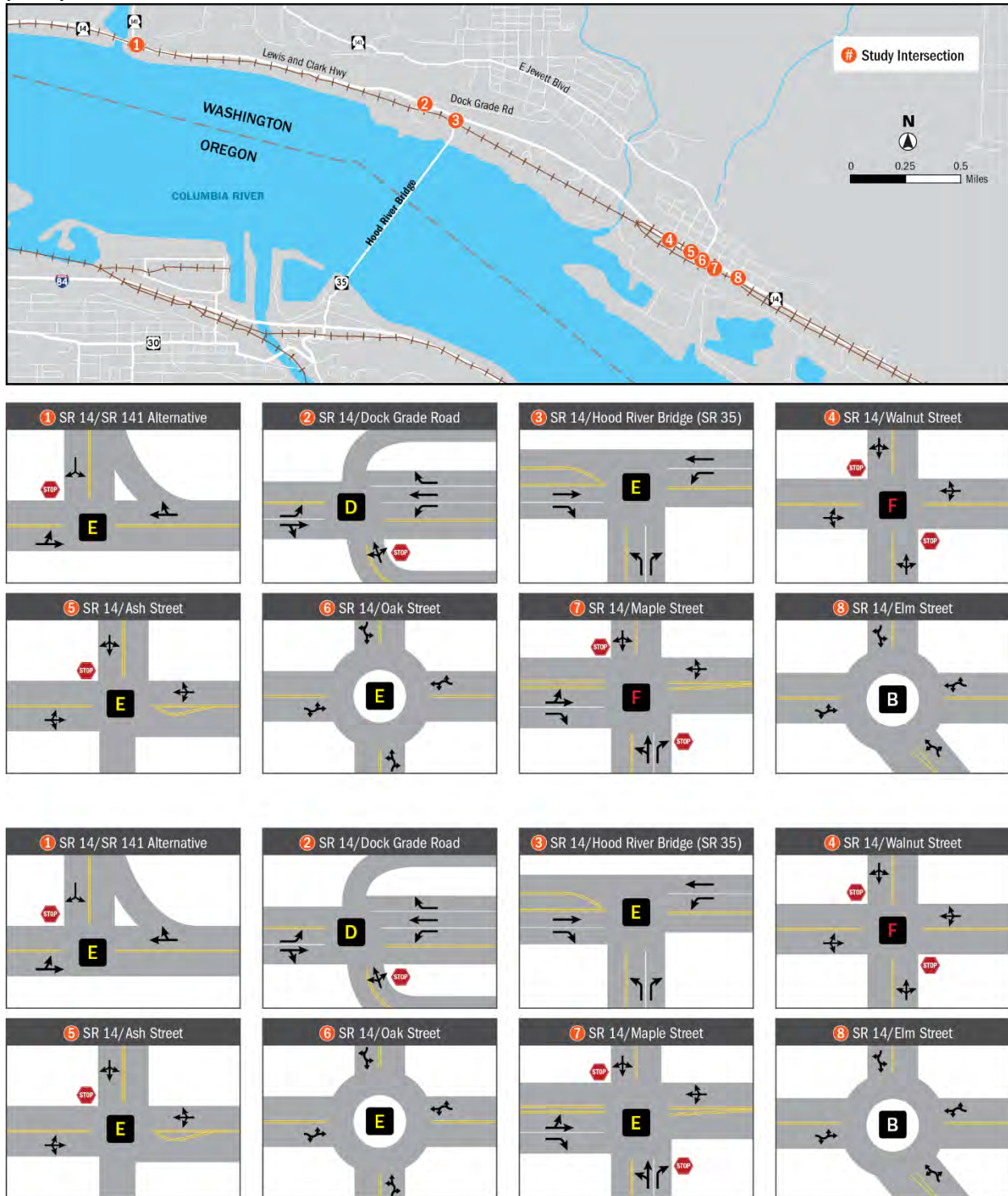

7.3.2 Concept 14 B1 and Concept 14 B2

Concept 14 B1 and Concept 14 B2 would add a signal at the SR-14/Oak Street intersection. Concept 14 B1 would allow through traffic on Maple Street between SR-14 and East Marina Way, whereas Concept 14 B2 would partially restrict (e.g., barrier gate) access on Maple Street. This restricted access would

only allow trips to/from SDS Lumber and City of Bingen facilities along Maple Street north of Marina Way, preventing access to Marina Way via Maple Street and requiring trips to/from the Bingen Point Business Park to use the SR-14/Elm Street roundabout. Figure 26 and Figure 27 illustrate Concept 14 B1 and Concept 14 B2, respectively.

Figure 26. Concept 14 B1



Figure 27. Concept 14 B2



7.3.2.1 Intersection Operations

A signalized intersection at SR-14/Oak Street under Concept 14 B1 and Concept 14 B2 would perform better overall than a roundabout under Concept 14 A1 and Concept 14 A2 in terms of average delay per vehicle. The Intersection LOS ratings are assigned differently for signalized and unsignalized intersections; thus, Concept 14 B1 and Concept 14 B2 would result in an Intersection LOS C for the signalized improvement at Oak Street versus an Intersection LOS E for the roundabout improvement in Concept 14 A1 and Concept 14 A2.

Future traffic volumes at each study intersection for Concept 14 B1 and Concept 14 B2 would be the same as in Concept 14 Baseline (Figure 20). However, due to the added signal at the SR-14/Oak Street intersection, operations at this intersection would differ from Concept 14 Baseline (Table 14) at the Oak Street and Maple Street intersections.

For Concept 14 B1:

- The SR-14/Oak Street signalized intersection would operate better than a roundabout at this intersection with 31.7 seconds of average vehicle delay (Intersection LOS C) under Concept 14 B1 compared to 45.3 seconds of average vehicle delay (Intersection LOS E) under Concepts 14 A1 and 14 A2.

The SR-14/Maple Street intersection would experience the same reduction in average vehicle delay as in Concept 14 Baseline and Concept 14 A1. As noted in Concept 14 A2, when access is partially restricted on to/from Maple Street, traffic operations at the SR-14/Maple Street intersection would be enhanced, and safety at the at-grade Maple Street/railroad crossing would likely improve since most trips would use the Elm Street railroad undercrossing to travel to/from Bingen Point. The following intersection operations for Concept 14 B2 would occur:

- The SR-14/Oak Street signalized intersection would operate the same as Concept 14 B1 with overall reductions in delay compared to the roundabout.
- Like Concept 14 A2, the northbound through/left turn lane at the SR-14/Maple Street intersection would experience further reductions in delay (45.7 seconds (Intersection LOS E) as compared with 79.2 seconds (Intersection LOS F) under Concept 14 Baseline and Concept 14 B1) due to the access restriction on Maple Street. The Maple Street restriction would also result in shifting vehicles to the SR-14/Elm Street roundabout, slightly increasing delay for the westbound (14.1 seconds) and northbound (14.9 seconds) lanes compared to Concept 14 Baseline and Concept 14 B1 (11.9 and 12.0 seconds, respectively).

One notable consideration with the Concept 14 B1 and Concept 14 B2 improvements would be the possible operational incompatibility of signalizing the SR-14/Oak Street intersection while installing a roundabout at the SR-14/Elm Street intersection. These two different intersection control types within a short distance (about 0.2 mile), could potentially confuse drivers. For example, when traveling eastbound, signage before the SR-14/Oak Street intersection would prepare the driver for an upcoming signal with lanes for through movement and turns, but then immediately after the signal the driver would need to interpret different signage about using a roundabout and making a southbound, eastbound, or northbound exit from the roundabout. Changing driver expectations in a short segment could reduce the efficiency at one or both intersections as well as introduce more opportunities for drivers to make mistakes, which could negatively impact safety.

Two other options could be considered to reduce the congestion on this segment of SR-14 as presented in the Concept 14 A1/A2 discussion:

- **Restrict Maple Street to right turns only.** This option would install a barrier in the center median of SR-14 to only allow right turns onto Maple Street and SR-14; all left turns would be prohibited. This treatment would distribute trips to/from Bingen Point Business Park between Maple Street and Elm Street depending on turning movements that drivers would need to make as well as other conditions, including roadway blockage of Maple Street when trains are present.
- **Full closure of the south leg of Maple Street at SR-14.** Maple Street would be closed between SR-14 and Depot Street. Traffic heading south to the Bingen Point Business Park from SR-14 would either use an Oak Street-Depot Street-Maple Street route or use Elm Street.

Both options would maintain Maple Street as a route to Bingen Point in addition to the Elm Street route for traffic able to make right turns onto Maple Street from SR-14 or able to navigate multiple turning movements via the Oak Street-Depot Street- Maple Street route (i.e., passenger vehicles may easily navigate this route compared to freight trucks).

All other intersections would perform the same as Concept 14 Baseline. LOS for Concept 14 B1 and Concept 14 B2 are illustrated in Figure 28.

Table 14. Average Vehicle Delay: Concept 14 B1 and Concept 14 B2 Compared to Existing, Future No Build, and Concept 14 Baseline during the PM Peak Hour

	Intersection	Lane/Movement	Existing (2017)		Future No Build (2037)		Concept 14 Baseline (2037)		Concept 14 B1 (2037)		Concept 14 B2 (2037)	
			Delay (sec/veh)	LOS	Delay (sec/veh)	LOS	Delay (sec/veh)	LOS	Delay (sec/veh)	LOS	Delay (sec/veh)	LOS
1	SR-14 and SR-141 Alternative (unsignalized)	EB Through/Left Turn	8.1	A	8.8	A	8.8	A	8.8	A	8.8	A
		WB Through	0.0	A	0.0	A	0.0	A	0.0	A	0.0	A
		SB Left/Right Turn	16.1	C	38.0	E	38.0	E	38.0	E	38.0	E
2	SR-14 and Dock Grade Road (unsignalized)	NB Left/Through/Right	15.3	C	26.9	D	26.9	D	26.9	D	26.9	D
		EB Left Turn	8.6	A	9.5	A	9.5	A	9.5	A	9.5	A
		EB Through/Right Turn	0.0	A	0.0	A	0.0	A	0.0	A	0.0	A
		WB Left Turn	7.8	A	8.1	A	8.1	A	8.1	A	8.1	A
		WB Through	0.0	A	0.0	A	0.0	A	0.0	A	0.0	A
		WB Right Turn	0.0	A	0.0	A	0.0	A	0.0	A	0.0	A
3	SR-14 and Hood River Bridge* (signalized)	EB Through	32.6	C	46.2	D	46.2	D	46.2	D	46.2	D
		EB Right Turn	5.7	A	10.3	B	10.3	B	10.3	B	10.3	B
		WB Left	181.4	F	126.7	F	126.7	F	126.7	F	126.7	F
		WB Through	13.9	B	14.8	B	14.8	B	14.8	B	14.8	B
		NB Left Turn	70.8	E	124.2	F	124.2	F	124.2	F	124.2	F
		NB Right Turn	39.8	D	6.5	A	6.5	A	6.5	A	6.5	A
4	SR-14 and Walnut Street (unsignalized)	NB Left/Through/Right	24.7	C	191.5	F	191.5	F	191.5	F	191.5	F
		EB Left/Through/Right	8.9	A	10.4	B	10.4	B	10.4	B	10.4	B
		WB Left/Through/Right	8.2	A	8.9	A	8.9	A	8.9	A	8.9	A
		SB Left/Through/Right	19.4	C	40.7	E	40.7	E	40.7	E	40.7	E

SR-14 Bingen/White Salmon Circulation Study—Transportation Summary

	Intersection	Lane/Movement	Existing (2017)		Future No Build (2037)		Concept 14 Baseline (2037)		Concept 14 B1 (2037)		Concept 14 B2 (2037)	
			Delay (sec/veh)	LOS	Delay (sec/veh)	LOS	Delay (sec/veh)	LOS	Delay (sec/veh)	LOS	Delay (sec/veh)	LOS
5	SR-14 and Ash Street <i>(unsignalized)</i>	EB Left/Through/Right	9.0	A	10.6	B	10.6	B	10.6	B	10.6	B
		WB Left/Through/Right	8.0	A	8.5	A	8.5	A	8.5	A	8.5	A
		SB Left/Through/Right	17.0	C	46.3	E	46.3	E	46.3	E	46.3	E
6	SR-14 and Oak Street (SR-141) <i>(see notes)</i>	NB Left/Through/Right	31.2 ¹	D	>300 ¹	F	>300 ¹	F	33.9 ²	C	33.9 ²	C
		EB Left Turn	9.1 ¹	A	11.6 ¹	B	11.6 ¹	B	55.8 ²	E	55.8 ²	E
		EB Through/Right Turn	0.0 ¹	A	0.0 ¹	A	0.0 ¹	A	4.0 ²	A	4.0 ²	A
		WB Left/Through/Right	7.7 ¹	A	8.1 ¹	A	8.1 ¹	A	33.9 ²	C	33.9 ²	C
		SB Through/Left Turn	55.8 ¹	F	>300 ¹	F	>300 ¹	F	39.3 ²	D	39.3 ²	D
		SB Right Turn	15.7 ¹	C	66.6 ¹	F	66.6 ¹	F	34.4 ²	C	34.4 ²	C
7	SR-14 and Maple Street <i>(unsignalized)</i>	NB Through/Left	22.6	C	>300	F	79.2	F	79.2	F	45.7	E
		NB Right Turn	10.1	B	11.5	B	11.1	B	11.1	B	11.6	B
		EB Through/Left	7.8	A	8.3	A	9.1	A	9.1	A	9.4	A
		EB Right Turn	0.0	A	0.0	A	0.0	A	0.0	A	0.0	A
		WB Left/Through/Right	8.0	A	8.4	A	8.5	A	8.5	A	0.0	A
		SB Left/Through/Right	12.8	B	20.6	C	21.9	C	21.9	C	23.5	C
8	SR-14 and Elm Street (New Intersection) <i>(roundabout)</i>	EB Left/Through/Right	N/A	N/A	N/A	N/A	8.9	A	8.9	A	8.6	A
		WB Left/Through/Right	N/A	N/A	N/A	N/A	11.9	B	11.9	B	14.1	B
		NB Left/Through/Right	N/A	N/A	N/A	N/A	12.0	B	12.0	B	14.9	B
		SB Left/Through/Right	N/A	N/A	N/A	N/A	7.8	A	7.8	A	8.5	A

*Denotes signal modification to adjust timing for northbound to eastbound right turns and westbound to southbound left turns for all future year (2037) conditions.

¹ Intersection is unsignalized with stop control on the minor streets.

² Intersection is signalized.

NB = northbound; SB = southbound; WB = westbound; EB = eastbound

Color coding: LOS A-C (green); LOS D (yellow); LOS E (orange); LOS F with delay less than 300 seconds (red); LOS F with delay more than 300 seconds (black)

Figure 28. Concept 14 B1 and Concept 14 B2 Intersection Levels of Service during the PM Peak Hour (2037)

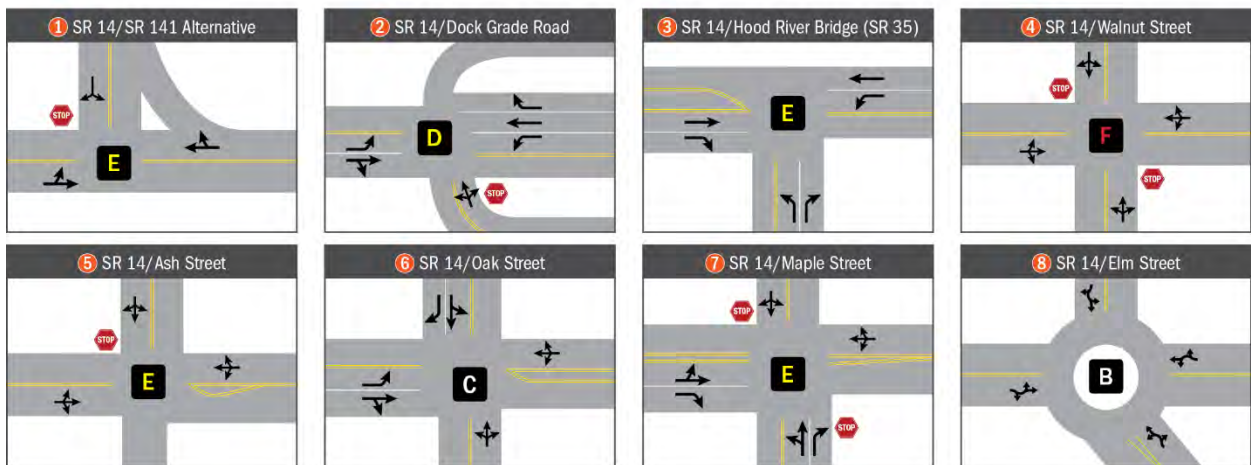
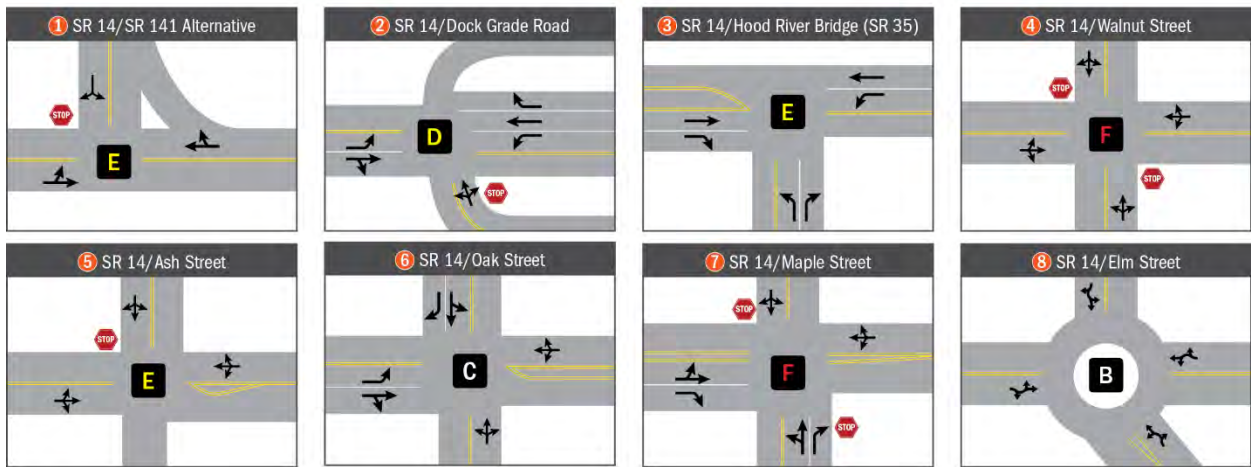

7.3.3 Concept 14 C, Concept 14 D and Concept 14 E

Several additional operational improvements were analyzed in combination with Concept 14 Baseline:

- Concept 14 C would add signals at both the SR-14/Oak Street and the SR-14/Maple Street intersection (Figure 29).
- Concept 14 D would configure the SR-14/Oak Street intersection to be all-way stop controlled.
- Concept 14 E would configure both the SR-14/Oak Street and SR-14/Maple Street intersections to be all-way stop controlled.

Figure 29. Concept 14 C



7.3.3.1 Intersection Operations

Future traffic volumes at each of the intersections under Concepts 14 C, 14 D, and 14 E would be the same as Concept 14 Baseline (Figure 20). Operational differences would again be noted at the SR-14/Oak Street and the SR-14/Maple Street intersections for these concepts (Table 15).

Concept 14 C

Similar to signaling only the SR-14/Oak Street intersection (Concept 14 B1 and Concept 14 B2), operational benefits would be achieved with Concept 14 C where both the SR-14/Oak Street and SR-14/Maple Street intersections are signaled compared to the Future No Build and Concept 14 Baseline (Figure 30). Average delay per vehicle would be reduced from over 5 minutes (LOS F) for the northbound lane and the southbound through/left turn lane to 31.4 seconds (LOS C) and 35.8 seconds (LOS D), respectively, at SR-14/Oak Street. At the SR-14/Maple Street intersection, average vehicle delay for the northbound through/left turn lane would be reduced from 79.2 seconds (LOS F) to 35.6 seconds (LOS D). The delay for the eastbound left turn lane at SR-14/Oak Street would increase from 11.6 seconds (LOS B) to 62.2 seconds (LOS E).

However, it is important to note that the complex signal phasing and signage that would need to occur for these two signals within 500 feet of each other could also introduce confusing signage to drivers as

they attempt to position for turning movements at Oak Street and Maple Street. In addition, the change in drivers' interpretation of signage before intersections and navigating a combination of signalized and roundabout intersections within a short distance could create more confusion, less circulation efficiency, and less safe driving conditions.

Concept 14 D

All way stop control at SR-14/Oak Street would substantially reduce average vehicle delay for the northbound lane to 15.3 seconds (LOS C) compared to Concept 14 Baseline (over 5 minutes; LOS F), and delay for the southbound through/left turn lane would be reduced from over 5 minutes (LOS F) to 14.8 seconds (LOS B). The eastbound and westbound through movements at the intersection would degrade to LOS E and LOS F conditions, respectively, compared to LOS A conditions compared to Future No Build and Concept 14 Baseline conditions. Westbound through movements in this scenario would also queue into the SR-14/Maple Street intersection. Delay at SR-14/Maple Street would be the same as under Concept 14 Baseline.

Concept 14 E

All way stop control at both SR-14/Oak Street and SR-14/Maple Street would substantially reduce average vehicle delay for northbound and southbound movements at these intersections compared to Concept 14 Baseline. The delays at SR-14/Oak Street would be the same as Concept 14D. At the SR-14/Maple Street intersection the delay for the northbound through/left turn lane would be reduced from 79.2 seconds (LOS F) under Concept 14 Baseline to 13.2 seconds (LOS B). However, the westbound through movement would worsen considerably compared to Concept 14 D. Not only would westbound traffic spillback from the Oak Street intersection into the Maple Street intersection, it would spill back from the Maple Street intersection past Cherry Street.

Furthermore, the introduction of all-way stop control intersections at Oak Street and Maple Street intersection under both Concepts 14 D and 14 E may create a confusing driving experience and an incompatible operating system with the roundabout at SR-14/Elm Street, which is 0.25 mile east of Oak Street and 0.2 miles from Maple Street.

7.4 SUMMARY OF ALL BUILD CONDITIONS

A comparison of delay and LOS for all build concepts is provided in Table 16.

Table 15. Average Vehicle Delay: Concept 14 C, Concept 14 D and Concept 14 E Compared to Existing, Future No Build, and Concept 14 Baseline during the PM Peak Hour

	Intersection	Lane/Movement	Existing (2017)		Future No Build (2037)		Concept 14 Baseline (2037)		Concept 14 C (2037)		Concept 14 D (2037)		Concept 14 E (2037)	
			Delay (sec/veh)	LOS	Delay (sec/veh)	LOS	Delay (sec/veh)	LOS	Delay (sec/veh)	LOS	Delay (sec/veh)	LOS	Delay (sec/veh)	LOS
1	SR-14 and SR-141 Alternative (unsignalized)	EB Through/Left Turn	8.1	A	8.8	A	8.8	A	8.8	A	8.8	A	8.8	A
		WB Through	0.0	A	0.0	A	0.0	A	0.0	A	0.0	A	0.0	A
		SB Left/Right Turn	16.1	C	38.0	E	38.0	E	38.0	E	38.0	E	38.0	E
2	SR-14 and Dock Grade Road (unsignalized)	NB Left/Through/Right	15.3	C	26.9	D	26.9	D	26.9	D	26.9	D	26.9	D
		EB Left Turn	8.6	A	9.5	A	9.5	A	9.5	A	9.5	A	9.5	A
		EB Through/Right Turn	0.0	A	0.0	A	0.0	A	0.0	A	0.0	A	0.0	A
		WB Left Turn	7.8	A	8.1	A	8.1	A	8.1	A	8.1	A	8.1	A
		WB Through	0.0	A	0.0	A	0.0	A	0.0	A	0.0	A	0.0	A
		WB Right Turn	0.0	A	0.0	A	0.0	A	0.0	A	0.0	A	0.0	A
3	SR-14 and Hood River Bridge* (signalized)	EB Through	32.6	C	46.2	D	46.2	D	46.2	D	46.2	D	46.2	D
		EB Right Turn	5.7	A	10.3	B	10.3	B	10.3	B	10.3	B	10.3	B
		WB Left	181.4	F	126.7	F	126.7	F	126.7	F	126.7	F	126.7	F
		WB Through	13.9	B	14.8	B	14.8	B	14.8	B	14.8	B	14.8	B
		NB Left Turn	70.8	E	124.2	F	124.2	F	124.2	F	124.2	F	124.2	F
		NB Right Turn	39.8	D	6.5	A	6.5	A	6.5	A	6.5	A	6.5	A
4	SR-14 and Walnut Street (unsignalized)	NB Left/Through/Right	24.7	C	191.5	F	191.5	F	191.5	F	191.5	F	191.5	F
		EB Left/Through/Right	8.9	A	10.4	B	10.4	B	10.4	B	10.4	B	10.4	B
		WB Left/Through/Right	8.2	A	8.9	A	8.9	A	8.9	A	8.9	A	8.9	A
		SB Left/Through/Right	19.4	C	40.7	E	40.7	E	40.7	E	40.7	E	40.7	E
5	SR-14 and Ash Street (unsignalized)	EB Left/Through/Right	9.0	A	10.6	B	10.6	B	10.6	B	10.6	B	10.6	B
		WB Left/Through/Right	8.0	A	8.5	A	8.5	A	8.5	A	8.5	A	8.5	A
		SB Left/Through/Right	17.0	C	46.3	E	46.3	E	46.3	E	46.3	E	46.3	E
6	SR-14 and Oak Street (SR-141) (see notes)	NB Left/Through/Right	31.2 ¹	D	>300 ¹	F	>300 ¹	F	31.4 ²	C	15.3 ³	C	15.3 ³	C
		EB Left Turn	9.1 ¹	A	11.6 ¹	B	11.6 ¹	B	62.2 ²	E	23.7 ³	C	23.7 ³	C
		EB Through/Right Turn	0.0 ¹	A	0.0 ¹	A	0.0 ¹	A	4.1 ²	A	40.6 ³	E	40.6 ³	E
		WB Left/Through/Right	7.7 ¹	A	8.1 ¹	A	8.1 ¹	A	21.0 ²	C	70.0 ³	F	70.0 ³	F
		SB Through/Left Turn	55.8 ¹	F	>300 ¹	F	>300 ¹	F	35.8 ²	D	14.8 ³	B	14.8 ³	B
		SB Right Turn	15.7 ¹	C	66.6 ¹	F	66.6 ¹	F	31.9 ²	C	43.6 ³	E	43.6 ³	E

	Intersection	Lane/Movement	Existing (2017)		Future No Build (2037)		Concept 14 Baseline (2037)		Concept 14 C (2037)		Concept 14 D (2037)		Concept 14 E (2037)	
			Delay (sec/veh)	LOS	Delay (sec/veh)	LOS	Delay (sec/veh)	LOS	Delay (sec/veh)	LOS	Delay (sec/veh)	LOS	Delay (sec/veh)	LOS
7	SR-14 and Maple Street (unsignalized)	NB Through/Left	22.6 ¹	C	>300 ¹	F	79.2 ¹	F	35.6 ²	D	79.2 ¹	F	13.2 ³	B
		NB Right Turn	10.1 ¹	B	11.5 ¹	B	11.1 ¹	B	30.0 ²	C	11.1 ¹	B	9.7 ³	A
		EB Through/Left	7.8 ¹	A	8.3 ¹	A	9.1 ¹	A	4.1 ²	A	9.1 ¹	A	21.4 ³	C
		EB Right Turn	0.0 ¹	A	0.0 ¹	A	0.0 ¹	A	3.1 ²	A	0.0 ¹	A	8.2 ³	A
		WB Left/Through/Right	8.0 ¹	A	8.4 ¹	A	8.5 ¹	A	22.7 ²	C	8.5 ¹	A	62.4 ³	F
		SB Left/Through/Right	12.8 ¹	B	20.6 ¹	C	21.9 ¹	C	30.3 ²	C	21.9 ¹	C	11.1 ³	B
8	SR-14 and Elm Street (New Intersection) (roundabout)	EB Left/Through/Right	N/A	N/A	N/A	N/A	8.9	A	8.9	A	8.9	A	8.9	A
		WB Left/Through/Right	N/A	N/A	N/A	N/A	11.9	B	11.9	B	11.9	B	11.9	B
		NB Left/Through/Right	N/A	N/A	N/A	N/A	12.0	B	12.0	B	12.0	B	12.0	B
		SB Left/Through/Right	N/A	N/A	N/A	N/A	7.8	A	7.8	A	7.8	A	7.8	A

*Denotes signal modification to adjust timing for northbound to eastbound right turns and westbound to southbound left turns for all future year (2037) conditions.

¹ Intersection is unsignalized with stop control on the minor streets.

² Intersection is signalized.

³ Intersection is all way stop controlled.

NB = northbound; SB = southbound; WB = westbound; EB = eastbound

Color coding: LOS A-C (green); LOS D (yellow); LOS E (orange); LOS F with delay less than 300 seconds (red); LOS F with delay more than 300 seconds (black)

Figure 30. Concept 14 C Intersection Levels of Service during the PM Peak Hour (2037)

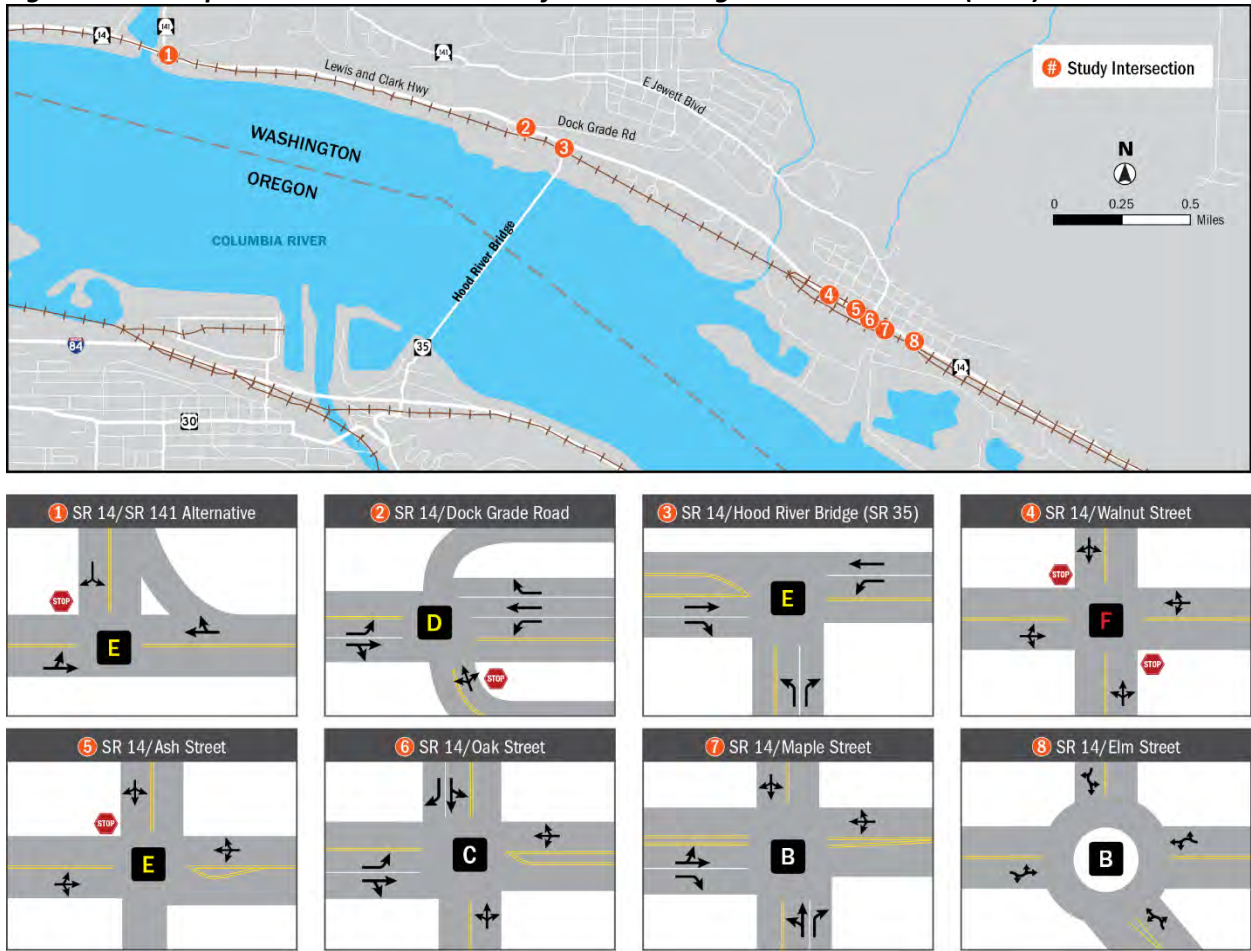

Table 16. Average Vehicle Delay: Comparison of Existing, Future No Build, and All Build Concepts during the PM Peak Hour

Intersection	Lane/Movement	Existing (2017)		Future No Build (2037)		Concept 2 Baseline (2037)		Concept 14 Baseline (2037)		Concept 14 A1 (2037)		Concept 14 A2 (2037)		Concept 14 B1 (2037)		Concept 14 B2 (2037)		Concept 14 C (2037)		Concept 14 D (2037)		Concept 14 E (2037)	
		Delay (sec/veh)	LOS	Delay (sec/veh)	LOS	Delay (sec/veh)	LOS	Delay (sec/veh)	LOS	Delay (sec/veh)	LOS	Delay (sec/veh)	LOS	Delay (sec/veh)	LOS	Delay (sec/veh)	LOS	Delay (sec/veh)	LOS	Delay (sec/veh)	LOS	Delay (sec/veh)	LOS
1 SR-14 and SR-141 Alternative (unsignalized)	EB Through/Left Turn	8.1	A	8.8	A	8.8	A	8.8	A	8.8	A	8.8	A	8.8	A	8.8	A	8.8	A	8.8	A	8.8	A
	WB Through	0.0	A	0.0	A	0.0	A	0.0	A	0.0	A	0.0	A	0.0	A	0.0	A	0.0	A	0.0	A	0.0	A
	SB Left/Right Turn	16.1	C	38.0	E	38.0	E	38.0	E	38.0	E	38.0	E	38.0	E	38.0	E	38.0	E	38.0	E	38.0	E
2 SR-14 and Dock Grade Road (unsignalized)	NB Left/Through/Right	15.3	C	26.9	D	26.9	D	26.9	D	26.9	D	26.9	D	26.9	D	26.9	D	26.9	D	26.9	D	26.9	D
	EB Left Turn	8.6	A	9.5	A	9.5	A	9.5	A	26.9	D	26.9	D	9.5	A	9.5	A	9.5	A	9.5	A	9.5	A
	EB Through/Right Turn	0.0	A	0.0	A	0.0	A	0.0	A	9.5	A	9.5	A	0.0	A	0.0	A	0.0	A	0.0	A	0.0	A
	WB Left Turn	7.8	A	8.1	A	8.1	A	8.1	A	0.0	A	0.0	A	8.1	A	8.1	A	8.1	A	8.1	A	8.1	A
	WB Through	0.0	A	0.0	A	0.0	A	0.0	A	8.1	A	8.1	A	0.0	A	0.0	A	0.0	A	0.0	A	0.0	A
	WB Right Turn	0.0	A	0.0	A	0.0	A	0.0	A	0.0	A	0.0	A	0.0	A	0.0	A	0.0	A	0.0	A	0.0	A
3 SR-14 and Hood River Bridge* (signalized)	EB Through	32.6	C	46.2	D	46.2	D	46.2	D	46.2	D	46.2	D	46.2	D	46.2	D	46.2	D	46.2	D	46.2	D
	EB Right Turn	5.7	A	10.3	B	10.3	B	10.3	B	10.3	B	10.3	B	10.3	B	10.3	B	10.3	B	10.3	B	10.3	B
	WB Left	181.4	F	126.7	F	126.7	F	126.7	F	126.7	F	126.7	F	126.7	F	126.7	F	126.7	F	126.7	F	126.7	F
	WB Through	13.9	B	14.8	B	14.8	B	14.8	B	14.8	B	14.8	B	14.8	B	14.8	B	14.8	B	14.8	B	14.8	B
	NB Left Turn	70.8	E	124.2	F	124.2	F	124.2	F	124.2	F	124.2	F	124.2	F	124.2	F	124.2	F	124.2	F	124.2	F
	NB Right Turn	39.8	D	6.5	A	6.5	A	6.5	A	6.5	A	6.5	A	6.5	A	6.5	A	6.5	A	6.5	A	6.5	A
4 SR-14 and Walnut Street (unsignalized)	NB Left/Through/Right	24.7	C	191.5	F	191.5	F	191.5	F	191.5	F	191.5	F	191.5	F	191.5	F	191.5	F	191.5	F	191.5	F
	EB Left/Through/Right	8.9	A	10.4	B	10.4	B	10.4	B	10.4	B	10.4	B	10.4	B	10.4	B	10.4	B	10.4	B	10.4	B
	WB Left/Through/Right	8.2	A	8.9	A	8.9	A	8.9	A	8.9	A	8.9	A	8.9	A	8.9	A	8.9	A	8.9	A	8.9	A
	SB Left/Through/Right	19.4	C	40.7	E	40.7	E	40.7	E	40.7	E	40.7	E	40.7	E	40.7	E	40.7	E	40.7	E	40.7	E
5 SR-14 and Ash Street (unsignalized)	EB Left/Through/Right	9.0	A	10.6	B	10.6	B	10.6	B	10.6	B	10.6	B	10.6	B	10.6	B	10.6	B	10.6	B	10.6	B
	WB Left/Through/Right	8.0	A	8.5	A	8.5	A	8.5	A	8.5	A	8.5	A	8.5	A	8.5	A	8.5	A	8.5	A	8.5	A
	SB Left/Through/Right	17.0	C	46.3	E	46.3	E	46.3	E	46.3	E	46.3	E	46.3	E	46.3	E	46.3	E	46.3	E	46.3	E
6 SR-14 and Oak Street (SR-141) (see notes)	NB Left/Through/Right	31.2 ¹	D	>300 ¹	F	>300 ¹	F	>300 ¹	F	9.7 ³	A	9.7 ³	A	33.9 ²	C	33.9 ²	C	31.4 ²	C	15.3 ⁴	C	15.3 ⁴	C
	EB Left Turn	9.1 ¹	A	11.6 ¹	B	11.6 ¹	B	11.6 ¹	B	17.1 ³	C	17.1 ³	C	55.8 ²	E	55.8 ²	E	62.2 ²	E	23.7 ⁴	C	23.7 ⁴	C
	EB Through/Right Turn	0.0 ¹	A	0.0 ¹	A	0.0 ¹	A	0.0 ¹	A					4.0 ²	A	4.0 ²	A	4.1 ²	A	40.6 ⁴	E	40.6 ⁴	E
	WB Left/Through/Right	7.7 ¹	A	8.1 ¹	A	8.1 ¹	A	8.1 ¹	A	69.7 ³	F	69.7 ³	F	33.9 ²	C	33.9 ²	C	21.0 ²	C	70.0 ⁴	F	70.0 ⁴	F
	SB Through/Left Turn	55.8 ¹	F	>300 ¹	F	>300 ¹	F	>300 ¹	F	47.0 ³	E	47.0 ³	E	39.3 ²	D	39.3 ²	D	35.8 ²	D	14.8 ⁴	B	14.8 ⁴	B
	SB Right Turn	15.7 ¹	C	66.6 ¹	F	66.6 ¹	F	66.6 ¹	F					34.4 ²	C	34.4 ²	C	31.9 ²	C	43.6 ⁴	E	43.6 ⁴	E

Intersection	Lane/Movement	Existing (2017)		Future No Build (2037)		Concept 2 Baseline (2037)		Concept 14 Baseline (2037)		Concept 14 A1 (2037)		Concept 14 A2 (2037)		Concept 14 B1 (2037)		Concept 14 B2 (2037)		Concept 14 C (2037)		Concept 14 D (2037)		Concept 14 E (2037)		
		Delay (sec/veh)	LOS	Delay (sec/veh)	LOS	Delay (sec/veh)	LOS	Delay (sec/veh)	LOS	Delay (sec/veh)	LOS	Delay (sec/veh)	LOS	Delay (sec/veh)	LOS	Delay (sec/veh)	LOS	Delay (sec/veh)	LOS	Delay (sec/veh)	LOS	Delay (sec/veh)	LOS	
7	SR-14 and Maple Street <i>(see notes)</i>	NB Through/Left	22.6 ¹	C	>300 ¹	F	299.1 ¹	F	79.2 ¹	F	79.2 ¹	F	45.7 ¹	E	79.2 ¹	F	45.7 ¹	E	35.6 ²	D	79.2 ¹	F	13.2 ⁴	B
		NB Right Turn	10.1 ¹	B	11.5 ¹	B	11.4 ¹	B	11.1 ¹	B	11.1 ¹	B	11.6 ¹	B	11.1 ¹	B	11.6 ¹	B	30.0 ²	C	11.1 ¹	B	9.7 ⁴	A
		EB Through/Left	7.8 ¹	A	8.3 ¹	A	8.6 ¹	A	9.1 ¹	A	9.1 ¹	A	9.4 ¹	A	9.1 ¹	A	9.4 ¹	A	4.1 ²	A	9.1 ¹	A	21.4 ⁴	C
		EB Right Turn	0.0 ¹	A	0.0 ¹	A	0.0 ¹	A	0.0 ¹	A	0.0 ¹	A	0.0 ¹	A	0.0 ¹	A	0.0 ¹	A	3.1 ²	A	0.0 ¹	A	8.2 ⁴	A
		WB Left/Through/Right	8.0 ¹	A	8.4 ¹	A	8.4 ¹	A	8.5 ¹	A	8.5 ¹	A	0.0 ¹	A	8.5 ¹	A	0.0 ¹	A	22.7 ²	C	8.5 ¹	A	62.4 ⁴	F
		SB Left/Through/Right	12.8 ¹	B	20.6 ¹	C	24.1 ¹	C	21.9 ¹	C	21.9 ¹	C	23.5 ¹	C	21.9 ¹	C	23.5 ¹	C	30.3 ²	C	21.9 ¹	C	11.1 ⁴	B
8	SR-14 and New Undercrossing or Elm Street (New Intersection) <i>(see notes)</i>	EB Left/Through/Right	N/A	N/A	N/A	N/A	23.4 ¹	C	8.9 ³	A	8.9 ³	A	8.6 ³	A	8.9 ³	A	8.6 ³	A	8.9 ³	A	8.9 ³	A	8.9 ³	A
		WB Left/Through/Right	N/A	N/A	N/A	N/A	11.5 ¹	B	11.9 ³	B	11.9 ³	B	14.1 ³	B	11.9 ³	B	14.1 ³	B	11.9 ³	B	11.9 ³	B	11.9 ³	B
		NB Left/Through/Right	N/A	N/A	N/A	N/A	0.0 ¹	A	12.0 ³	B	12.0 ³	B	14.9 ³	B	12.0 ³	B	14.9 ³	B	12.0 ³	B	12.0 ³	B	12.0 ³	B
		SB Left/Through/Right	N/A	N/A	N/A	N/A	8.7 ¹	A	7.8 ³	A	7.8 ³	A	8.5 ³	A	7.8 ³	A	8.5 ³	A	7.8 ³	A	7.8 ³	A	7.8 ³	A

*Denotes signal modification to adjust timing for northbound to eastbound right turns and westbound to southbound left turns for all future year (2037) conditions.

¹ Intersection is unsignalized with stop control on the minor streets.

² Intersection is signalized.

³ Intersection has a roundabout.

⁴ Intersection is all way stop controlled.

NB = northbound; SB = southbound; WB = westbound; EB = eastbound

Color coding: LOS A-C (green); LOS D (yellow); LOS E (orange); LOS F with delay less than 300 seconds (red); LOS F with delay more than 300 seconds (black)

7.5 RAIL CONSIDERATIONS

As described in Section 6.4, by 2037 the number of trains operating on the BNSF (Fallbridge Division) rail corridor are expected to increase from 35-39 trains in 2017 to up to 60 trains per day. In addition, many of the freight trains would be unit trains up to 8,000 feet long, with crossing times (roadway blockages) up to 3.5 minutes. To assess the impacts that train movements and blockages at the Maple Street rail crossing would have on SR-14 intersection operations, an analysis of the Future No Build and selected Build conditions (Concept 14 Baseline and Concept 14 B2) was performed using Vissim analysis software. Vissim software is a commonly used microsimulation platform for examining complex traffic conflicts and movements, including those involving non-linear traffic demands such as freight train movements.

For the purposes of this analysis, two unit trains with 3.5-minute blockage times and one local train with a 3-minute blockage time were assumed during the PM peak period. The study area for the Vissim Analysis evaluated SR-14 from Ash Street to Elm Street. The Vissim operational analysis results are provided in Table 17.

Table 17. Average Vehicle Delay: Select Intersections during the PM Peak Hour During Train Crossings (2037)

Intersection	Future No Build PM Peak		Build PM Peak			
	Delay (sec/veh)	LOS	Concept 14 Baseline		Concept 14 B2	
			Delay (sec/veh)	LOS	Delay (sec/veh)	LOS
SR-14 and Ash Street (<i>unsignalized</i>)	56	F	41	E	22	C
SR-14 and Oak Street (SR-141) (<i>see notes</i>)	37 ¹	E	36 ¹	E	19 ²	B
SR-14 and Maple Street (<i>unsignalized</i>)	51	F	30	D	63	F
SR-14 and Elm Street (<i>unsignalized</i>)	N/A	N/A	9	A	12	B

Note: Analysis assumes 2 unit trains (3.5-minute blockage) and 1 local train (3-minute blockage) during PM peak hour.

¹ Intersection is unsignalized.

² Intersection is signalized.

Based on the Vissim operational analysis, the intersections would fail (LOS E or LOS F) under the Future No Build conditions with trains crossing during the PM peak hour. However, the projected average vehicle delays at the Oak Street and Maple Street intersections would be much lower than those reported in the Synchro Analysis, which is largely due to the metering effect of train blockages that can be factored into the Vissim software. In other words, the blockages by trains would constrain Maple Street traffic levels south of the rail crossing and would create gaps on SR-14, allowing traffic on Oak Street to more efficiently turn onto SR-14. Synchro traffic analysis software is unable to account for these rail blockages and associated gaps, and therefore reports delays that can be significantly different between the two software programs.

Under Concept 14 Baseline, both the Oak Street and the Ash Street intersections on SR-14 would operate at LOS E. However, delays at the SR-14/Maple Street intersection would be reduced compared to the Future No Build conditions, improving to LOS D, because of lower vehicle traffic volumes associated with traffic shifting to the Elm Street roundabout.

Under Concept 14 B2, which includes a signal at Oak Street and partial access restriction for Maple Street, both the Oak Street and Ash Street intersections would operate at LOS C or better. The signal at SR-14/Oak Street would meter traffic, which would also create gaps on SR-14 for vehicles turning onto SR-14 from Ash Street. However, due to the proximity of the proposed Oak Street signal to Maple Street, the westbound queues on SR-14 from Oak Street would extend through the Maple Street intersection, which would increase overall delays at Maple Street, resulting in a longer delay (63 seconds) than the Future No Build and Concept 14 Baseline.

8 CONCLUSION

In the existing conditions (2017) analysis, traffic flow on SR-14 in the study area meets the highway operational standard of LOS C during the PM peak hour except for the eastbound segment from the SR-14/SR-141 Alt intersection to the SR-14/Hood River Bridge intersection. Under the Future No Build conditions (2037), vehicle volumes, average vehicle delay, and congestion would increase, negatively impacting traffic flow along other highway segments as well as intersection operations within the study area.

In August 2017, WSDOT identified Concept 14 as the preferred new grade-separated railroad crossing for access to the Bingen Point. This concept would provide a new railroad undercrossing and roundabout on SR-14 at Elm Street—roughly 0.2 miles east of Maple Street. Compared to the Future No Build Conditions and another concept studied (Concept 2), Concept 14 is expected to have the highest utilization of trips from/to Bingen Point and would provide the greatest opportunity to avoid delays associated with train crossings at Maple Street.

Various concepts were analyzed at the Oak Street and Maple Street intersections on SR-14 that could be paired with WSDOT's Concept 14, including adding a roundabout, signal, or all-way stop control at one or both intersections. Based on the operational analysis in this study as well as consideration of other transportation facilities along SR-14, the following potential improvements are presented for consideration to reduce congestion, improve connectivity, and enhance mobility along SR-14. The construction costs included below are planning-level estimates intended to provide only a magnitude of scale and do not include costs for design, engineering, or right-of-way acquisition.

Potential improvements that could improve traffic operations along SR-14 include:

- **Upgrade traffic control at the SR-14/Oak Street intersection** – The existing conditions analysis indicates the SR-14/Oak Street intersection experiences long delays for southbound through and left turn movements on Oak Street at SR-14. With the increase in traffic volumes in the future (2037), the intersection would experience even higher delays for all Oak Street movements onto or across SR-14. The Future Build (2037) analysis indicates that either a signal (as analyzed in Concepts 14 B1 and 14 B2) or a roundabout (as analyzed in Concepts 14 A1 and 14 A2) at this

intersection would substantially decrease delays. The approximate cost of these types of improvements would be \$250,000 to \$500,000.

- **Partially or fully restrict access on Maple Street south of SR-14**
 - The Future Build (2037) analysis indicates that the SR-14/Maple Street intersection would considerably benefit by partially restricting traffic on Maple Street, and thereby, preventing the use of Maple Street by Bingen Point Business Park tenants with the installation of a barrier gate immediately north of Marina Way (as analyzed in Concepts 14 A2 and 14 B2). This partial restriction on Maple Street would require vehicles originating from or destined to locations on or south of Marina Way to use the new SR-14/Elm Street roundabout. This route change reduces the volume of vehicles traveling on Maple Street, which would decrease delays at the SR-14/Maple Street intersection. The approximate cost of this improvement would be \$5,000.
 - Another improvement that would partially restrict access to Maple Street would be the installation of barrier in the center median of SR-14 between Oak Street and Elm Street. Turning movements would be limited to right-in/right-out turning movements, which would require drivers to use other routes via Oak Street or Elm Street to make left turns.
 - Full restriction at Maple Street would involve closing the south leg of the intersection. Maple Street would be closed between SR-14 and Depot Street, which would require drivers to use other routes such as Oak Street or Elm Street to access the Bingen Point Business Park.
- **Revise and update SR-14 and Hood River Bridge intersection signal timing** – The existing conditions analysis indicates that vehicles coming off the Hood River Bridge face lengthy delays to turn onto SR-14 at the signalized SR-14/Hood River Bridge intersection. To address the current delay at this intersection, a signal phasing revision was tested as a potential mitigation measure that introduces an overlap phase for the northbound-to-eastbound right turn movement. This right turn protected phase would run concurrently with the westbound-to-southbound left turn movement from SR-14 to the Hood River Bridge and provide additional approach capacity for northbound movements. The findings of the signal phasing mitigation test show that overall average intersection delays could be reduced to approximately 42 seconds per vehicle (LOS D) based on the current capacity of the right turn lane. The approximate cost of this improvement would be \$20,000.
- **Add a rectangular rapid flashing beacon (RRFB) at SR-14 and Alder Street crosswalk** –An RRFB at the SR-14/Alder Street crosswalk is recommended to enable the pedestrians to cross SR-14 safely. In addition to improving pedestrian safety, use of this facility could occasionally introduce gaps in SR-14 traffic when pedestrians cross the highway that in turn enable turning and cross movements at Walnut Street (one block west) and Ash Street (one block east) to occur. The approximate cost of this improvement would be \$30,000.
- **Improve striping and install a radar speed sign at the SR-14/SR-141 Alt intersection** – Vehicles currently travel higher than the posted speed limit within this portion of the study area. In

addition, the steep cliff to the east of the intersection impedes sight visibility for vehicles turning from SR-141 Alt onto SR-14. Both speed and limited sight visibility pose safety concerns. Adding an eastbound left turn pocket through striping and installing a westbound radar speed sign at the SR-14/SR-141 Alt intersection could improve safety. The approximate cost of this improvement would be \$25,000.

- **Add radar speed signs on SR-14 entering town** – Radar speed signs would help reduce speeds through the Bingen downtown area, thereby creating a safer environment for vehicles, pedestrians and bicyclists. The approximate cost of this improvement would be \$20,000.

In the future, the SR-14 corridor could also benefit by implementing the following higher cost improvements:

- **Create downtown boulevard (complete street)** – Repurposing the existing right-of-way could have a calming effect on driving behavior as well as reallocate space for protected turns, which increases mobility and safety. Specific elements of a downtown boulevard could include:
 - Reconfigure angled parking to parallel parking to reallocate space to a median (some loss of on-street parking could result)
 - Construct center left turn lane through downtown so turning vehicles would be in protected lanes and through traffic flow could improve
 - Restrict SR-14 driveways to right in/right out to improve traffic flow and safety
 - Upgrade traffic control, such as adding signals or roundabouts, at additional intersections
 - Add streetscape/landscaping treatments to promote slower speeds, encourage driver awareness of being in a downtown area where more vehicle movements and pedestrian and bicycle traffic may be present, and buffer sidewalks to enhance pedestrian circulation.
- **Widen SR-14 for additional through lane(s)** – Acquire property to widen the roadway right of way so that one or more through lanes could be added on SR-14. Additional through lanes would increase roadway capacity to alleviate congestion, but may not be desirable in terms of encouraging slow travel speeds, pedestrian and bicycle travel, private property acquisition, or meeting other downtown goals by the City of Bingen.
- **Realign Maple Street to Oak Street south of SR-14 or Close Maple Street between SR-14 and Depot Street** – By realigning these two streets, north-south and turning movements could be consolidated in one intersection. Traffic flow on SR-14 could improve by replacing two closely spaced intersections with a single intersection.

In addition, the study also identified the following pedestrian and bicycle improvements:

- **Complete sidewalk along eastbound SR-14 to new SR-14/Elm Street roundabout** – Sidewalk along SR-14 eastbound begins just west of the SR-14/Hood River Bridge intersection and continues until the SR-14/Maple Street intersection. Pedestrians wishing to continue walking on

a sidewalk would need to cross SR-14 at Maple Street and continue walking east along the north side of SR-14. The proposed SR-14/Elm Street roundabout would include crosswalks and continued sidewalks south on Elm Street. Adding sidewalk along eastbound SR-14 from Maple Street to the new SR-14/Elm Street roundabout (3 blocks) would improve connectivity and encourage safe pedestrian circulation in the study area. The approximate cost of this improvement would be \$125,000.

- **Construct multi-use path through town parallel to SR-14** – To enhance pedestrian and bicycle connectivity and experience in the study area, one consideration would be to locate a parallel multi-use path further away from SR-14.

9 REFERENCES

Amtrak. 2017. Operating Plan.

<https://www.amtrak.com/services/contentService.iblegacy.routes.empire-builder.html>. Website accessed in 2017.

City of Bingen. 2017. Email from City providing on-street parking data.

Federal Highway Administration (FHWA). 2016. Freight Analysis Framework 4.2.

https://ops.fhwa.dot.gov/freight/freight_analysis/faf/

Google Earth Pro. 2018. Aerial imagery of study area.

Gorge Translink. 2018. Mt. Adams Transportation Services (MATS). <http://gorgetranslink.com/transit-klickitat.html>

Gorge Translink. 2018. Passenger Guide/Public Transportation Schedule: White Salmon & Bingen WA to Hood River, OR <http://gorgetranslink.com/documents/WhiteSalmonBrochure.pdf>

Sightline Institute. 2017. 154,000 Barrels of Crude-by-Rail Each Day to Puget Sound.

<https://www.sightline.org/2017/01/31/154000-barrels-of-crude-by-rail-each-day-to-puget-sound/>

Transportation Research Board. 2000. Highway Capacity Manual 2000.

https://snavarro.files.wordpress.com/2008/08/highway_capacital_manual.pdf

Transportation Research Board. 2010. Highway Capacity Manual 2010 <http://hcm.trb.org/?qr=1>

Washington State Department of Ecology (2018). Crude Oil Movement by Rail and Pipeline Quarterly Report: October 1, 2017 through December 31, 2017.

<https://fortress.wa.gov/ecy/publications/documents/1808004.pdf>

Washington State Department of Transportation (WSDOT). 2010. Level of Service Standards for Washington State Highways. <http://www.wsdot.wa.gov/NR/rdonlyres/6AF72388-2455-47B9-B72D-2BE9A89A0E19/0/LOSStandardsforWAHwys.pdf>

Washington State Department of Transportation (WSDOT). 2015. 2015 Washington State Annual Collision Summary, Page 10.

https://www.wsdot.wa.gov/mapsdata/crash/pdf/2015_Annual_Collision_Summary.pdf. Website accessed on 12/05/2018.

Washington State Department of Transportation (WSDOT). 2016. 2008 to 2016 Annual Traffic Report.

<http://www.wsdot.wa.gov/mapsdata/travel/annualtrafficreport.htm>. Website accessed in 2017.

Washington State Department of Transportation (WSDOT). 2018. WSDOT Functional Classification Map.

<http://www.wsdot.wa.gov/data/tools/geoportal/?config=FunctionalClass>

Washington State Office of Financial Management (OFM). 2017. State of Washington Forecast of the

State Population: November 2016 Forecast. <https://www.ofm.wa.gov/washington-data-research/population-demographics/population-forecasts-and-projections/state-population-forecast>.

Website accessed 11/2017.

APPENDIX A – EXISTING AND FUTURE CONDITIONS FOR TRUCKS ON SR-14



MEMO

TO: Dale Robins, Southwest Washington Regional Transportation Council
FROM: Bridget Wieghart, WSP
SUBJECT: SR-14 Bingen/White Salmon Circulation Study: Existing and Future Conditions for Trucks on SR-14
DATE: Revised December 6, 2018

EXISTING CONDITIONS FOR TRUCKS ON SR-14

TRUCK VOLUMES

Traffic demand in the study area consists of a high proportion of trucks. Traffic counts were taken at several points in and around Bingen in the fall of 2016. Based on these counts, total truck annual average daily traffic (AADT) ranges from approximately 800 to 1,300 on SR-14 in the study area when both east and westbound directions are combined. As a proportion of total traffic along this stretch of SR-14, single unit (2 to 4-axle) trucks represent 9 to 20%, double unit trucks represent 2 to 5% and triple unit truck represent between 0.5% and 1%. In total, trucks on SR-14 in the study area comprise 12 to-25%of overall traffic demand.

Other routes in the study area also have a high proportion of trucks. Trucks represent approximately 15 to 20% of daily traffic on SR-141 Alternative just north of SR-14, 7 to 9% on Oak Street (SR 141) north of SR-14 and 12 to 15% on Walnut Street between SR-14 and Depot Street. Stakeholders emphasized that SDS Lumber is a major origin/destination for trucks in the study area; the primary access point for SDS Lumber being located on Maple Street.

STAKEHOLDERS OBSERVATIONS ABOUT FREIGHT

A number of businesses depend on trucks to receive materials and deliver end products. SDS Lumber is the largest local generator of heavy trucks in the study corridor with an average of 50 to 75 trucks per day entering and exiting their facility near SR-14. The number of trucks can increase to over 150 trucks per day during busy peak processing periods. Mountain logging, Underwood Fruit, Riley Materials, Dickey Farms and Insitu



also have significant truck components to their businesses. Businesses noted that they anticipate growth, which will affect both employee and truck traffic.

Stakeholders interviewed for this study (see Appendix B), including owners of the businesses mentioned above and a community member, note that traffic has increased considerably in recent years and the area now experiences a rush hour during commute times. Several stakeholders expressed concern about the ability to receive shipments in a timely manner as congestion grows.

Other concerns included the difficulty of maneuvering large trucks on the Hood River Bridge and the need for more turn lanes on SR-14 to allow trucks to exit SR-14 without affecting through traffic. They also stressed the importance of maintaining all access points onto SR-14 for business and emergency use. Some participants believe that too many heavy trucks use SR-14 as a through route and that some of these should be on I-84. Overweight trucks cannot use the Hood River Bridge or the downstream Bridge of the Gods and thus must remain on SR-14 for longer stretches.

COMMODITY FLOWS IN THE STUDY AREA

The Freight Analysis Framework (FAF) synthesizes current commodity flows throughout the country for all modes of transportation. A recent update based on a 2012 Commodity Flow Survey provides a comprehensive representation of freight movement for the base year 2012 and allows projections up to 2045 in five year intervals.¹ The regional data provided by FAF was disaggregated to the county level. Based on FAF 4.2, an annual summary of truck flows in and out of Klickitat County (attached) was prepared. In total, nearly 2 million commodity tons traveled into and out of the county in 2012. Top commodity flows in and out of the county are also summarized on a separate table on the attachment. As shown, the top five commodities originating from the county in terms of tonnage include “other” agricultural products, gravel, logs, wood products and waste scrap.

The top five commodities destined into the county are logs, waste scrap, cereal grains, fertilizers and gravel.

BALANCE OF TRUCK TRAFFIC BETWEEN I-84 AND SR-14

The State of Oregon currently charges a weight-mile tax on vehicles with a gross weight of over 26,000 pounds (13 tons). Tax rates per mile vary according to the gross weight of the vehicle. Oregon does not collect diesel taxes on heavy trucks while Washington does collect heavy vehicle diesel taxes. There has been a great deal of concern over time about the impact of trucks on SR-14 and the perception that some of those trucks are diverting from I-84 to SR-14 in order to avoid the weight mile tax. Depending on the specific weight of the truck, origin and destination, and contracting arrangement, it might be less

¹ <http://faf.ornl.gov/fafweb/Default.aspx>



expensive for a trucker to gas up in Oregon (where there is no diesel tax) and travel on SR-14 for a portion of the trip that would otherwise be on I-84.²

In 1997, as part of the SR-14 Corridor Management Plan, WSDOT with RTC conducted a license plate survey of trucks along SR-14 between the Bonneville Dam and US 97. Truck traffic on the Bridge of the Gods, Hood River Bridge, and The Dalles Bridge was surveyed. Information from weigh stations and truck inspection facilities in the parallel section on I-84 was also reviewed. Based on the movements examined over a two-day period, it appeared that most of the truck traffic on SR-14 originated or terminated in the survey area. The amount of through traffic appeared consistent between the two days. However, based on differences in bridge traffic, it was estimated that 3 to 4% of the traffic might be avoiding the Oregon weight mile tax by crossing the river northbound on the Bridge of the Gods and southbound at The Dalles Bridge. The highest truck volumes were in the White Salmon/Bingen area.

Feedback from freight planning specialists with detailed knowledge of weight mile tax calculation and travel analysis in Oregon was solicited regarding this specific issue. ECONorthwest, which calculates the weight mile tax rates for Oregon, estimates overall evasion of the weight-mile tax to be in the order of 5% based on weight transport. This amount is consistent with the 1997 license plate survey.³ The findings of these discussions indicate that the diversion between I-84 and SR-14 is likely to be limited for longer trips and larger trucking companies, where truckers are salaried, due to the slower travel on SR-14 than I-84. In addition, unless the trucker evades fuel taxes in Washington, traveling on SR-14 is not free.⁴

Using FHWA methodology and free flow travel speeds, an analysis of travel times shows that travel times on SR-14 from I-82 to I-5 are approximately 12% greater than on I-84. Based on this analysis, the majority of truck traffic on SR-14 either originates from, or has a destination in, Washington State, which is supported by the 1997 study. This hypothesis seems to be supported by the truck volumes which are at least five times as heavy on I-84 in this area versus SR-14. Trucks also represent a higher proportion of total traffic on I-84 compared to SR-14.

For the segment of SR-14 between I-5 and US 97, particularly between the Bonneville Dam and U 97, the time to cross bridges back and forth and the additional risk of delays on narrow, two-lane portions of SR-14 (in some segments), diverting to and from I-84 would likely not be worth the travel time cost for the majority of the through traffic. However, for shorter, repeated trips by independent truckers, it might be worthwhile.⁵

² SR 14 Corridor Management Plan, Truck Movement Report

³ Carl Batten, Project Director/Partner, ECONorthwest, March 8, 2017 email.

⁴ Ibid and Becky Knudson, Senior Transportation Economist, ODOT, March 8, 2017 telephone conversation and Rick Donnelly, Senior Transport Modeler, WSP/PB (responsible for the freight component of the Oregon Statewide Improvement Model), March 10, 2017 email.

⁵ SR-14 Corridor Management Plan



In summary, it is likely that some truck trips with an origin or destination within Washington may travel on SR-14 longer than necessary in order to minimize paying the weight mile tax in Oregon. Independent truckers, in particular, who pay the fee themselves, might find it cost beneficial to divert to SR-14 for a portion of their trip, if they have not negotiated the weight mile fee into their contract. A previous study estimated this potential diversion at minimum of 3 to 4%. With the volume of traffic on I-84, even this rate of diversion could result in an impact to SR-14. A comprehensive origin and destination study and comparison of relative travel times and costs between the two facilities would be needed in order to confirm the specific amount of diversion that takes place today.

FUTURE CONDITIONS FOR TRUCKS ON SR-14

TRUCK VOLUMES

An estimate of future truck volumes was developed based on commodity flow data provided by the FHWA's FAF⁶ database. At the time of this estimation, the most recent version available was FAF 4.2, which has been used consistently in this work. The resolution of the FAF data with 132 zones within the U.S. is too coarse to analyze freight flows in any given study area. Therefore, a method was developed to disaggregate freight flows from 132 FAF zones to 3,241 U.S. counties and to trucks. This approach is further detailed later in this memo (see Truck Traffic Estimation SR-14).

The annual growth rate of truck traffic (based on an assignment of FAF 4.2 commodity flows; see explanation of methodology later in this appendix) during the study period is anticipated to be approximately 1.9%. This is similar to the rate of traffic increase overall, which is expected to be 2.1% annually. Thus, the proportion of trucks is expected to remain nearly the same but decline very slightly over time.

ANTICIPATED CHANGES IN LOCAL TRUCK ACTIVITY

The existing conditions analysis identified a number of businesses that depend on trucks to receive materials and deliver end products. Most businesses interviewed noted that they anticipate growth, which will affect both employee and truck traffic in the future. Several stakeholders expressed concern about the ability to receive shipments in a timely manner as congestion grows. Analysis of future traffic conditions shows that congestion will increase during rush hour periods, supporting stakeholders' concerns.

In addition, planned development of 30 acres of Bingen Point Business Park, 5 acres of private property and additional 24 acres for Mill site would occur in the next 15 to 25 years. For the purposes of this study, it is assumed that 60% (35 acres) of the forecasted development would occur in the next 20 years. Thus, local traffic for both cars

⁶ FHWA Freight Analysis Framework (FAF)
https://ops.fhwa.dot.gov/freight/freight_analysis/faf/, accessed 2016.



and trucks would increase, though the proportion of trucks into and out of Bingen Point is expected to be lower than on SR-14.

COMMODITY FLOWS IN THE STUDY AREA

Based on FAF 4.2, annual summaries of truck flows in and out of Klickitat County for the years 2012 and 2045 (attached) were prepared. In total, nearly two million commodity tons traveled into and out of the county in 2012. Total commodities traveling in and out of the county by truck are expected to increase by more than 50 percent and exceed three million tons by 2045.

Top commodity flows in and out of the county are also summarized on a separate table on the attachment. As shown, the top five commodities originating from or destined to the county in terms of tonnage today include logs, other agricultural products, wood products, gravel and waste/scrap. In 2045, the top five commodities into or out of the county are expected to be the same. By 2045, newsprint/paper is expected to drop out of the top ten and be replaced by miscellaneous manufactured products. Gasoline is expected to drop out of the top 13 and be replaced by natural sands.

BALANCE OF TRUCK TRAFFIC BETWEEN I-84 AND SR-14

Currently, I-84 carries approximately five times the volume of trucks as SR-14. In terms of commodity flows, assignment of the disaggregated FAF forecast to the simplified network indicates that the rate of growth of trucks will be similar on both sides of the river. However, there are several policy factors that might affect this projection.

Differences in the costs and travel time for trucks on SR-14 versus I-84 and the potential impact on truck traffic between the two facilities were described earlier under the existing conditions – with the Oregon weight-mile tax likely resulting in some diversion to SR-14 from I-84.

It is challenging to speculate how the balance of traffic between I-84 and SR-14 might evolve over time. Near-term technological improvements increase the probability of taxing enforcement should the states chose to do so. In addition, both Oregon and Washington are exploring shifting from gasoline-based charges to mileage-based user charges for all vehicles in the longer term. Thus, depending on policy decisions with respect to roadway pricing and enforcement mechanisms, it is quite possible that the financial incentive for trucks to divert to SR-14 will decline over time. However, differences in background traffic growth and responses to congestion between the two states could also affect travel times on the facilities, which would further confound the analysis.

In conclusion, the future balance of trucks on the facilities depends on a number of policy decisions that are beyond the scope of this study. Without more specific guidance regarding likely future policy scenarios, the analysis for this effort has assumed a split based primarily on the shortest path and leads to truck demand levels that are proportionate to existing percentages.

TRUCK TRAFFIC ESTIMATION METHODOLOGY FOR SR-14

To capture a sketch forecast of truck traffic on a segment of Washington SR-14, an estimation approach was developed. It uses trucks trips that flow across the entire continental U.S. for the years 2012 and 2045. Truck trips are generated based on commodity flow data provided by the FHWA’s FAF⁷ database. At the time of this estimation, the most recent version available was FAF 4.2, which has been used consistently in this work. The resolution of the FAF data with 132 zones within the U.S. is too coarse to analyze freight flows in any given state or study area. Therefore, a method was developed to disaggregate freight flows from 123 FAF zones to 3,241 U.S. counties. This approach also converted commodities into trucks.

An overview of the truck model design is shown in Figure A.1. First, the FAF data are disaggregated to counties across the entire U.S. using 11 employment types and input/output coefficients (also called make/use coefficients). These data are derived from Census Business Patterns (CBP) and Bureau of Labor Statistics (BLS) data. Then, commodity flows in tons are converted into truck trips using average payload factors. Empty truck trips are added, and the total truck trips are assigned to a national highway network. This procedure was conducted for 2012 and 2045 trucks. Figure A.2 shows the truck assignment result nationally.

Figure A.1: Truck Model Flowchart

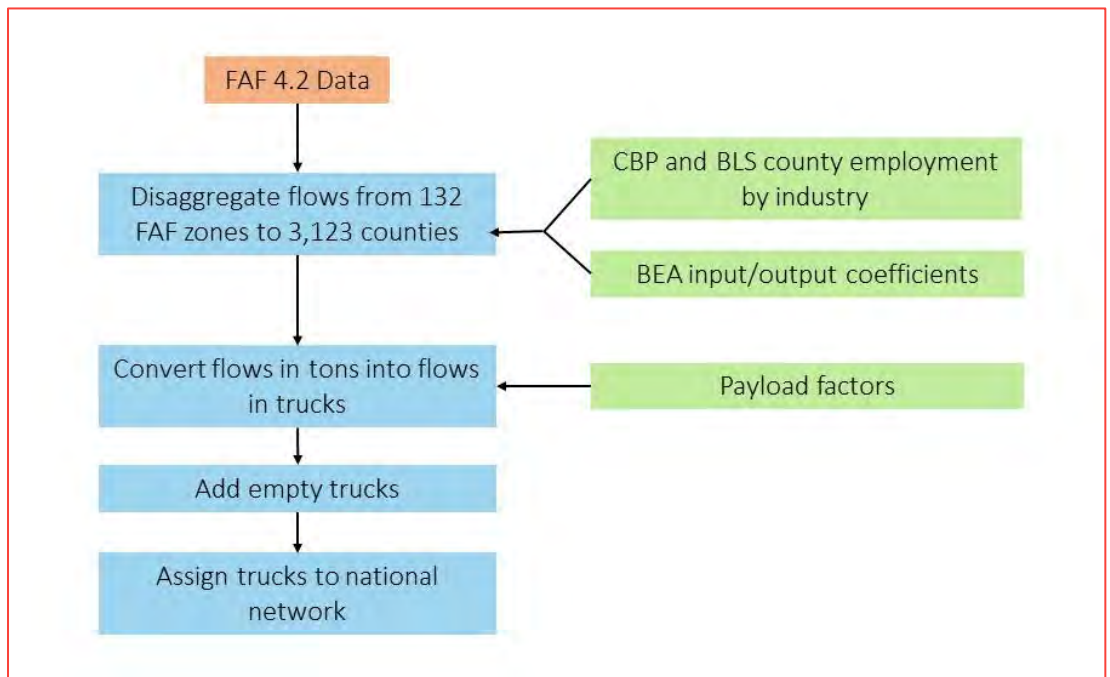

⁷ FHWA Freight Analysis Framework (FAF)

https://ops.fhwa.dot.gov/freight/freight_analysis/faf/, accessed 2016.

Figure A.2: Nationwide Assignment of Truck Flows

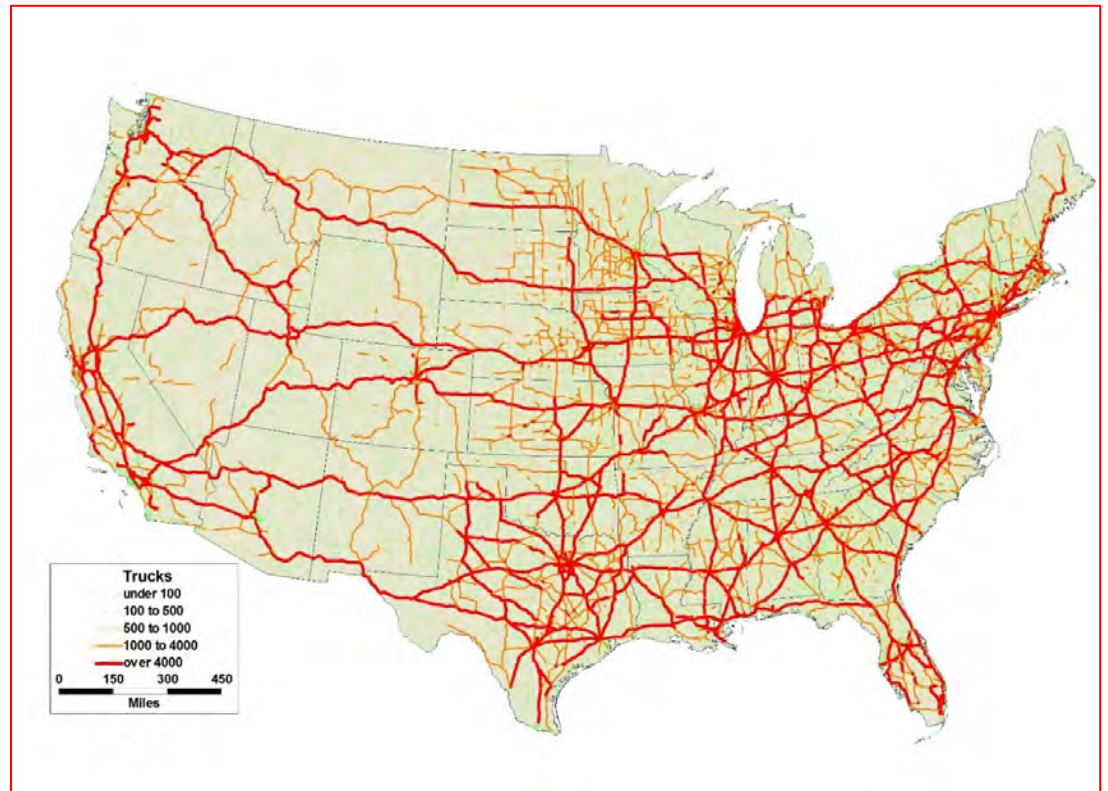

In the final step for sketch level truck estimation between 2012 and 2045, the truck trip tables are assigned across the FAF highway network which is provided by FHWA with the commodity flow data. An All-or-Nothing (AON) assignment is utilized, referencing the speed limit or posted speed. Locally obtained Truck ADT is used to verify the reasonability of the resulting truck flows.

Figure A.3: Model Network with 2012 and 2045 Daily Truck Traffic

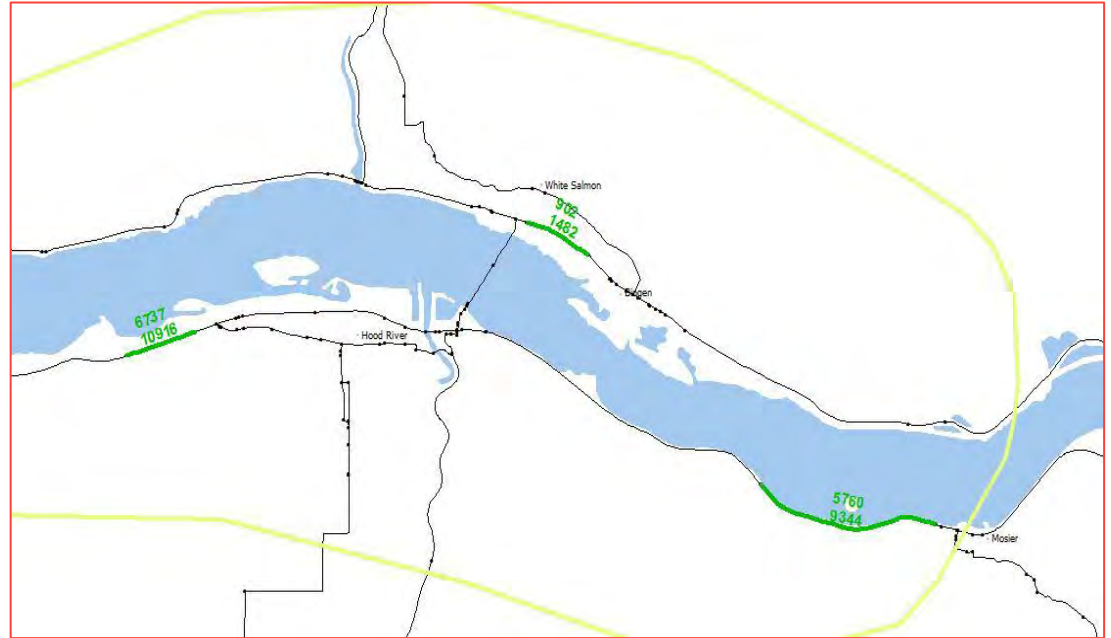

Truck Daily Traffic

Road	Observed*	2012	2045	Change	
				Trucks	%
SR-14	917	902	1482	580	64%
I-84	7500	6737	10916	4179	62%
I-84	5000	5760	9344	3584	62%

* <http://www.wsdot.wa.gov/mapsdata/tools/trafficplanningtrends.htm>

* <https://gis.odot.state.or.us/transgis/>

Klickitat County, WA - FAF 4.2 Annual Truck Commodity Flow Summaries

in annual thousands of tons

2045

SCTG*	Description	OUT	IN	SUM
1	Live animals/fish	12	0	12
2	Cereal grains	0	59	59
3	Other ag prods.	353	26	379
4	Animal feed	3	42	45
5	Meat/seafood	2	6	8
6	Milled grain prods.	3	4	7
7	Other foodstuffs	0	1	1
8	Alcoholic beverages	14	4	18
9	Tobacco prods.	0	0	0
10	Building stone	0	0	0
11	Natural sands	13	15	28
12	Gravel	211	56	267
13	Nonmetallic minerals	5	2	7
14	Metallic ores	0	4	4
15	Coal	0	3	3
16	Crude petroleum	0	0	0
17	Gasoline	0	16	16
18	Fuel oils	1	10	11
19	Coal-n.e.c.	3	8	11
20	Basic chemicals	0	0	0
21	Pharmaceuticals	0	0	0
22	Fertilizers	2	40	42
23	Chemical prods.	6	7	13
24	Plastics/rubber	7	8	15
25	Logs	514	1012	1526
26	Wood prods.	227	21	248
27	Newsprint/paper	26	9	35
28	Paper articles	2	4	6
29	Printed prods.	1	1	2
30	Textiles/leather	0	1	1
31	Nonmetal min. prods.	11	57	68
32	Base metals	11	10	21
33	Articles-base metal	2	8	10
34	Machinery	4	11	15
35	Electronics	2	5	7
36	Motorized vehicles	4	11	15
37	Transport equip.	0	1	1
38	Precision instruments	0	1	1
39	Furniture	3	4	7
40	Misc. mfg. prods.	29	19	48
41	Waste/scrap	52	135	187
43	Mixed freight	16	25	41
	Total	1539	1646	3185

2045

Top Thirteen	SCTG	Annual 000s of tons
Logs	25	1526
Other ag prods.	3	379
Gravel	12	267
Wood prods.	26	248
Waste/scrap	41	187
Nonmetal min. prods.	31	68
Cereal grains	2	59
Misc. mfg. prods.	40	48
Animal feed	4	45
Fertilizers	22	42
Mixed freight	43	41
Newsprint/paper	27	35
Natural sands	11	28
All Other		212
Check		3185

2014

Top Thirteen	Annual 000s of tons
Logs	887
Other ag prods.	272
Wood prods.	172
Gravel	154
Waste/scrap	132
Cereal grains	52
Fertilizers	38
Newsprint/paper	33
Nonmetal min. prods.	32
Animal feed	30
Mixed freight	28
Misc. mfg. prods.	26
Gasoline	25
All Other	116
Sum	1997

* Standard Category of Transported Goods

APPENDIX B – STAKEHOLDER SUMMARY MEMORANDUM



May 9, 2017

MEMORANDUM

TO: Dale Robins, Southwest Washington Regional Transportation Council

FROM: Seth Baker, EnviroIssues
Anthony Lo, WSP Parsons Brinckerhoff

RE: Stakeholder Interview Summary for SR-14 Bingen/White Salmon Circulation Study (Final)

Overview:

EnviroIssues conducted nine interviews with 11 participants who rely on SR-14 within the Bingen/White Salmon circulation study area to understand key transportation and economic development interests as well as critical pathways for emergency response. Interview questions focused on deficiencies in the local transportation system and ideas to address deficiencies. The number of people who provided input is a small, though highly informed, portion of the overall population interested in and affected by the travel effects and transportation decisions in the study area. The qualitative summary should not be equated with a statistically representative survey or quantitative research, but provides important and useful information to consider for future planning.

This memorandum includes a summary of interview responses. Interview statements may not reflect actual conditions in all cases, but represent the understanding or opinions of interview participants.

Interview questions framing each discussion are included at the end of this document.

Interview Objectives:

- Collect information related to SR-14 use or proximity of various stakeholders in the circulation study area
- Assess the range of existing and future transportation and economic development interests within the circulation study area
- Identify transportation challenges and possible solutions
- Identify critical pathways for emergency responders

Participants:

EnviroIssues contacted interview participants by phone to schedule interviews using a stakeholder list provided by the Southwest Washington Regional Transportation Council. Eight interviews were conducted in person at locations in Bingen or White Salmon on April 5 and April 6, 2017. One interview was conducted by phone on April 20, 2017. Interview participants are listed in Table 1.

Table 1. List of Interview Participants

Affiliation	Participants
Underwood Fruit	Ed Ing, Superintendent Brad Pickering, Assistant Superintendent
Mountain Logging / DJ's Repair & Rental	David Clark, President
Dickey Farms	Stan Dickey, President
Rapid Ready Mix / Riley Materials	Izak Riley, General Manager
Bridge Mart	Jim Kim, Manager
Bingen-White Salmon Police Department	Tracy Wyckoff, Chief
Insitu	Tammy Kaufman, Community Relations Coordinator Jenny Taylor, Infrastructure and Real Estate Director
Community Member	Laura Mann
SDS Lumber	Jason Spadero, President

A map of interview participant locations and the locations of key intersections included in the circulation study are shown in Figure 1. Some participants own additional facilities at locations not labeled on the map.

Figure 1. Map of Interview Participants and Key Intersections

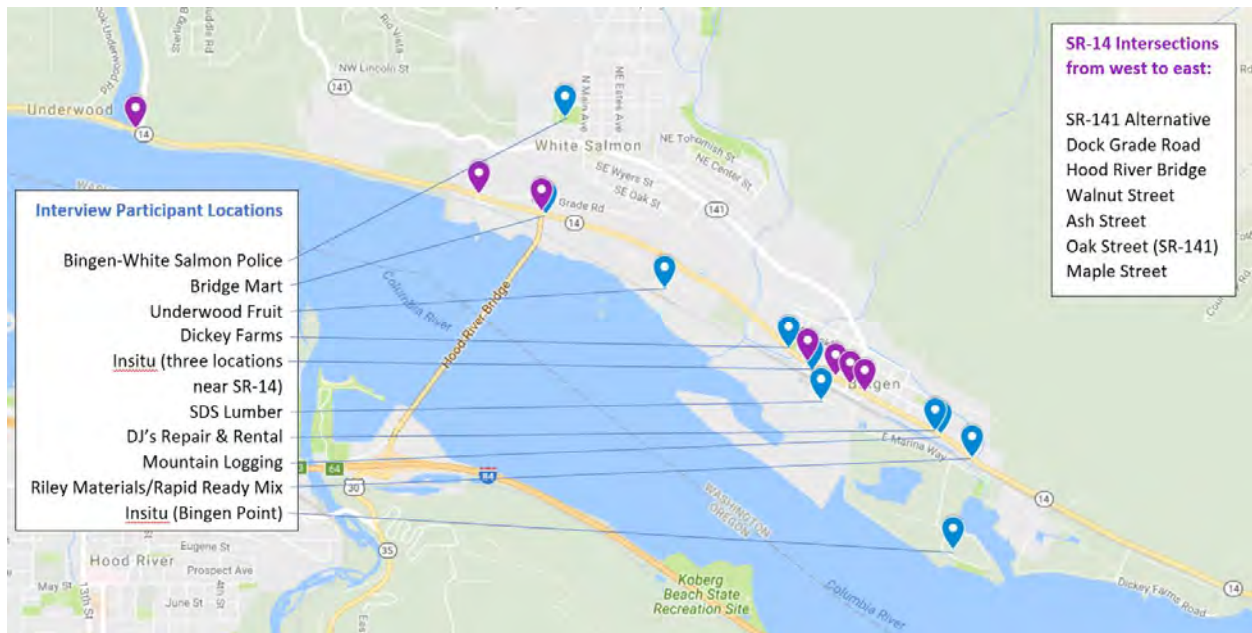

Findings:

Overall, interview responses focused on the following topics.

Congestion: Multiple participants described traffic on SR-14 as “constant” and noted that the road is much busier now than in years past when there were few cars on the road. The circulation study area now experiences a rush hour during commuting times that didn’t exist before, and participants said improvements may be needed at major intersections (Hood River Bridge, SR-141/Oak Street and Maple Street) to enhance traffic flow and safety. Several participants said there are too many heavy trucks passing through Bingen that should be using I-84 instead and WSDOT should work with ODOT to find solutions that keep these trucks off SR-14. Participants also said SR-14 cannot accommodate all the traffic that results when ODOT closes I-84 and said there needs to be a better plan in place to avoid congestion and road damage on SR-14 during these events.

Business health: Business participants discussed the connection between SR-14 and the health of their business operations. Several businesses in the circulation study area depend on large numbers of truck shipments to receive materials and distribute products. Other businesses with a retail component depend on SR-14 for visibility to attract customers. Participants said the congestion within the circulation study area was tolerable for small commuter vehicles, but is affecting the ability of large trucks to complete local shipments efficiently. The health of these businesses may decline if truck shipments cannot flow in an efficient and timely manner. Participants that depend on heavy trucks said ongoing maintenance of SR-14 is important to help keep their trucks in good condition and reduce truck damage costs and down time. Participants said it would be helpful to have SR-14 improvements that assist trucks trying to turn on and off SR-14, such as additional left turn lanes. Participants also commented on how traffic congestion affects their employees’ ability to travel quickly between facilities during the work day and arrive at meetings on time.

Safety: Participants described traffic as a safety hazard within the circulation study area, particularly affecting drivers trying to enter SR-14 and drivers on SR-14 trying to turn left across traffic. Participants also said traffic is a safety hazard for pedestrians and solutions were needed to slow traffic through town and make crosswalks more visible. Participants said WSDOT has made safety improvements in the past by reducing speed limits, adding left turn lanes and marking crosswalks, but safety issues have not been fully addressed.

Detailed responses to interview questions are summarized below.

Business growth expectations

- Four of the seven participating businesses reported plans to expand operations within the circulation study area in the near future:
 - Underwood Fruit has purchased adjacent property to the east of their location on SR-14. They could develop the property within the next 3 – 5 years. Truck flow and employee parking has been a challenge for growth.
 - Riley Materials is increasing their fleet of trucks to keep up with demand for construction materials. They expect to double in size within the next 2 – 5 years.
 - Insitu is consolidating some of their operations into their expanding Bingen facilities and they expect their number of employees to continue to grow. Their business markets have been growing every year and they expect to continue to grow with demand.

- SDS is planning capital improvements and expansions that could increase lumber production by 30 percent. The number of large trucks entering and exiting SDS Lumber's facilities is expected to increase. The number of employees will remain about the same.
- SDS Lumber has the largest use of heavy trucks of local businesses within the study corridor, with an average of 50-75 trucks per day entering and exiting facilities from SR-14 and over 150 trucks per day during busy times. Mountain Logging, Underwood Fruit, Riley Materials, Dickey Farms and Insitu also have significant truck components to their businesses.
- The productivity of some businesses is linked to increasing trends in the region such as population growth, construction, tourism and recreation.
- Some participants have been negatively affected by regulatory changes or said there was too much uncertainty around regulation to be able to forecast their growth potential. These businesses are trying to adapt their business models to new circumstances.
- Some local businesses are seasonal in nature and become more or less busy depending on the weather.

Observations of traffic trends on SR-14

- Traffic has noticeably increased within the circulation study area over the last five years and participants expect traffic to become increasingly congested in the future. Participants characterized traffic as "constant" and said they often need to wait for an opening in traffic to enter SR-14, whereas there was little to no wait in previous years. Several participants said they noticed an increase in the number of heavy trucks passing through Bingen.
- Participants attributed increases in traffic congestion to increases in the number of people living and recreating in the Columbia River Gorge and lower trucking fees on SR-14 compared to I-84.
- Participants have observed rush hour traffic congestion that did not exist a few years ago. Traffic now peaks on weekdays between 7 – 9 a.m., 4 – 6 p.m. and during the lunch hour. One participant said traffic congestion is affected by school bus schedules shuttling students in the afternoon.
- Participants noted that there are vacant buildings in downtown Bingen that could house large employers in the future and increase the number of people commuting to Bingen.
- It has become more difficult to turn onto SR-14 from roadside businesses due to the number of vehicles on the road at any given time. Similarly, it is difficult to make unprotected left turns to exit SR-14. This is especially difficult for long trucks or slow-moving vehicles.
- Traffic patterns on SR-14 changed when Dock Grade Road became a one-way street to enter White Salmon. People who commute out of White Salmon to SR-14 now only have one route option (SR-141) instead of two.
- Steuben Street through Bingen has become busier with more pedestrian traffic as more offices and restaurants have opened along the street.
- Participants who have lived in the area for a long time have noticed a change in driving culture. Many drivers seem less patient with slow moving trucks or farm equipment on SR-14.
- When ODOT closes I-84, its traffic is moved to SR-14. SR-14 is not able to accommodate the additional traffic from I-84 and experiences debilitating congestion. These events do noticeable damage to the SR-14 road surface. Participants said the frequency of I-84 closures seems to have increased in recent years.

Importance of SR-14 to businesses

- Participants characterized SR-14 as “critical,” “essential” and “very important” to their business operations. Some participants said they would go out of business if SR-14 was closed to traffic for more than a short period of time.
- Businesses depend on SR-14 to get employees to work, receive shipments, distribute products, and/or intake customers. It was important to several participants that their retail businesses remain visible on SR-14 so potential customers know about their business.
- The growth potential of many businesses depends on the number of truck shipments that come in and out from SR-14 each day. These businesses will not be able to grow in Bingen if traffic congestion limits the number of local truck shipments. Some shipments are very time sensitive.
- Businesses that depend on heavy trucks said it was important to maintain or improve their access to SR-14 to facilitate truck flow and maintain evacuation routes and emergency vehicle access. SDS Lumber and other participants said it was important to maintain all of SDS Lumber’s facility access points on Maple Street to facilitate the growing number of large trucks entering and exiting SDS Lumber facilities.
- Trucks are sometimes backed up on SR-14 waiting for an opening in traffic so they can turn into a business. This backup can affect traffic for other SR-14 users.
- Several participants have multiple business locations, properties, offices, or storage facilities and use SR-14 to travel to these locations during the work day. Sometimes congestion on SR-14 during the day affects employees’ ability to travel between these facilities in a timely manner, which has a negative effect on business operations.
- Several participants mentioned the importance of Maple Street as the primary SR-14 access point for SDS Lumber trucks as well as truck and employee traffic for businesses located at Bingen Point. Maple Street is also an important evacuation route and access point for emergency vehicles.
- Participants said they are wary of the negative effect traffic congestion can have on their employees’ job satisfaction.
- Commutes are a factor considered by prospective employees. Insitu sometimes has trouble recruiting new employees who think SR-14 is too dangerous or unpredictable to commute on.

Importance of SR-14 to community members

- Participants described SR-14 as “vital” and “the lifeblood of the community” for Bingen and White Salmon. Anyone traveling through Bingen or to White Salmon will need to use SR-14 eventually.
- Community members depend on SR-14 for daily tasks like going to work or going to the store.
- SR-14 connects communities along the Columbia River and provides access to recreation sites.
- When traffic is congested on SR-14 in Bingen, some drivers try to take side streets through town. This has a negative effect on people who live and work on side streets.
- Bingen does not have much space to increase local housing, but the number of jobs in Bingen will increase due to growth at the Bingen Point Business Park. SR-14 will continue to be an essential corridor to bring growing numbers of employees from outside of Bingen to the business park.

Critical pathways for emergency responders

- SR-14 and SR-141 are critical pathways for emergency responders in Bingen and White Salmon. Emergency responders depend on these roadways to get to their destinations quickly.

Current problems on SR-14

Participants reported the following problems on SR-14.

- Congestion at the Hood River Bridge is a major issue, especially when turning left off of SR-14 onto the bridge. Congestion has improved since a traffic signal was installed, but wait times for left-turns seem too long. Some cars pass through the intersection and turn around so they can make a right-turn onto the bridge more quickly.
- If a power outage causes the traffic signal at the Hood River Bridge to go out, duty often falls on Bingen-White Salmon police to direct traffic at the intersection. The traffic signal is owned and operated by Washington State and should be supported by state resources.
- Traffic is too busy during the work day to haul farm equipment on SR-14. Dickey Farms now waits to haul farm equipment on weekends, whereas they could haul equipment as needed in previous years.
- Very heavy trucks cannot use the Hood River Bridge or the Bridge of the Gods. This forces many trucks to pass through Bingen on their way to The Dalles Bridge or the Glenn Jackson Bridge.
- Cars travel too quickly and too frequently for large trucks to be able to pull onto SR-14 safely. There have been multiple collisions at the intersection of SR-141 Alternative, which resulted in WSDOT reducing the speed limit and adding caution signs. Participants also called the SR-141 Alternative intersection a “blind” intersection with line of sight issues.
- SR-14 is sometimes closed by rock falls and downed trees at the west end of the circulation study area near the intersection with SR-141 Alternative.
- Cars get rear-ended as they slow on SR-14 to turn into a business.
- The intersection of SR-14 and SR-141 has become more congested since Dock Grade Road became a one-way street. It is particularly congested in the evening when people are leaving work in White Salmon to access SR-14. Trucks will wait for long periods of time to turn left onto SR-141. Some drivers get tired of waiting and make unsafe turns.
- Large trucks sometimes get stuck going up Dock Grade Road from SR-14. Large trucks are not supposed to use Dock Grade Road, but GPS systems often lead them there.
- The intersection of SR-14 and Maple Street becomes congested during rush hour as commuters enter and exit the Bingen Point Business Park. Congestion is exacerbated by frequent train crossings at Maple Street. The intersection is also heavily used by trucks accessing SDS lumber.
- Pedestrian and crosswalk visibility is a safety concern on SR-14. The crosswalks are fading and pedestrians are difficult to see at night or in the rain. The bulb outs that were installed seem to give pedestrians a false sense of safety as they enter the street. The Walnut Street crosswalk is a particular concern for Insitu as their employees need to cross SR-14 at this location to walk between their office and parking lot.
- There needs to be a continuous trail for walking or cycling between downtown Bingen and workplaces at the Bingen Point Business Park.
- Congestion is a time cost that could be spent doing other things.
- Bingen has a small tax base and supports a very busy transportation corridor. Bingen needs support of outside resources to keep SR-14 maintained.

Improvements to SR-14 that would better serve business needs

Participants offered the following suggestions:

- A grade-separated railroad crossing accessing Bingen Point Business Park could help relieve rush hour traffic at Maple Street. However, multiple participants did not want SDS Lumber to lose any access points to Maple Street as a result of building a grade-separated railroad crossing.
- A traffic signal may help ease congestion at the intersection of SR-14 and Maple Street.
- A traffic signal may be needed at the intersection of SR-14 and SR-141 to help drivers make left turns safely and help traffic backups on SR-141 in the evening.
- Businesses sometimes get backed up with many truck deliveries. It would be helpful to have a safe place where large trucks could pull off of SR-14 to wait for their turn to drop off or pick up shipments.
- More center turning lanes on SR-14 would help reduce congestion, reduce rear-end collisions and make it easier to turn left into businesses.
- WSDOT should keep up on road maintenance to make sure SR-14 remains open and reduce damage to trucks. Chip sealing does not seem to be effective.
- WSDOT should maintain the entire right-of-way of SR-14. In some places, the driving surface has been repaved multiple times, but the road shoulder has not been maintained. This creates a height difference resulting in steep ditches in road shoulders that damage vehicles.

Improvements to SR-14 that would better serve community needs

Participants offered the following suggestions:

- The Hood River Bridge traffic signal needs to be adjusted to allow more left-turning vehicles to pass per green light.
- Community members would like to have a continuous pedestrian/bicycle path that connects communities along SR-14 and provide more transportation options. Specific to the circulation study area, it would be helpful to have a continuous path that connects the park and ride near the Hood River Bridge to workplaces at Bingen Point Business Park.
- There needs to be a long-term solution to the number of rock slides and tree falls on SR-14, particularly between the Hood River Bridge and the White Salmon River.
- There needs to be better signage and/or enforcement of no parking areas along SR-14. Tourists often stop on SR-14 in unsafe areas to take photos.
- Crosswalks need to be made safer and more visible with bright markings and flashing lights. The current crosswalk markings fade quickly. Participants reported that WSDOT has indicated there are limits on the types of visibility tools that can be used on SR-14 because it is a highway and not a neighborhood street. Participants said SR-14 feels like a neighborhood street to the Bingen community and it should have additional safety measures.
- Transit options should be considered to get workers to and from Bingen Point Business Park.
- Through trucks should not be allowed on SR-14 when I-84 closes. The resulting congestion immobilizes Bingen and the road damage is too severe.
- There needs to be a strategy to reduce the number of heavy trucks passing through Bingen daily on SR-14. SR-14 has many narrow points and few passing lanes, creating a safety issue. SR-14 is not built for the number of heavy trucks it hosts and receives heavy damage. WSDOT should coordinate with ODOT to identify reasons why truck traffic on SR-14 does not use I-84 and develop solutions. Participants noted that trucks making local shipments in Bingen are not a problem.

Other comments

- Seasonality will be important for the circulation study. Traffic increases in good weather. It would be ideal to collect a full year of data.
- Maintenance of stormwater facilities on SR-14 is important to Underwood Fruit to prevent runoff from flowing into their property.
- The Hood River Bridge and Bridge of the Gods were closed to heavy trucks with short notice, forcing trucks to cross the Columbia River at The Dalles. Now heavy truck traffic through the region is concentrated at The Dalles Bridge. There could be significant impacts to businesses that depend on large trucks if The Dalles Bridge was suddenly closed to heavy traffic.
- The Hood River Bridge needs to be replaced to relieve congestion and allow pedestrian, bicycle and heavy truck traffic.
- The potential of a train derailment in Bingen needs to be addressed. There needs to be an evacuation plan for Bingen Point Business Park in case a train derailment blocks the business park exit.
- Klickitat County Emergency Management coordinated a study regarding first responder plans including a plan for emergencies on Bingen Point. The plan was updated within the last year and may have useful information for the circulation study.
- A future grade-separated railroad overpass accessing Bingen Point should be combined with a new bridge across the Columbia River. Combining these projects could be a more efficient use of resources, create a second entrance/exit to Bingen Point Business Park, and provide distance from other congestion points in Hood River.
- There have been discussions about creating an SR-14 bypass through Bingen to relieve congestion and slow traffic on Steuben Street and make Steuben Street more accommodating to pedestrians. Some participants identified Depot Street as a potential bypass route. Some Bingen businesses do not like this idea because it could reduce visibility and exposure of businesses on SR-14.
- SDS Lumber needs to be mitigated for any impacts to their business resulting from a grade separated railroad crossing. They need to retain two entrances/access points for their operations.
- People who have recently moved to Bingen are creating a culture shift away from small town farm life to a busier, recreation focus.
- Insitu is chartering buses to commute employees from Vancouver and shuttle employees between facilities.
- Community members expressed gratitude to WSDOT for keeping SR-14 open during harsh winter weather conditions.

Additional comments outside of the circulation study area

- Safety and efficiency is an issue for heavy trucks on SR-14. There are no passing lanes between Bingen and The Dalles. Trucks are sometimes forced to travel slower behind cyclists or sight seers because trucks cannot pass safely.
- Participants said they would like passing lanes added to SR-14, but also said it may not be helpful if there are narrow "choke" points that cannot be widened due to geography.
- Southbound traffic on SR-141 needs a left turn lane at the intersection with Skyline Drive to help prevent rear-end collisions.
- Drivers trying to turn onto SR-141 from Skyline Drive have poor visibility due to utility poles at the intersection.

- Changing Dock Grade Road to one-way seemed unnecessary and seems to have increased congestion on SR-141 in the evening.
- Riley Materials has filed a claim with Washington State for trucks damaged by an unmaintained road shoulder at Stone Road. SDS Lumber also uses Stone Road to access a rock quarry.
- There needs to be safe river access on SR-14 at popular recreation sites west of the Hood River Bridge.

Other stakeholders to consider including in future interviews

Participants said businesses that depend on large trucks in the circulation study area were well represented in the interview pool. Some participants suggested interviewing more community members, emergency responders or different varieties of businesses.

- Recreation businesses – Zolar Rafting
- Technology businesses – Sagetech, Innovative Composite Engineering
- Emergency responders – Fire District #3, Local ambulance service
- Community members – Bridge RV Park Office, White Salmon residents
- Mt. Adams Chamber of Commerce
- School bus operators

Interview questions

The following questions were used to guide discussions with interview participants. Some questions were tailored to the type of stakeholder being interviewed depending on whether they were representing interests of businesses, emergency responders or community members.

- What is your role at your business/organization?
- Describe the size and nature of your business/organization.
- How do you expect your business/organization to grow over the next 5 years? 10 years or more?
- What are your observations of traffic on SR-14? How has traffic changed over the past five years? How do you think traffic will change over the next 5 years?
- What is the importance of SR-14 to your business/organization operations?
- *Emergency responders only:* Where are critical pathways for emergency responders?
- What current problems or issues exist on SR-14 that affect your business/organization operations?
- Are there foreseeable problems in the future to consider?
- How could SR-14 better serve the needs of your business/organization?
- How could SR-14 better serve the needs of the community?
- Are there other organizations we should be sure to speak with?
- Is there anything else you would like to share that I have not asked about?

APPENDIX C – NATIVE TRAFFIC DATA

LOCATION: SR-141 Alt -- SR-14
CITY/STATE: White Salmon, WA

QC JOB #: 139103117
DATE: Tue, Oct 04 2016

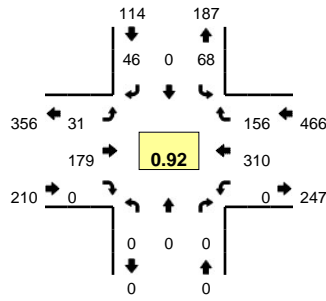

Peak-Hour: 4:05 PM -- 5:05 PM
Peak 15-Min: 4:35 PM -- 4:50 PM

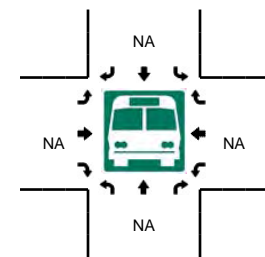
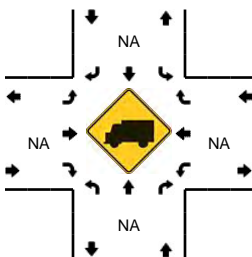
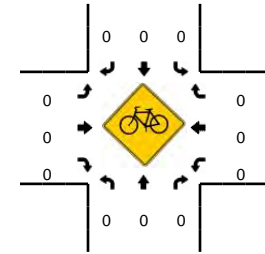
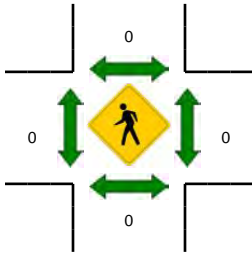
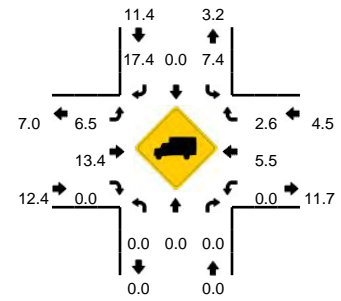

5-Min Count Period Beginning At	SR-141 Alt (Northbound)				SR-141 Alt (Southbound)				SR-14 (Eastbound)				SR-14 (Westbound)				Total	Hourly Totals
	Left	Thru	Right	U	Left	Thru	Right	U	Left	Thru	Right	U	Left	Thru	Right	U		
3:35 PM	0	0	0	0	5	0	3	0	1	25	0	0	0	20	12	0	66	658
3:40 PM	0	0	0	0	2	0	6	0	1	11	0	0	0	22	12	0	54	650
3:45 PM	0	0	0	0	7	0	6	0	0	21	0	0	0	26	7	0	67	673
3:50 PM	0	0	0	0	8	0	1	0	0	15	0	0	0	18	10	0	52	683
3:55 PM	0	0	0	0	3	0	7	0	4	13	0	0	0	23	10	0	60	689
4:00 PM	0	0	0	0	8	0	0	0	2	15	0	0	0	22	3	0	50	672
4:05 PM	0	0	0	0	4	0	5	0	0	21	0	0	0	21	13	0	64	681
4:10 PM	0	0	0	0	5	0	4	0	6	10	0	0	0	31	11	0	67	706
4:15 PM	0	0	0	0	3	0	4	0	4	15	0	0	0	18	15	0	59	708
4:20 PM	0	0	0	0	6	0	4	0	2	24	0	0	0	30	6	0	72	726
4:25 PM	0	0	0	0	5	0	6	0	2	14	0	0	0	27	12	0	66	740
4:30 PM	0	0	0	0	2	0	4	0	3	12	0	0	0	17	6	0	44	721
4:35 PM	0	0	0	0	9	0	4	0	2	17	0	0	0	33	14	0	79	734
4:40 PM	0	0	0	0	7	0	1	0	3	12	0	0	0	25	13	0	61	741
4:45 PM	0	0	0	0	8	0	4	0	3	15	0	0	0	29	16	0	75	749
4:50 PM	0	0	0	0	3	0	5	0	4	9	0	0	0	21	25	0	67	764
4:55 PM	0	0	0	0	10	0	1	0	0	15	0	0	0	32	13	0	71	775
5:00 PM	0	0	0	0	6	0	4	0	2	15	0	0	0	26	12	0	65	790
5:05 PM	0	0	0	0	3	0	1	0	3	10	0	0	0	26	11	0	54	780
5:10 PM	0	0	0	0	7	0	2	0	6	16	0	0	0	30	9	0	70	783
5:15 PM	0	0	0	0	4	0	5	0	3	9	0	0	0	34	11	0	66	790
5:20 PM	0	0	0	0	8	0	3	0	3	9	0	0	0	23	9	0	55	773
5:25 PM	0	0	0	0	5	0	2	0	0	17	0	0	0	34	13	0	71	778
5:30 PM	0	0	0	0	2	0	3	0	3	11	0	0	0	18	16	0	53	787
Peak 15-Min Flowrates	Northbound				Southbound				Eastbound				Westbound				Total	
	Left	Thru	Right	U	Left	Thru	Right	U	Left	Thru	Right	U	Left	Thru	Right	U		
All Vehicles	0	0	0	0	96	0	36	0	32	176	0	0	0	348	172	0	860	
Heavy Trucks	0	0	0	0	12	0	8	0	0	20	0	0	0	20	8	0	68	
Pedestrians	0	0	0	0	0	0	0	0	0	0	0	0	0	0	0	0	0	
Bicycles	0	0	0	0	0	0	0	0	0	0	0	0	0	0	0	0	0	
Railroad																		
Stopped Buses																		

Comments:

LOCATION: SR-141 Alt -- SR-14
CITY/STATE: White Salmon, WA

QC JOB #: 139103116
DATE: Thu, Oct 06 2016

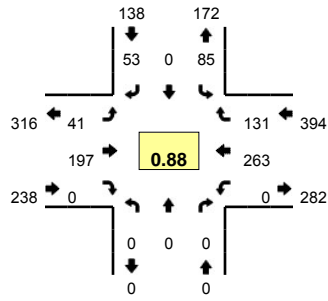

Peak-Hour: 3:35 PM -- 4:35 PM
Peak 15-Min: 3:35 PM -- 3:50 PM

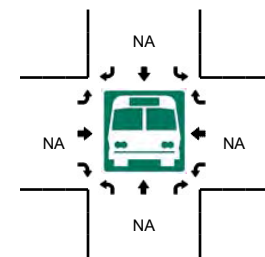
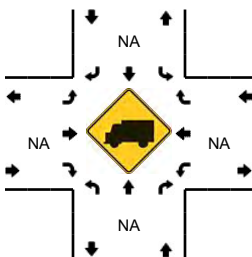
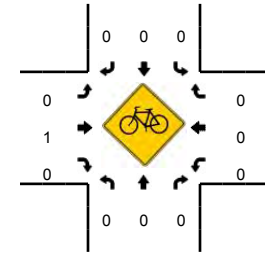
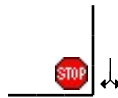
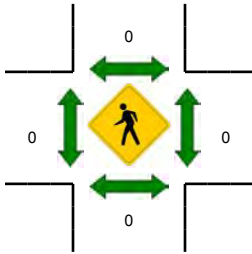
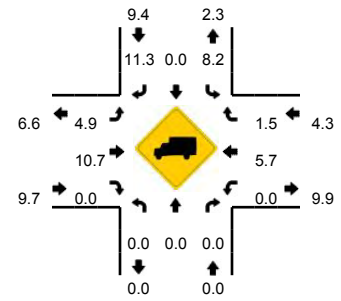

5-Min Count Period Beginning At	SR-141 Alt (Northbound)				SR-141 Alt (Southbound)				SR-14 (Eastbound)				SR-14 (Westbound)				Total	Hourly Totals
	Left	Thru	Right	U	Left	Thru	Right	U	Left	Thru	Right	U	Left	Thru	Right	U		
3:05 PM	0	0	0	0	4	0	3	0	1	8	0	0	0	31	5	0	52	569
3:10 PM	0	0	0	0	8	0	2	0	1	21	0	0	0	21	8	0	61	568
3:15 PM	0	0	0	0	7	0	2	0	0	9	0	0	0	25	10	0	53	584
3:20 PM	0	0	0	0	9	0	0	0	1	18	0	0	0	19	6	0	53	591
3:25 PM	0	0	0	0	6	0	5	0	4	13	0	0	0	23	5	0	56	601
3:30 PM	0	0	0	0	4	0	6	0	4	16	0	0	0	12	10	1	53	617
3:35 PM	0	0	0	0	10	0	5	0	5	16	0	0	0	18	12	0	66	628
3:40 PM	0	0	0	0	9	0	4	0	6	23	0	0	0	31	13	0	86	676
3:45 PM	0	0	0	0	10	0	3	0	2	19	0	0	0	25	8	0	67	693
3:50 PM	0	0	0	0	4	0	5	0	5	15	0	0	0	24	8	0	61	700
3:55 PM	0	0	0	0	8	0	3	0	3	12	0	0	0	16	13	0	55	712
4:00 PM	0	0	0	0	4	0	3	0	2	18	0	0	0	14	6	0	47	710
4:05 PM	0	0	0	0	3	0	3	0	4	19	0	0	0	20	13	0	62	720
4:10 PM	0	0	0	0	4	0	11	0	3	9	0	0	0	28	17	0	72	731
4:15 PM	0	0	0	0	8	0	4	0	3	14	0	0	0	17	14	0	60	738
4:20 PM	0	0	0	0	5	0	6	0	3	15	0	0	0	26	8	0	63	748
4:25 PM	0	0	0	0	9	0	5	0	3	22	0	0	0	28	10	0	77	769
4:30 PM	0	0	0	0	11	0	1	0	2	15	0	0	0	16	9	0	54	770
4:35 PM	0	0	0	0	10	0	2	0	3	10	0	0	0	22	12	0	59	763
4:40 PM	0	0	0	0	12	0	1	0	3	7	0	0	0	21	17	0	61	738
4:45 PM	0	0	0	0	7	0	2	0	2	17	0	0	0	32	19	0	79	750
4:50 PM	0	0	0	0	6	0	2	0	2	12	0	0	0	17	10	0	49	738
4:55 PM	0	0	0	0	2	0	2	0	2	17	0	0	0	29	12	0	64	747
5:00 PM	0	0	0	0	6	0	2	0	7	12	0	0	0	17	7	0	51	751
Peak 15-Min Flowrates	Northbound				Southbound				Eastbound				Westbound				Total	
	Left	Thru	Right	U	Left	Thru	Right	U	Left	Thru	Right	U	Left	Thru	Right	U		
All Vehicles	0	0	0	0	116	0	48	0	52	232	0	0	0	296	132	0	876	
Heavy Trucks	0	0	0	0	8	0	0	0	8	24	0	0	0	32	4	0	76	
Pedestrians	0	0	0	0	0	0	0	0	0	0	0	0	0	0	0	0	0	
Bicycles	0	0	0	0	0	0	0	0	0	0	0	0	0	0	0	0	0	
Railroad																		
Stopped Buses																		

Comments:

LOCATION: S Dock Grade Rd -- SR-14
CITY/STATE: White Salmon, WA

QC JOB #: 139103132
DATE: Tue, Oct 04 2016

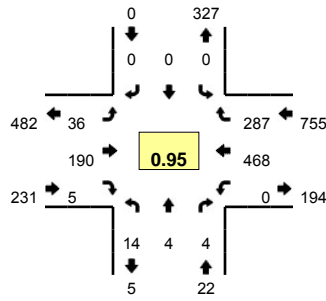

Peak-Hour: 4:40 PM -- 5:40 PM
Peak 15-Min: 5:10 PM -- 5:25 PM

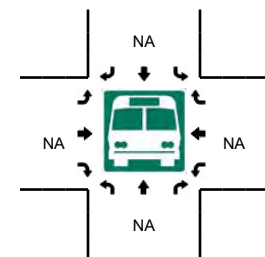
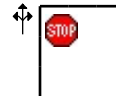
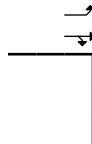
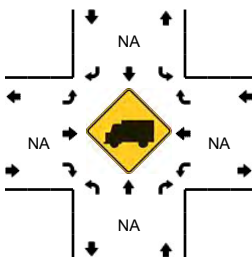
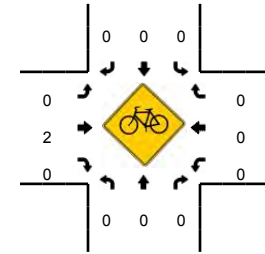
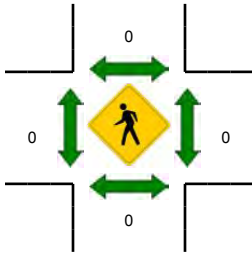
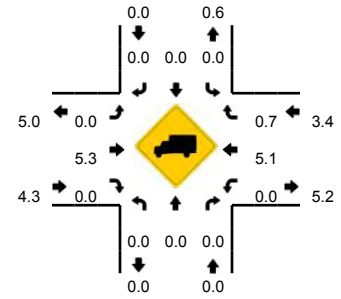

5-Min Count Period Beginning At	S Dock Grade Rd (Northbound)				S Dock Grade Rd (Southbound)				SR-14 (Eastbound)				SR-14 (Westbound)				Total	Hourly Totals
	Left	Thru	Right	U	Left	Thru	Right	U	Left	Thru	Right	U	Left	Thru	Right	U		
4:10 PM	1	0	0	0	0	0	0	0	3	15	0	0	0	37	24	0	80	850
4:15 PM	0	0	0	0	0	0	0	0	2	11	0	0	0	40	12	0	65	852
4:20 PM	2	0	0	0	0	0	0	0	5	20	1	0	0	40	21	0	89	871
4:25 PM	0	0	0	0	0	0	0	0	6	26	0	0	0	24	20	0	76	883
4:30 PM	1	1	0	0	0	0	0	0	2	13	0	0	1	31	18	0	67	881
4:35 PM	0	0	0	0	0	0	0	0	2	9	0	1	0	44	26	0	82	878
4:40 PM	0	0	0	0	0	0	0	0	4	24	1	0	0	43	19	0	91	890
4:45 PM	2	0	0	0	0	0	0	0	0	18	0	0	0	39	15	0	74	909
4:50 PM	4	2	0	0	0	0	0	0	2	17	0	0	0	38	28	0	91	934
4:55 PM	2	0	0	0	0	0	0	0	3	14	1	0	0	44	15	0	79	928
5:00 PM	1	0	0	0	0	0	0	0	5	20	0	0	0	33	28	0	87	951
5:05 PM	1	0	1	0	0	0	0	0	5	6	0	0	0	36	22	0	71	952
5:10 PM	1	0	1	0	0	0	0	0	2	12	1	0	0	43	33	0	93	965
5:15 PM	2	0	1	0	0	0	0	0	2	19	0	0	0	41	21	0	86	986
5:20 PM	0	0	0	0	0	0	0	0	3	18	0	0	0	39	27	0	87	984
5:25 PM	1	1	0	0	0	0	0	0	1	12	1	0	0	37	28	0	81	989
5:30 PM	0	0	1	0	0	0	0	0	3	13	0	0	0	38	24	0	79	1001
5:35 PM	0	1	0	0	0	0	0	0	6	17	1	0	0	37	27	0	89	1008
5:40 PM	0	0	1	0	0	0	0	0	4	14	0	0	0	42	24	0	85	1002
5:45 PM	1	0	1	0	0	0	0	0	5	24	0	0	0	20	20	0	71	999
5:50 PM	0	0	0	0	0	0	0	0	5	16	0	0	0	36	21	0	78	986
5:55 PM	0	0	0	0	0	0	0	0	6	8	0	0	0	25	20	0	59	966
6:00 PM	0	0	0	0	0	0	0	0	6	22	0	0	1	15	19	0	63	942
6:05 PM	0	0	0	0	0	0	0	0	4	10	0	0	0	24	20	0	58	929
Peak 15-Min Flowrates	Northbound				Southbound				Eastbound				Westbound				Total	
	Left	Thru	Right	U	Left	Thru	Right	U	Left	Thru	Right	U	Left	Thru	Right	U		
All Vehicles	12	0	8	0	0	0	0	0	28	196	4	0	0	492	324	0	1064	
Heavy Trucks	0	0	0	0	0	0	0	0	0	12	0	0	0	12	0	0	24	
Pedestrians	0	0	0	0	0	0	0	0	0	0	0	0	0	0	0	0	0	
Bicycles	0	0	0	0	0	0	0	0	0	0	0	0	0	0	0	0	0	
Railroad																		
Stopped Buses																		

Comments:

LOCATION: S Dock Grade Rd -- SR-14
CITY/STATE: White Salmon, WA

QC JOB #: 139103131
DATE: Thu, Oct 06 2016

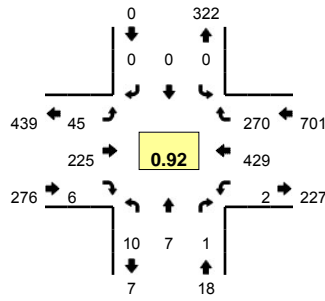

Peak-Hour: 4:25 PM -- 5:25 PM
Peak 15-Min: 5:10 PM -- 5:25 PM

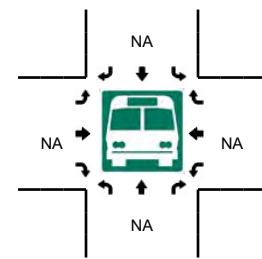
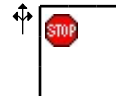
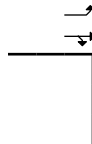
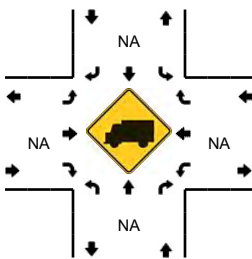
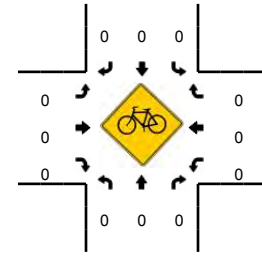
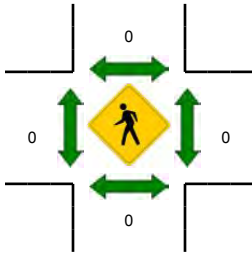
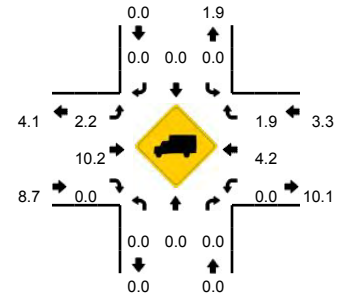

5-Min Count Period Beginning At	S Dock Grade Rd (Northbound)				S Dock Grade Rd (Southbound)				SR-14 (Eastbound)				SR-14 (Westbound)				Total	Hourly Totals
	Left	Thru	Right	U	Left	Thru	Right	U	Left	Thru	Right	U	Left	Thru	Right	U		
3:55 PM	0	0	0	0	0	0	0	0	4	10	1	0	0	38	18	0	71	858
4:00 PM	0	1	0	0	0	0	0	0	0	17	1	0	0	17	21	0	57	859
4:05 PM	0	1	1	0	0	0	0	0	9	17	1	0	1	39	22	0	91	885
4:10 PM	0	1	1	0	0	0	0	0	3	8	2	0	0	44	20	0	79	889
4:15 PM	1	1	0	0	0	0	0	0	6	18	0	0	0	29	30	0	85	917
4:20 PM	0	0	0	0	0	0	0	0	1	24	1	0	1	33	18	0	78	932
4:25 PM	0	1	1	0	0	0	0	0	6	23	0	0	0	38	21	0	90	953
4:30 PM	2	0	0	0	0	0	0	0	3	20	1	0	0	32	16	0	74	967
4:35 PM	3	1	0	0	0	0	0	0	3	25	1	0	0	33	19	1	86	965
4:40 PM	1	0	0	0	0	0	0	0	0	11	0	0	1	36	24	0	73	946
4:45 PM	0	0	0	0	0	0	0	0	6	23	0	0	0	51	28	0	108	964
4:50 PM	1	2	0	0	0	0	0	0	3	11	3	0	0	29	24	0	73	965
4:55 PM	0	0	0	0	0	0	0	0	3	18	0	0	0	32	16	0	69	963
5:00 PM	0	0	0	0	0	0	0	0	3	21	0	0	0	26	24	0	74	980
5:05 PM	2	0	0	0	0	0	0	0	3	19	1	0	0	28	26	0	79	968
5:10 PM	1	2	0	0	0	0	0	0	6	23	0	0	0	47	24	0	103	992
5:15 PM	0	1	0	0	0	0	0	0	5	11	0	0	0	38	27	0	82	989
5:20 PM	0	0	0	0	0	0	0	0	4	20	0	0	0	39	21	0	84	995
5:25 PM	0	0	0	0	0	0	0	0	6	16	1	0	0	31	21	0	75	980
5:30 PM	0	1	0	0	0	0	0	0	7	9	0	0	0	36	26	0	79	985
5:35 PM	1	0	0	0	0	0	0	0	2	10	0	0	0	35	23	0	71	970
5:40 PM	0	2	0	0	0	0	0	0	3	16	0	0	1	28	22	0	72	969
5:45 PM	1	0	0	0	0	0	0	0	6	13	1	0	0	40	23	0	84	945
5:50 PM	0	0	1	0	0	0	0	0	5	11	1	0	1	19	22	0	60	932
Peak 15-Min Flowrates	Northbound				Southbound				Eastbound				Westbound				Total	
	Left	Thru	Right	U	Left	Thru	Right	U	Left	Thru	Right	U	Left	Thru	Right	U		
All Vehicles	4	12	0	0	0	0	0	0	60	216	0	0	0	496	288	0	1076	
Heavy Trucks	0	0	0	0	0	0	0	0	0	8	0	0	0	16	8	0	32	
Pedestrians	0	0	0	0	0	0	0	0	0	0	0	0	0	0	0	0	0	
Bicycles	0	0	0	0	0	0	0	0	0	0	0	0	0	0	0	0	0	
Railroad																		
Stopped Buses																		

Comments:

LOCATION: Hood River Bridge -- SR-14
CITY/STATE: White Salmon, WA

QC JOB #: 139103120
DATE: Tue, Oct 04 2016

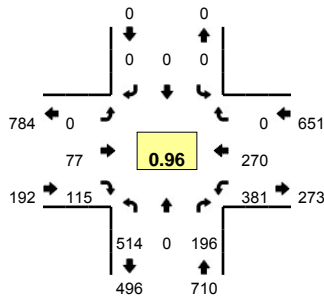

Peak-Hour: 4:30 PM -- 5:30 PM
Peak 15-Min: 5:10 PM -- 5:25 PM

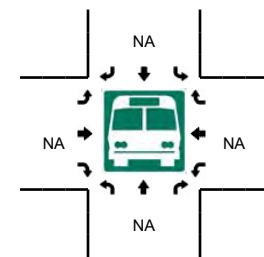
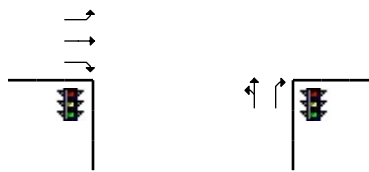
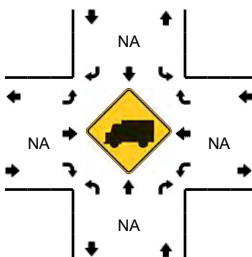
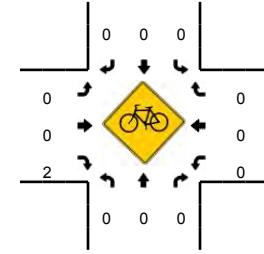
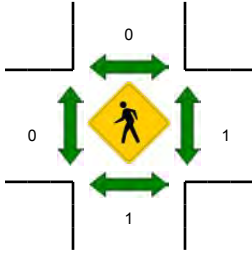
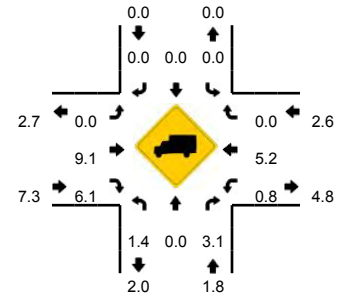

5-Min Count Period Beginning At	Hood River Bridge (Northbound)				Hood River Bridge (Southbound)				SR-14 (Eastbound)				SR-14 (Westbound)				Total	Hourly Totals
	Left	Thru	Right	U	Left	Thru	Right	U	Left	Thru	Right	U	Left	Thru	Right	U		
4:00 PM	18	0	9	0	0	0	0	0	0	11	13	0	24	27	0	0	102	1335
4:05 PM	31	0	14	0	0	0	0	0	0	9	7	0	27	22	0	0	110	1349
4:10 PM	36	0	12	0	0	0	0	0	0	7	10	0	43	20	0	0	128	1369
4:15 PM	30	0	10	0	0	0	0	0	0	7	6	0	36	23	0	0	112	1378
4:20 PM	44	0	9	0	0	0	0	0	0	9	10	0	30	21	0	0	123	1393
4:25 PM	25	0	16	0	0	0	0	0	0	12	14	0	38	17	0	0	122	1418
4:30 PM	28	0	21	0	0	0	0	0	0	9	6	0	27	22	0	0	113	1416
4:35 PM	48	0	15	0	0	0	0	0	0	3	7	0	36	20	0	0	129	1420
4:40 PM	38	0	15	0	0	0	0	0	0	8	14	0	41	26	0	0	142	1440
4:45 PM	41	0	19	0	0	0	0	0	0	12	8	0	28	19	0	0	127	1467
4:50 PM	40	0	19	0	0	0	0	0	0	4	11	0	31	29	0	0	134	1478
4:55 PM	40	0	13	0	0	0	0	0	0	6	7	0	34	27	0	0	127	1469
5:00 PM	44	0	16	0	0	0	0	0	0	4	17	0	34	18	0	0	133	1500
5:05 PM	43	0	16	0	0	0	0	0	0	4	2	0	33	20	0	0	118	1508
5:10 PM	49	0	10	0	0	0	0	0	0	5	11	0	39	35	0	0	149	1529
5:15 PM	45	0	16	0	0	0	0	0	0	10	15	0	33	14	0	0	133	1550
5:20 PM	51	0	18	0	0	0	0	0	0	8	9	0	16	20	0	0	122	1549
5:25 PM	47	0	18	0	0	0	0	0	0	4	8	0	29	20	0	0	126	1553
5:30 PM	31	0	13	0	0	0	0	0	0	3	13	0	27	26	0	0	113	1553
5:35 PM	54	0	17	0	0	0	0	0	0	7	11	0	22	16	0	0	127	1551
5:40 PM	42	0	16	0	0	0	0	0	0	5	11	0	43	19	0	0	136	1545
5:45 PM	26	0	13	0	0	0	0	0	0	12	11	0	29	13	0	0	104	1522
5:50 PM	53	0	10	0	0	0	0	0	0	6	13	0	27	12	0	0	121	1509
5:55 PM	24	0	7	0	0	0	0	0	0	2	7	0	21	11	0	0	72	1454
Peak 15-Min Flowrates	Northbound				Southbound				Eastbound				Westbound				Total	
	Left	Thru	Right	U	Left	Thru	Right	U	Left	Thru	Right	U	Left	Thru	Right	U		
All Vehicles	580	0	176	0	0	0	0	0	0	92	140	0	352	276	0	0	1616	
Heavy Trucks	8	0	8	0	0	0	0	0	0	0	12	0	4	8	0	0	40	
Pedestrians	0	0	0	0	0	0	0	0	0	0	0	0	0	0	0	0	0	
Bicycles	0	0	0	0	0	0	0	0	0	0	0	0	0	0	0	0	0	
Railroad																		
Stopped Buses																		

Comments:

LOCATION: Hood River Bridge -- SR-14
CITY/STATE: White Salmon, WA

QC JOB #: 139103119
DATE: Thu, Oct 06 2016

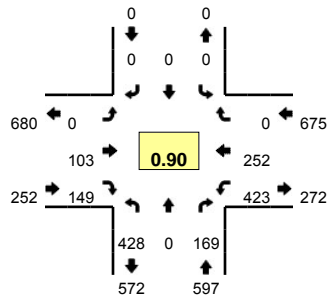

Peak-Hour: 3:35 PM -- 4:35 PM
Peak 15-Min: 3:35 PM -- 3:50 PM

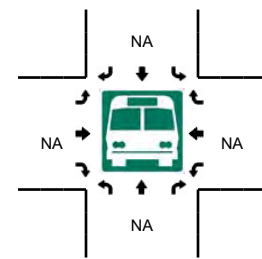
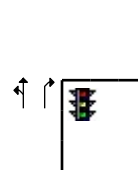
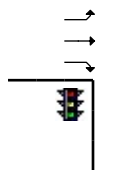
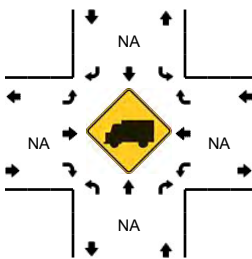
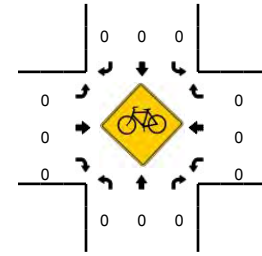
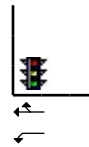
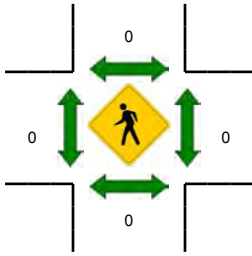
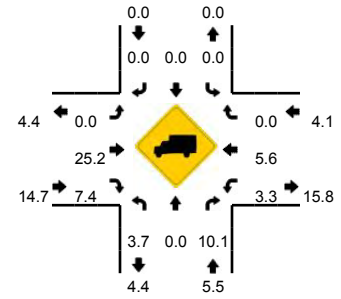

5-Min Count Period Beginning At	Hood River Bridge (Northbound)				Hood River Bridge (Southbound)				SR-14 (Eastbound)				SR-14 (Westbound)				Total	Hourly Totals
	Left	Thru	Right	U	Left	Thru	Right	U	Left	Thru	Right	U	Left	Thru	Right	U		
3:05 PM	26	0	7	0	0	0	1	0	0	7	12	0	32	18	0	0	103	1175
3:10 PM	39	0	19	0	0	0	0	0	0	4	13	0	31	15	0	0	121	1180
3:15 PM	19	0	10	0	0	0	0	0	0	8	11	0	31	13	0	0	92	1168
3:20 PM	27	0	23	0	0	0	0	0	0	5	10	0	21	13	0	0	99	1172
3:25 PM	21	0	8	0	0	0	0	0	0	10	17	0	30	17	0	0	103	1180
3:30 PM	29	0	19	0	0	0	0	0	0	8	3	0	35	19	0	0	113	1206
3:35 PM	40	0	23	0	0	0	0	0	0	9	18	0	34	19	0	0	143	1255
3:40 PM	34	0	11	0	0	0	0	0	0	5	21	0	40	28	0	0	139	1300
3:45 PM	46	0	14	0	0	0	0	0	0	11	16	0	32	20	0	0	139	1335
3:50 PM	33	0	22	0	0	0	0	0	0	8	9	0	27	12	0	0	111	1348
3:55 PM	25	0	10	0	0	0	0	0	0	8	5	0	39	25	0	0	112	1366
4:00 PM	36	0	11	0	0	0	0	0	0	6	10	0	35	13	0	0	111	1386
4:05 PM	46	0	11	0	0	0	0	0	0	15	10	0	34	23	0	0	139	1422
4:10 PM	35	0	11	0	0	0	0	0	0	6	5	0	34	30	0	0	121	1422
4:15 PM	48	0	21	0	0	0	0	0	0	9	11	0	30	16	0	0	135	1465
4:20 PM	27	0	15	0	0	0	0	0	0	9	14	0	34	24	0	0	123	1489
4:25 PM	32	0	12	0	0	0	0	0	0	13	14	0	40	21	0	0	132	1518
4:30 PM	26	0	8	0	0	0	0	0	0	4	16	0	44	21	0	0	119	1524
4:35 PM	40	0	14	0	0	0	0	0	0	11	16	0	29	17	0	0	127	1508
4:40 PM	42	0	11	0	0	0	0	0	0	3	7	0	31	22	0	0	116	1485
4:45 PM	48	0	16	0	0	0	0	0	0	5	13	0	32	21	0	0	135	1481
4:50 PM	37	0	24	0	0	0	0	0	0	9	8	0	29	19	0	0	126	1496
4:55 PM	30	0	14	0	0	0	0	0	0	9	7	0	33	21	0	0	114	1498
5:00 PM	40	0	15	0	0	0	0	0	0	9	9	0	31	16	0	0	120	1507
Peak 15-Min Flowrates	Northbound				Southbound				Eastbound				Westbound				Total	
	Left	Thru	Right	U	Left	Thru	Right	U	Left	Thru	Right	U	Left	Thru	Right	U		
All Vehicles	480	0	192	0	0	0	0	0	0	100	220	0	424	268	0	0	1684	
Heavy Trucks	36	0	24	0	0	0	0	0	0	20	12	0	4	8	0	0	104	
Pedestrians	0	0	0	0	0	0	0	0	0	0	0	0	0	0	0	0	0	
Bicycles	0	0	0	0	0	0	0	0	0	0	0	0	0	0	0	0	0	
Railroad																		
Stopped Buses																		

Comments:

LOCATION: Walnut St -- SR-14
CITY/STATE: Cook, WA

QC JOB #: 139103123
DATE: Tue, Oct 04 2016

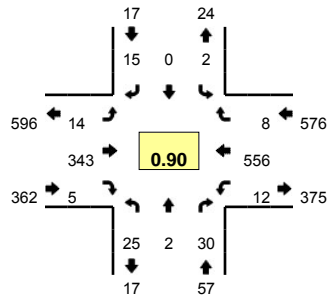

Peak-Hour: 3:55 PM -- 4:55 PM
Peak 15-Min: 4:30 PM -- 4:45 PM

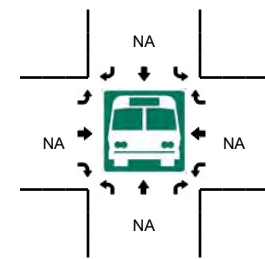
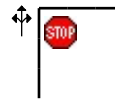
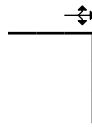
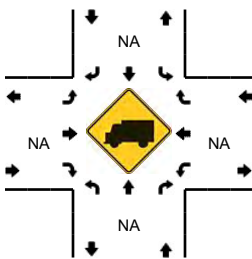
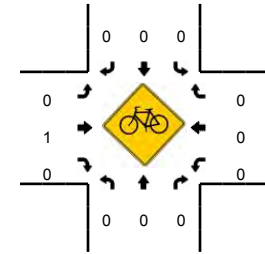
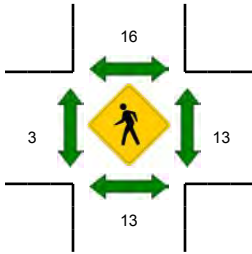
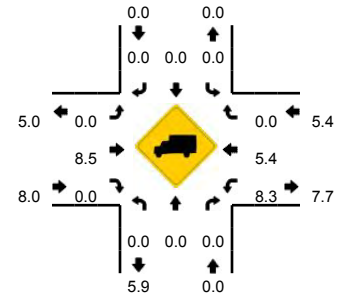

5-Min Count Period Beginning At	Walnut St (Northbound)				Walnut St (Southbound)				SR-14 (Eastbound)				SR-14 (Westbound)				Total	Hourly Totals
	Left	Thru	Right	U	Left	Thru	Right	U	Left	Thru	Right	U	Left	Thru	Right	U		
3:25 PM	1	0	3	0	2	0	1	0	0	20	1	0	1	40	1	0	70	776
3:30 PM	3	0	8	0	1	0	1	0	0	21	0	0	1	47	2	0	84	802
3:35 PM	5	0	6	0	1	0	0	0	1	29	1	0	0	48	0	0	91	811
3:40 PM	1	1	2	0	0	0	1	0	0	19	1	0	1	52	3	0	81	832
3:45 PM	3	0	1	0	0	0	2	0	1	21	0	0	2	41	3	0	74	845
3:50 PM	0	0	4	0	0	0	0	0	0	30	2	0	1	36	0	0	73	858
3:55 PM	0	0	3	0	0	0	2	0	1	33	1	0	2	50	0	0	92	883
4:00 PM	3	0	2	0	0	0	0	0	3	39	1	0	0	26	1	0	75	888
4:05 PM	2	0	2	0	1	0	1	0	2	43	0	0	2	50	0	0	103	927
4:10 PM	0	0	4	0	0	0	0	0	1	36	0	0	0	43	1	0	85	953
4:15 PM	3	1	3	0	1	0	2	0	0	19	0	0	0	46	0	0	75	968
4:20 PM	2	0	1	0	0	0	2	0	0	20	1	0	0	50	1	0	77	980
4:25 PM	0	0	1	0	0	0	2	0	0	18	1	0	0	41	1	0	64	974
4:30 PM	3	1	6	0	0	0	0	0	3	39	0	0	2	38	0	0	92	982
4:35 PM	3	0	6	0	0	0	2	0	0	28	1	0	5	59	1	0	105	996
4:40 PM	2	0	0	0	0	0	2	0	0	28	0	0	0	50	1	0	83	998
4:45 PM	5	0	1	0	0	0	0	0	2	19	0	0	1	48	1	0	77	1001
4:50 PM	2	0	1	0	0	0	2	0	2	21	0	0	0	55	1	0	84	1012
4:55 PM	1	0	4	0	1	0	2	0	1	21	0	0	0	50	0	0	80	1000
5:00 PM	2	0	1	0	1	0	0	0	1	23	1	0	1	50	3	0	83	1008
5:05 PM	0	0	1	0	0	0	2	0	1	27	0	0	0	58	1	0	90	995
5:10 PM	1	0	4	0	1	0	1	0	1	19	0	0	0	45	0	0	72	982
5:15 PM	2	0	1	0	0	0	1	0	0	25	1	0	0	41	0	0	71	978
5:20 PM	2	0	0	0	0	0	0	0	1	16	2	0	0	33	0	0	54	955
Peak 15-Min Flowrates	Northbound				Southbound				Eastbound				Westbound				Total	
	Left	Thru	Right	U	Left	Thru	Right	U	Left	Thru	Right	U	Left	Thru	Right	U		
All Vehicles	32	4	48	0	0	0	16	0	12	380	4	0	28	588	8	0	1120	
Heavy Trucks	0	0	0		0	0	0		0	20	0		4	28	0		52	
Pedestrians		16				12				8				16			52	
Bicycles	0	0	0		0	0	0		0	0	0		0	0	0		0	
Railroad																		
Stopped Buses																		

Comments:

LOCATION: Walnut St -- SR-14
CITY/STATE: Cook, WA

QC JOB #: 139103122
DATE: Thu, Oct 06 2016

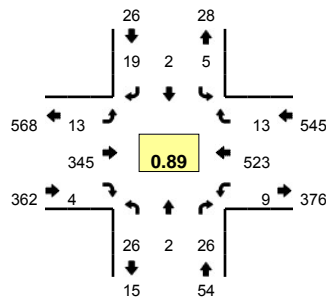

Peak-Hour: 3:35 PM -- 4:35 PM
Peak 15-Min: 4:00 PM -- 4:15 PM

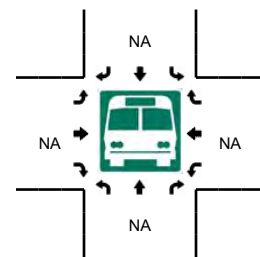
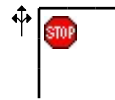
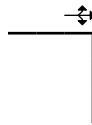
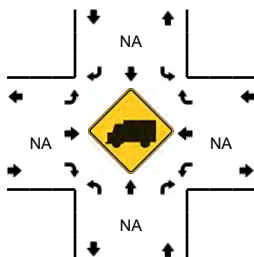
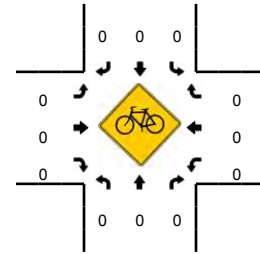
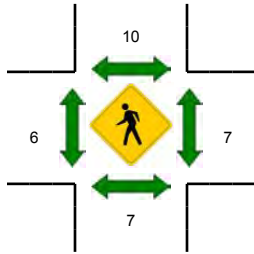
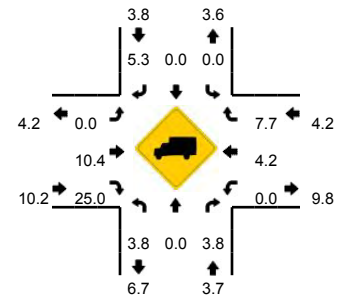

5-Min Count Period Beginning At	Walnut St (Northbound)				Walnut St (Southbound)				SR-14 (Eastbound)				SR-14 (Westbound)				Total	Hourly Totals
	Left	Thru	Right	U	Left	Thru	Right	U	Left	Thru	Right	U	Left	Thru	Right	U		
3:05 PM	5	0	4	0	1	0	1	0	0	16	4	0	0	53	1	0	85	767
3:10 PM	2	0	1	0	0	0	1	0	0	21	0	0	0	41	0	0	66	777
3:15 PM	2	0	0	0	1	0	0	0	0	22	0	0	0	32	0	0	57	764
3:20 PM	2	1	1	0	0	0	1	0	0	22	1	0	0	48	1	0	77	785
3:25 PM	1	0	1	0	0	0	2	0	1	27	1	0	0	34	1	0	68	808
3:30 PM	2	0	7	0	0	0	0	0	0	25	2	0	0	39	0	0	75	817
3:35 PM	6	0	6	0	1	1	2	0	2	34	1	0	0	51	1	0	105	867
3:40 PM	2	0	2	0	2	0	1	0	0	18	0	0	1	49	1	0	76	874
3:45 PM	1	0	1	0	0	0	1	0	1	20	0	0	1	36	1	0	62	876
3:50 PM	2	0	3	0	0	0	0	0	2	30	0	0	0	36	0	0	73	881
3:55 PM	1	0	0	0	0	0	3	0	3	40	1	0	1	36	1	0	86	902
4:00 PM	1	0	2	0	0	0	4	0	2	29	0	0	0	43	0	0	81	911
4:05 PM	1	0	1	0	0	0	1	0	1	47	0	0	3	43	4	0	101	927
4:10 PM	4	0	2	0	1	0	0	0	0	30	1	0	1	53	2	0	94	955
4:15 PM	0	0	2	0	0	1	1	0	1	20	0	0	1	42	1	0	69	967
4:20 PM	2	0	1	0	1	0	0	0	0	21	1	0	1	47	0	0	74	964
4:25 PM	2	0	2	0	0	0	3	0	0	32	0	0	0	48	0	0	87	983
4:30 PM	4	2	4	0	0	0	3	0	1	24	0	0	0	39	2	0	79	987
4:35 PM	2	0	2	0	1	0	2	0	2	15	1	0	1	44	1	0	71	953
4:40 PM	3	1	3	0	0	0	2	0	0	26	1	0	1	46	0	0	83	960
4:45 PM	1	0	2	0	0	0	0	0	1	15	1	0	1	40	2	0	63	961
4:50 PM	1	0	5	0	0	0	0	0	1	27	1	0	1	53	0	0	89	977
4:55 PM	1	0	1	0	0	0	1	0	1	27	1	0	1	35	2	0	70	961
5:00 PM	3	0	1	0	1	0	1	0	1	20	1	0	0	49	1	0	78	958
Peak 15-Min Flowrates	Northbound				Southbound				Eastbound				Westbound				Total	
	Left	Thru	Right	U	Left	Thru	Right	U	Left	Thru	Right	U	Left	Thru	Right	U		
All Vehicles	24	0	20	0	4	0	20	0	12	424	4	0	16	556	24	0	1104	
Heavy Trucks	0	0	0		0	0	0		0	32	0		0	24	4		60	
Pedestrians		16				12				8				8			44	
Bicycles	0	0	0		0	0	0		0	0	0		0	0	0		0	
Railroad																		
Stopped Buses																		

Comments:

LOCATION: Ash St -- Hwy 14
CITY/STATE: Bingen, WA

QC JOB #: 14265001
DATE: Thu, Mar 30 2017

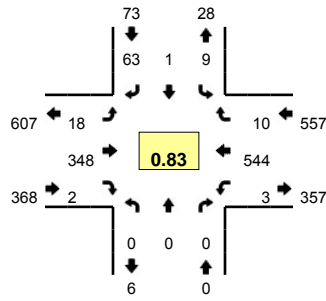

Peak-Hour: 3:15 PM -- 4:15 PM
Peak 15-Min: 3:30 PM -- 3:45 PM

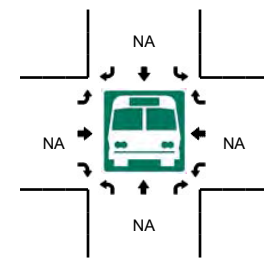
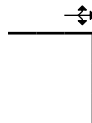
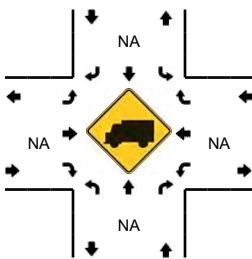
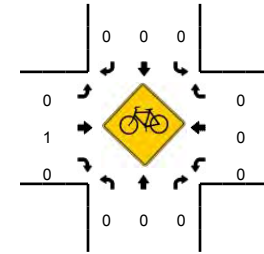
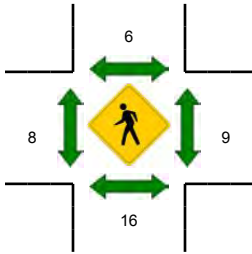
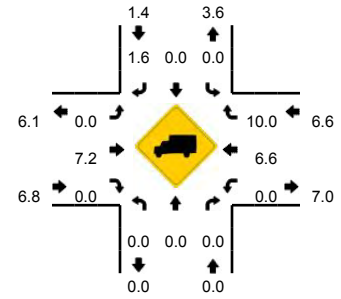

5-Min Count Period Beginning At	Ash St (Northbound)				Ash St (Southbound)				Hwy 14 (Eastbound)				Hwy 14 (Westbound)				Total	Hourly Totals	
	Left	Thru	Right	U	Left	Thru	Right	U	Left	Thru	Right	U	Left	Thru	Right	U			
2:45 PM	0	0	0	0	1	0	4	0	1	25	2	0	0	0	32	0	0	65	736
2:50 PM	0	0	0	0	0	0	4	0	2	19	0	0	0	0	30	3	0	58	731
2:55 PM	0	0	0	0	0	0	4	0	1	21	1	0	0	1	31	1	0	60	740
3:00 PM	0	0	0	0	1	0	3	0	0	30	1	0	0	1	30	1	0	67	748
3:05 PM	0	0	0	0	2	0	5	0	1	21	0	0	0	2	40	0	0	71	760
3:10 PM	0	0	0	0	2	0	5	0	1	15	0	0	0	0	42	1	1	67	766
3:15 PM	0	0	0	0	0	0	9	0	1	22	0	0	0	0	47	0	0	79	788
3:20 PM	0	0	0	0	0	0	4	0	0	26	1	0	0	0	44	1	0	76	805
3:25 PM	0	0	0	0	0	1	3	0	2	35	0	0	0	0	46	0	0	87	833
3:30 PM	0	0	0	0	1	0	8	0	2	40	0	0	0	0	48	0	0	99	872
3:35 PM	0	0	0	0	0	0	3	0	1	37	0	0	0	1	52	2	0	96	894
3:40 PM	0	0	0	0	2	0	5	0	2	39	0	0	0	1	54	3	0	106	931
3:45 PM	0	0	0	0	1	0	5	0	3	31	0	0	0	1	48	2	0	91	957
3:50 PM	0	0	0	0	1	0	4	0	2	28	0	0	0	0	41	0	0	76	975
3:55 PM	0	0	0	0	1	0	5	0	2	23	0	0	0	0	44	0	0	75	990
4:00 PM	0	0	0	0	0	0	6	0	1	20	0	0	0	0	46	0	0	73	996
4:05 PM	0	0	0	0	3	0	8	0	0	28	0	0	0	0	28	1	0	68	993
4:10 PM	0	0	0	0	0	0	3	0	2	19	1	0	0	0	46	1	0	72	998
4:15 PM	0	0	0	0	1	0	3	0	3	27	0	0	0	0	36	1	0	71	990
4:20 PM	0	0	0	0	3	0	2	0	2	18	1	0	0	0	43	1	0	70	984
4:25 PM	0	0	0	0	2	0	5	0	1	22	0	0	0	0	41	0	0	71	968
4:30 PM	0	0	0	0	0	0	1	0	2	27	1	0	0	0	50	0	0	81	950
4:35 PM	0	0	0	0	0	0	4	0	2	26	1	0	0	1	51	1	0	86	940
4:40 PM	0	0	0	0	0	0	7	0	0	18	1	0	0	0	37	0	0	63	897
Peak 15-Min Flowrates	Northbound				Southbound				Eastbound				Westbound				Total		
	Left	Thru	Right	U	Left	Thru	Right	U	Left	Thru	Right	U	Left	Thru	Right	U			
All Vehicles	0	0	0	0	12	0	64	0	20	464	0	0	8	616	20	0	1204		
Heavy Trucks	0	0	0	0	0	0	0	0	0	36	0	0	0	44	4	0	84		
Pedestrians		32			12				8				8				60		
Bicycles	0	0	0	0	0	0	0	0	0	0	0	0	0	0	0	0	0		
Railroad																			
Stopped Buses																			

Comments:

LOCATION: Oak St -- SR-14
CITY/STATE: Cook, WA

QC JOB #: 139103126
DATE: Tue, Oct 04 2016

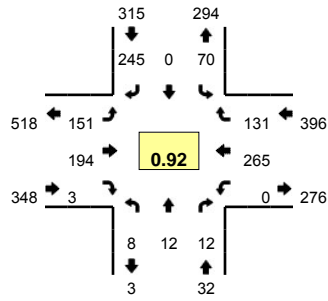

Peak-Hour: 3:55 PM -- 4:55 PM
Peak 15-Min: 4:05 PM -- 4:20 PM

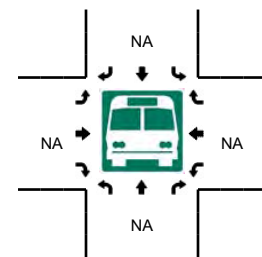
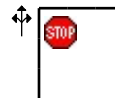
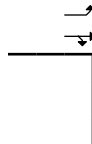
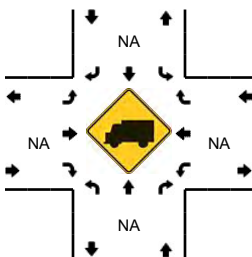
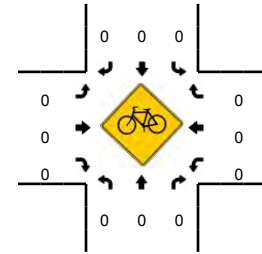
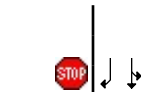
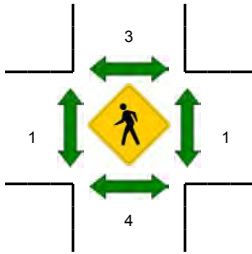
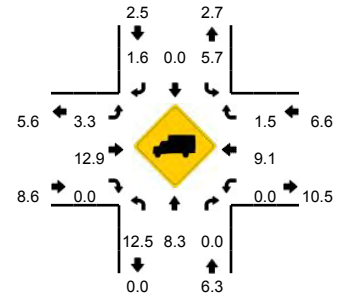

5-Min Count Period Beginning At	Oak St (Northbound)				Oak St (Southbound)				SR-14 (Eastbound)				SR-14 (Westbound)				Total	Hourly Totals
	Left	Thru	Right	U	Left	Thru	Right	U	Left	Thru	Right	U	Left	Thru	Right	U		
3:25 PM	0	0	1	0	11	0	25	0	6	20	1	0	0	17	11	0	92	875
3:30 PM	1	1	0	0	5	0	22	0	15	13	1	0	1	19	6	0	84	904
3:35 PM	1	0	0	0	4	0	23	0	12	16	0	0	1	32	9	0	98	915
3:40 PM	0	1	0	0	9	0	28	0	13	11	1	0	0	15	8	0	86	931
3:45 PM	0	0	2	0	9	0	19	0	6	15	0	0	0	27	13	0	91	946
3:50 PM	0	0	2	0	6	0	20	0	12	16	0	0	0	20	7	0	83	963
3:55 PM	1	0	2	0	5	0	17	0	13	22	0	0	0	21	12	0	93	972
4:00 PM	0	0	0	0	7	0	12	0	20	19	1	0	0	15	11	0	85	981
4:05 PM	0	0	1	0	6	0	19	0	22	22	0	0	0	27	7	0	104	1015
4:10 PM	0	2	1	0	7	0	18	0	19	17	0	0	0	23	12	0	99	1053
4:15 PM	0	2	1	0	5	0	17	0	10	14	2	0	0	30	12	0	93	1074
4:20 PM	0	2	0	0	7	0	18	0	4	9	0	0	0	27	6	0	73	1081
4:25 PM	2	0	1	0	3	0	15	0	9	8	0	0	0	19	11	0	68	1057
4:30 PM	1	0	1	0	7	0	18	0	13	21	0	0	0	17	10	0	88	1061
4:35 PM	1	2	1	0	7	0	31	0	20	18	0	0	0	21	10	0	111	1074
4:40 PM	1	2	2	0	3	0	16	0	7	19	0	0	0	24	20	0	94	1082
4:45 PM	0	2	1	0	6	0	31	0	5	14	0	0	0	21	11	0	91	1082
4:50 PM	2	0	1	0	7	0	33	0	9	11	0	0	0	20	9	0	92	1091
4:55 PM	0	1	1	0	7	0	18	0	10	15	0	0	0	18	15	0	85	1083
5:00 PM	0	0	0	0	5	0	16	0	12	12	0	0	0	25	10	0	80	1078
5:05 PM	0	1	1	0	5	0	34	0	13	17	0	0	0	24	10	0	105	1079
5:10 PM	1	3	1	0	6	1	19	0	5	12	0	0	0	16	12	0	76	1056
5:15 PM	1	0	0	0	4	0	18	0	11	13	0	0	0	19	8	0	74	1037
5:20 PM	0	0	0	0	6	1	10	0	5	13	0	0	0	24	9	0	68	1032
Peak 15-Min Flowrates	Northbound				Southbound				Eastbound				Westbound				Total	
	Left	Thru	Right	U	Left	Thru	Right	U	Left	Thru	Right	U	Left	Thru	Right	U		
All Vehicles	0	16	12	0	72	0	216	0	204	212	8	0	0	320	124	0	1184	
Heavy Trucks	0	4	0		4	0	4		4	40	0		0	20	0		76	
Pedestrians		12				12				4				0			28	
Bicycles	0	0	0		0	0	0		0	0	0		0	0	0		0	
Railroad																		
Stopped Buses																		

Comments:

LOCATION: Oak St -- SR-14
CITY/STATE: Cook, WA

QC JOB #: 139103125
DATE: Thu, Oct 06 2016

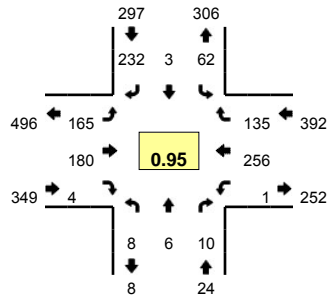

Peak-Hour: 3:35 PM -- 4:35 PM
Peak 15-Min: 4:00 PM -- 4:15 PM

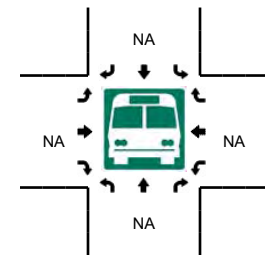
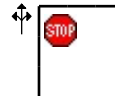
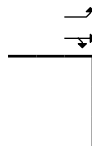
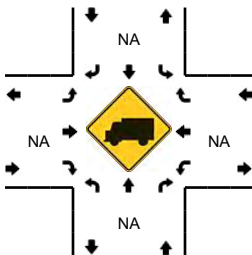
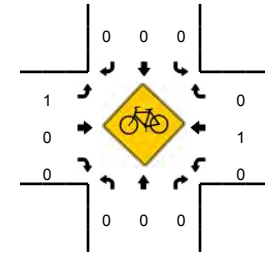
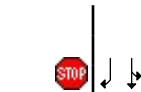
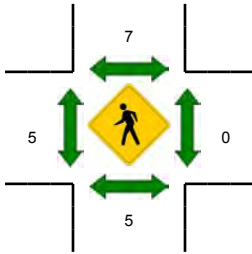
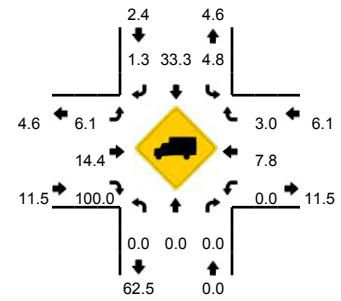

5-Min Count Period Beginning At	Oak St (Northbound)				Oak St (Southbound)				SR-14 (Eastbound)				SR-14 (Westbound)				Total	Hourly Totals
	Left	Thru	Right	U	Left	Thru	Right	U	Left	Thru	Right	U	Left	Thru	Right	U		
3:05 PM	0	0	0	0	7	0	30	0	6	14	0	0	0	21	9	0	87	898
3:10 PM	1	1	1	0	7	1	15	0	8	10	0	0	0	22	9	0	75	911
3:15 PM	0	0	0	0	5	0	16	0	7	17	0	0	0	15	7	0	67	892
3:20 PM	0	0	1	0	3	0	21	0	7	8	0	0	1	22	8	0	71	895
3:25 PM	0	0	0	0	6	0	22	0	11	20	0	0	0	12	12	0	83	919
3:30 PM	0	0	0	0	8	0	16	0	8	18	0	0	0	17	8	0	75	908
3:35 PM	0	0	1	0	7	0	26	0	16	18	0	0	0	24	5	0	97	938
3:40 PM	3	0	0	0	5	0	21	0	9	14	1	0	1	17	13	0	84	941
3:45 PM	0	0	0	0	9	0	20	0	9	13	0	0	0	19	9	0	79	953
3:50 PM	1	0	1	0	7	1	16	0	12	19	1	0	0	21	14	0	93	973
3:55 PM	0	0	1	0	2	0	19	0	17	15	0	0	0	17	13	0	84	985
4:00 PM	0	0	1	0	5	2	19	0	21	7	0	0	0	26	14	0	95	990
4:05 PM	0	1	1	0	4	0	12	0	21	20	0	0	0	27	9	0	95	998
4:10 PM	1	0	0	0	5	0	19	0	19	12	0	0	0	24	10	0	90	1013
4:15 PM	1	4	1	0	4	0	23	0	9	17	0	0	0	18	12	0	89	1035
4:20 PM	2	0	0	0	3	0	20	0	8	17	1	0	0	21	12	0	84	1048
4:25 PM	0	0	3	0	3	0	16	0	10	12	1	0	0	24	15	0	84	1049
4:30 PM	0	1	1	0	8	0	21	0	14	16	0	0	0	18	9	0	88	1062
4:35 PM	2	2	0	0	5	0	14	0	11	8	0	0	0	23	15	0	80	1045
4:40 PM	1	1	1	0	5	0	13	0	10	14	0	0	0	28	12	0	85	1046
4:45 PM	0	0	0	0	10	0	21	0	5	15	0	0	0	22	20	0	93	1060
4:50 PM	0	1	4	0	9	0	12	0	8	17	0	0	1	30	8	0	90	1057
4:55 PM	0	1	3	0	5	0	19	0	16	16	0	0	0	17	7	0	84	1057
5:00 PM	1	0	2	0	7	0	28	0	7	16	0	0	0	17	10	0	88	1050
Peak 15-Min Flowrates	Northbound				Southbound				Eastbound				Westbound				Total	
	Left	Thru	Right	U	Left	Thru	Right	U	Left	Thru	Right	U	Left	Thru	Right	U		
All Vehicles	4	4	8	0	56	8	200	0	244	156	0	0	0	308	132	0	1120	
Heavy Trucks	0	0	0	0	8	0	4	0	16	20	0	0	0	28	0	0	76	
Pedestrians		12				0				0				0			12	
Bicycles	0	0	0	0	0	0	0	0	0	0	0	0	0	1	0	0	1	
Railroad																		
Stopped Buses																		

Comments:

LOCATION: Maple St -- SR-14
CITY/STATE: Cook, WA

QC JOB #: 139103129
DATE: Tue, Oct 04 2016

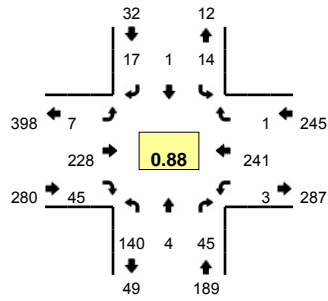

Peak-Hour: 3:45 PM -- 4:45 PM
Peak 15-Min: 4:05 PM -- 4:20 PM

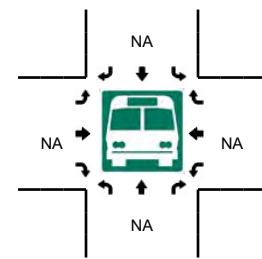
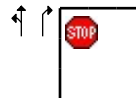
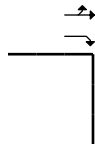
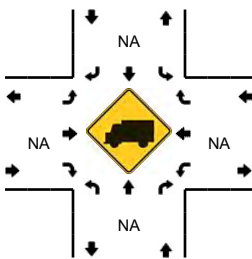
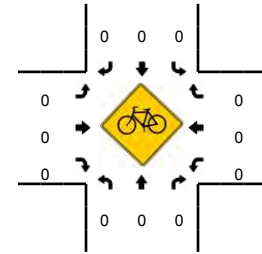
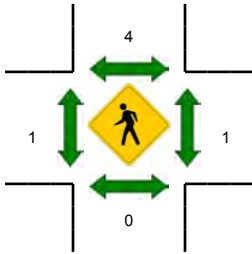
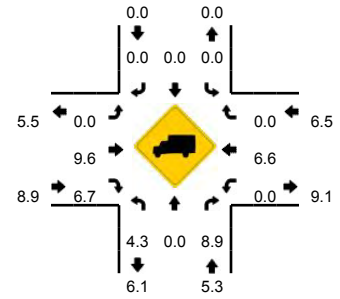

5-Min Count Period Beginning At	Maple St (Northbound)				Maple St (Southbound)				SR-14 (Eastbound)				SR-14 (Westbound)				Total	Hourly Totals
	Left	Thru	Right	U	Left	Thru	Right	U	Left	Thru	Right	U	Left	Thru	Right	U		
3:15 PM	5	0	2	0	2	0	0	0	0	18	2	0	1	19	0	0	49	569
3:20 PM	2	0	2	0	0	1	4	0	0	17	4	0	0	11	0	0	41	553
3:25 PM	3	0	1	0	0	1	3	0	2	23	2	0	1	16	0	0	52	569
3:30 PM	14	0	8	0	1	0	0	0	0	19	3	0	0	14	0	0	59	586
3:35 PM	22	0	3	0	1	0	0	0	0	21	1	0	0	18	0	0	66	590
3:40 PM	4	1	1	0	1	0	0	0	0	14	3	0	0	18	1	0	43	587
3:45 PM	12	0	2	0	1	0	0	0	0	23	3	0	1	25	0	0	67	600
3:50 PM	4	0	3	0	0	0	0	0	1	19	6	0	0	26	0	0	59	619
3:55 PM	8	1	4	0	2	0	2	0	0	17	8	0	0	19	0	0	61	625
4:00 PM	11	0	3	0	1	0	2	0	0	23	4	0	0	13	1	0	58	640
4:05 PM	11	0	5	0	1	1	5	0	1	25	3	0	2	17	0	0	71	666
4:10 PM	9	0	10	0	2	0	1	0	1	20	1	0	0	25	0	0	69	695
4:15 PM	27	0	8	0	2	0	0	0	0	17	4	0	0	14	0	0	72	718
4:20 PM	10	0	2	0	0	0	3	0	3	12	2	0	0	23	0	0	55	732
4:25 PM	8	0	2	0	0	0	1	0	0	7	4	0	0	20	0	0	42	722
4:30 PM	7	3	1	0	4	0	2	0	1	20	3	0	0	16	0	0	57	720
4:35 PM	15	0	2	0	1	0	1	0	0	27	3	0	0	15	0	0	64	718
4:40 PM	18	0	3	0	0	0	0	0	0	18	4	0	0	28	0	0	71	746
4:45 PM	10	0	5	0	1	0	1	0	0	20	3	0	0	23	0	0	63	742
4:50 PM	11	0	4	0	0	0	1	0	1	17	2	0	0	18	1	0	55	738
4:55 PM	9	0	3	0	1	0	0	0	0	20	1	0	0	22	0	0	56	733
5:00 PM	17	1	5	0	1	0	1	0	0	17	2	0	0	18	2	0	64	739
5:05 PM	17	0	3	0	2	2	2	0	1	17	1	0	0	12	0	0	57	725
5:10 PM	8	0	2	0	2	0	1	0	0	17	2	0	0	17	0	0	49	705
Peak 15-Min Flowrates	Northbound				Southbound				Eastbound				Westbound				Total	
	Left	Thru	Right	U	Left	Thru	Right	U	Left	Thru	Right	U	Left	Thru	Right	U		
All Vehicles	188	0	92	0	20	4	24	0	8	248	32	0	8	224	0	0	848	
Heavy Trucks	8	0	8		0	0	0		0	32	4		0	12	0		64	
Pedestrians	0				8				4				0				12	
Bicycles	0	0	0		0	0	0		0	0	0		0	0	0		0	
Railroad																		
Stopped Buses																		

Comments:

LOCATION: Maple St -- SR-14
CITY/STATE: Cook, WA

QC JOB #: 139103128
DATE: Thu, Oct 06 2016

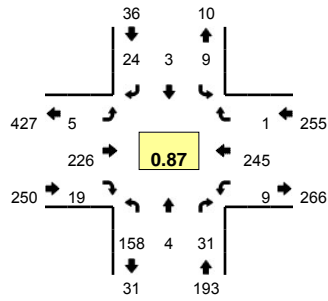

Peak-Hour: 3:55 PM -- 4:55 PM
Peak 15-Min: 4:40 PM -- 4:55 PM

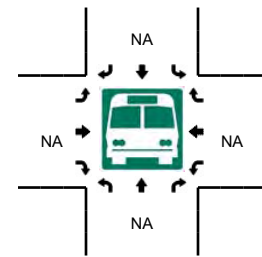
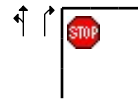
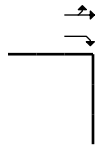
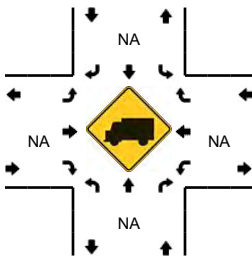
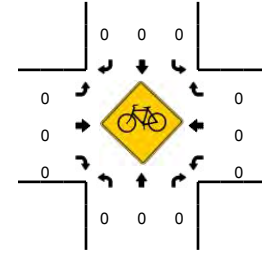
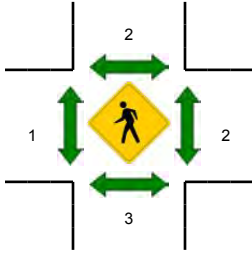
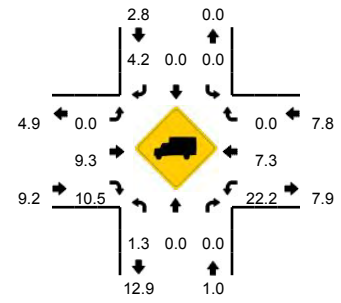

5-Min Count Period Beginning At	Maple St (Northbound)				Maple St (Southbound)				SR-14 (Eastbound)				SR-14 (Westbound)				Total	Hourly Totals
	Left	Thru	Right	U	Left	Thru	Right	U	Left	Thru	Right	U	Left	Thru	Right	U		
3:25 PM	6	0	1	0	1	2	1	0	2	16	7	0	1	15	0	0	52	647
3:30 PM	15	1	1	0	0	0	0	0	2	15	7	0	2	9	0	0	52	641
3:35 PM	14	1	4	0	4	1	3	0	0	26	2	0	0	13	0	0	68	661
3:40 PM	11	0	5	0	0	1	0	0	1	19	0	0	2	15	0	0	54	668
3:45 PM	9	0	3	0	0	0	0	0	0	14	4	0	1	18	0	0	49	674
3:50 PM	10	0	2	0	1	0	0	0	1	24	4	0	1	28	0	0	71	700
3:55 PM	7	0	2	0	1	0	1	0	1	16	0	0	0	23	0	0	51	694
4:00 PM	13	1	0	0	1	1	2	0	0	17	1	0	2	24	0	0	62	685
4:05 PM	12	0	4	0	0	0	2	0	1	23	1	0	1	21	0	0	65	692
4:10 PM	14	0	1	0	1	0	4	0	0	15	0	0	0	19	0	0	54	694
4:15 PM	11	0	2	0	0	0	4	0	0	23	2	0	1	16	0	0	59	706
4:20 PM	12	1	2	0	0	1	1	0	0	14	5	0	1	20	0	0	57	694
4:25 PM	13	1	2	0	1	1	2	0	1	16	1	0	0	22	0	0	60	702
4:30 PM	11	0	5	0	1	0	3	0	2	17	3	0	0	14	0	0	56	706
4:35 PM	17	0	5	0	2	0	0	0	0	14	0	0	0	21	0	0	59	697
4:40 PM	19	1	3	0	1	0	3	0	0	20	2	0	0	17	1	0	67	710
4:45 PM	14	0	0	0	1	0	2	0	0	22	1	0	3	28	0	0	71	732
4:50 PM	15	0	5	0	0	0	0	0	0	29	3	0	1	20	0	0	73	734
4:55 PM	3	0	1	0	3	0	1	0	0	20	2	0	0	21	0	0	51	734
5:00 PM	10	0	3	0	3	0	1	0	2	20	2	0	0	14	0	0	55	727
5:05 PM	6	0	1	0	2	1	0	0	1	19	3	0	1	28	0	0	62	724
5:10 PM	5	0	3	0	0	0	3	0	0	27	2	0	0	14	0	0	54	724
5:15 PM	4	1	0	0	0	0	2	0	2	25	0	0	0	16	0	0	50	715
5:20 PM	14	0	6	0	0	0	0	0	0	21	0	0	3	15	0	0	59	717
Peak 15-Min Flowrates	Northbound				Southbound				Eastbound				Westbound				Total	
	Left	Thru	Right	U	Left	Thru	Right	U	Left	Thru	Right	U	Left	Thru	Right	U		
All Vehicles	192	4	32	0	8	0	20	0	0	284	24	0	16	260	4	0	844	
Heavy Trucks	0	0	0	0	0	0	0	0	0	8	0	0	8	16	0	0	32	
Pedestrians	0	0	0	0	0	0	0	0	0	0	0	0	0	0	0	0	0	
Bicycles	0	0	0	0	0	0	0	0	0	0	0	0	0	0	0	0	0	
Railroad																		
Stopped Buses																		

Comments:

LOCATION: SR-14 east of SR-141 Alt. SPECIFIC LOCATION: SR-14 east of SR-141 Alt. CITY/STATE: Klickitat, WA							QC JOB #: 13910316 DIRECTION: EB DATE: Oct 04 2016 - Oct 06 2016			
Start Time	Mon 04-Oct-16	Tue 05-Oct-16	Wed 06-Oct-16	Thu 06-Oct-16	Fri	Average Weekday Hourly Traffic	Sat	Sun	Average Week Hourly Traffic	Average Week Profile
12:00 AM		6	7	4		6			6	
1:00 AM		8	10	3		7			7	
2:00 AM		13	12	8		11			11	
3:00 AM		14	19	16		16			16	
4:00 AM		47	48	45		47			47	
5:00 AM		155	135	139		143			143	
6:00 AM		252	243	255		250			250	
7:00 AM		370	382	387		380			380	
8:00 AM		361	337	289		329			329	
9:00 AM		278	256	273		269			269	
10:00 AM		272	228	249		250			250	
11:00 AM		244	282	283		270			270	
12:00 PM		265	282	268		272			272	
1:00 PM		268	239	259		255			255	
2:00 PM		224	226	239		230			230	
3:00 PM		268	217	271		252			252	
4:00 PM		245	209	268		241			241	
5:00 PM		226	197	243		222			222	
6:00 PM		154	152	159		155			155	
7:00 PM		103	107	84		98			98	
8:00 PM		53	65	70		63			63	
9:00 PM		37	49	29		38			38	
10:00 PM		24	22	23		23			23	
11:00 PM		14	13	11		13			13	
Day Total		3901	3737	3875		3840			3840	
% Weekday Average		101.6%	97.3%	100.9%						
% Week Average		101.6%	97.3%	100.9%		100.0%				
AM Peak Volume		7:00 AM 370	7:00 AM 382	7:00 AM 387		7:00 AM 380			7:00 AM 380	
PM Peak Volume		1:00 PM 268	12:00 PM 282	3:00 PM 271		12:00 PM 272			12:00 PM 272	
<i>Comments:</i>										

LOCATION: SR-14 east of SR-141 Alt. **QC JOB #:** 13910316
SPECIFIC LOCATION: SR-14 east of SR-141 Alt. **DIRECTION:** WB
CITY/STATE: Klickitat, WA **DATE:** Oct 04 2016 - Oct 06 2016

Start Time	Mon 04-Oct-16	Tue 05-Oct-16	Wed 06-Oct-16	Thu 06-Oct-16	Fri	Average Weekday Hourly Traffic	Sat	Sun	Average Week Hourly Traffic	Average Week Profile
12:00 AM		14	24	12		17			17	
1:00 AM		12	13	9		11			11	
2:00 AM		9	10	9		9			9	
3:00 AM		6	12	6		8			8	
4:00 AM		12	16	13		14			14	
5:00 AM		47	36	36		40			40	
6:00 AM		97	76	75		83			83	
7:00 AM		132	115	150		132			132	
8:00 AM		157	152	123		144			144	
9:00 AM		168	151	181		167			167	
10:00 AM		183	172	199		185			185	
11:00 AM		239	187	219		215			215	
12:00 PM		251	225	242		239			239	
1:00 PM		256	282	263		267			267	
2:00 PM		282	242	284		269			269	
3:00 PM		368	380	382		377			377	
4:00 PM		468	388	422		426			426	
5:00 PM		434	373	392		400			400	
6:00 PM		231	255	245		244			244	
7:00 PM		177	131	163		157			157	
8:00 PM		118	129	132		126			126	
9:00 PM		97	88	91		92			92	
10:00 PM		54	53	45		51			51	
11:00 PM		31	36	44		37			37	
Day Total		3843	3546	3737		3710			3710	
% Weekday Average		103.6%	95.6%	100.7%						
% Week Average		103.6%	95.6%	100.7%		100.0%				
AM Peak		11:00 AM	11:00 AM	11:00 AM		11:00 AM			11:00 AM	
Volume		239	187	219		215			215	
PM Peak		4:00 PM	4:00 PM	4:00 PM		4:00 PM			4:00 PM	
Volume		468	388	422		426			426	

Comments:

LOCATION: SR-14 west of SR-141 Alt. SPECIFIC LOCATION: SR-14 west of SR-141 Alt. CITY/STATE: Skamania, WA							QC JOB #: 13910315 DIRECTION: EB DATE: Oct 04 2016 - Oct 06 2016			
Start Time	Mon 04-Oct-16	Tue 05-Oct-16	Wed 06-Oct-16	Thu 06-Oct-16	Fri	Average Weekday Hourly Traffic	Sat	Sun	Average Week Hourly Traffic	Average Week Profile
12:00 AM		6	7	4		6			6	
1:00 AM		8	9	2		6			6	
2:00 AM		7	9	4		7			7	
3:00 AM		9	18	14		14			14	
4:00 AM		30	27	30		29			29	
5:00 AM		89	83	81		84			84	
6:00 AM		161	157	169		162			162	
7:00 AM		279	299	280		286			286	
8:00 AM		260	243	217		240			240	
9:00 AM		195	184	197		192			192	
10:00 AM		197	176	183		185			185	
11:00 AM		188	207	224		206			206	
12:00 PM		194	234	222		217			217	
1:00 PM		205	195	191		197			197	
2:00 PM		169	188	202		186			186	
3:00 PM		206	163	225		198			198	
4:00 PM		212	164	222		199			199	
5:00 PM		197	172	195		188			188	
6:00 PM		129	137	119		128			128	
7:00 PM		85	87	77		83			83	
8:00 PM		45	49	64		53			53	
9:00 PM		28	39	27		31			31	
10:00 PM		22	21	19		21			21	
11:00 PM		14	11	11		12			12	
Day Total		2935	2879	2979		2930			2930	
% Weekday Average		100.2%	98.3%	101.7%						
% Week Average		100.2%	98.3%	101.7%		100.0%				
AM Peak Volume		7:00 AM 279	7:00 AM 299	7:00 AM 280		7:00 AM 286			7:00 AM 286	
PM Peak Volume		4:00 PM 212	12:00 PM 234	3:00 PM 225		12:00 PM 217			12:00 PM 217	
<i>Comments:</i>										

LOCATION: SR-14 west of SR-141 Alt. SPECIFIC LOCATION: SR-14 west of SR-141 Alt. CITY/STATE: Skamania, WA							QC JOB #: 13910315 DIRECTION: WB DATE: Oct 04 2016 - Oct 06 2016			
Start Time	Mon 04-Oct-16	Tue 05-Oct-16	Wed 06-Oct-16	Thu 06-Oct-16	Fri	Average Weekday Hourly Traffic	Sat	Sun	Average Week Hourly Traffic	Average Week Profile
12:00 AM		9	17	9		12			12	
1:00 AM		8	10	6		8			8	
2:00 AM		6	8	9		8			8	
3:00 AM		5	9	5		6			6	
4:00 AM		13	19	14		15			15	
5:00 AM		52	41	44		46			46	
6:00 AM		89	81	64		78			78	
7:00 AM		112	106	137		118			118	
8:00 AM		140	126	119		128			128	
9:00 AM		133	126	143		134			134	
10:00 AM		164	141	154		153			153	
11:00 AM		186	158	181		175			175	
12:00 PM		200	201	225		209			209	
1:00 PM		198	226	230		218			218	
2:00 PM		226	207	220		218			218	
3:00 PM		295	298	315		303			303	
4:00 PM		352	287	318		319			319	
5:00 PM		334	269	303		302			302	
6:00 PM		177	190	192		186			186	
7:00 PM		119	98	121		113			113	
8:00 PM		77	85	91		84			84	
9:00 PM		62	70	57		63			63	
10:00 PM		32	39	33		35			35	
11:00 PM		19	22	33		25			25	
Day Total		3008	2834	3023		2956			2956	
% Weekday Average		101.8%	95.9%	102.3%						
% Week Average		101.8%	95.9%	102.3%		100.0%				
AM Peak		11:00 AM	11:00 AM	11:00 AM		11:00 AM			11:00 AM	
Volume		186	158	181		175			175	
PM Peak		4:00 PM	3:00 PM	4:00 PM		4:00 PM			4:00 PM	
Volume		352	298	318		319			319	
<i>Comments:</i>										

LOCATION: SR-14 btwn Walnut St & Alder St SPECIFIC LOCATION: SR-14 btwn Walnut St & Alder St CITY/STATE: Cook, WA							QC JOB #: 13910312 DIRECTION: EB DATE: Oct 04 2016 - Oct 06 2016			
Start Time	Mon 04-Oct-16	Tue 05-Oct-16	Wed 06-Oct-16	Thu 06-Oct-16	Fri	Average Weekday Hourly Traffic	Sat	Sun	Average Week Hourly Traffic	Average Week Profile
12:00 AM		16	12	20		16			16	
1:00 AM		17	12	8		12			12	
2:00 AM		11	20	16		16			16	
3:00 AM		8	9	15		11			11	
4:00 AM		23	27	23		24			24	
5:00 AM		103	89	80		91			91	
6:00 AM		166	171	163		167			167	
7:00 AM		251	254	243		249			249	
8:00 AM		227	260	218		235			235	
9:00 AM		213	237	228		226			226	
10:00 AM		229	221	203		218			218	
11:00 AM		324	327	347		333			333	
12:00 PM		315	286	283		295			295	
1:00 PM		292	264	265		274			274	
2:00 PM		283	298	248		276			276	
3:00 PM		298	336	332		322			322	
4:00 PM		370	318	343		344			344	
5:00 PM		294	238	292		275			275	
6:00 PM		159	165	185		170			170	
7:00 PM		110	133	120		121			121	
8:00 PM		73	89	84		82			82	
9:00 PM		65	56	52		58			58	
10:00 PM		39	41	39		40			40	
11:00 PM		31	31	29		30			30	
Day Total		3917	3894	3836		3885			3885	
% Weekday Average		100.8%	100.2%	98.7%						
% Week Average		100.8%	100.2%	98.7%		100.0%				
AM Peak Volume		11:00 AM 324	11:00 AM 327	11:00 AM 347		11:00 AM 333			11:00 AM 333	
PM Peak Volume		4:00 PM 370	3:00 PM 336	4:00 PM 343		4:00 PM 344			4:00 PM 344	
<i>Comments:</i>										

LOCATION: SR-14 btwn Walnut St & Alder St SPECIFIC LOCATION: SR-14 btwn Walnut St & Alder St CITY/STATE: Cook, WA										QC JOB #: 13910312 DIRECTION: WB DATE: Oct 04 2016 - Oct 06 2016
Start Time	Mon 04-Oct-16	Tue 05-Oct-16	Wed 06-Oct-16	Thu 06-Oct-16	Fri	Average Weekday Hourly Traffic	Sat	Sun	Average Week Hourly Traffic	Average Week Profile
12:00 AM		6	16	15		12			12	
1:00 AM		10	7	7		8			8	
2:00 AM		15	18	17		17			17	
3:00 AM		7	22	12		14			14	
4:00 AM		49	44	50		48			48	
5:00 AM		170	138	154		154			154	
6:00 AM		349	331	338		339			339	
7:00 AM		423	388	409		407			407	
8:00 AM		460	433	428		440			440	
9:00 AM		364	373	387		375			375	
10:00 AM		389	377	392		386			386	
11:00 AM		500	457	474		477			477	
12:00 PM		493	457	510		487			487	
1:00 PM		458	468	434		453			453	
2:00 PM		433	436	439		436			436	
3:00 PM		543	496	503		514			514	
4:00 PM		572	542	561		558			558	
5:00 PM		515	483	478		492			492	
6:00 PM		294	270	364		309			309	
7:00 PM		204	154	190		183			183	
8:00 PM		138	131	123		131			131	
9:00 PM		74	86	76		79			79	
10:00 PM		39	55	40		45			45	
11:00 PM		24	18	39		27			27	
Day Total		6529	6200	6440		6391			6391	
% Weekday Average		102.2%	97.0%	100.8%						
% Week Average		102.2%	97.0%	100.8%		100.0%				
AM Peak Volume		11:00 AM 500	11:00 AM 457	11:00 AM 474		11:00 AM 477			11:00 AM 477	
PM Peak Volume		4:00 PM 572	4:00 PM 542	4:00 PM 561		4:00 PM 558			4:00 PM 558	
<i>Comments:</i>										

LOCATION: SR-14 east of city boundary (MP 67) **QC JOB #:** 13910309
SPECIFIC LOCATION: SR-14 east of city boundary (MP 67) **DIRECTION:** EB
CITY/STATE: Cook, WA **DATE:** Oct 04 2016 - Oct 06 2016

Start Time	Mon 04-Oct-16	Tue 05-Oct-16	Wed 06-Oct-16	Thu 06-Oct-16	Fri	Average Weekday Hourly Traffic	Sat	Sun	Average Week Hourly Traffic	Average Week Profile
12:00 AM		10	6	17		11			11	
1:00 AM		10	9	6		8			8	
2:00 AM		14	9	11		11			11	
3:00 AM		6	8	9		8			8	
4:00 AM		6	9	14		10			10	
5:00 AM		70	68	50		63			63	
6:00 AM		94	99	94		96			96	
7:00 AM		108	112	123		114			114	
8:00 AM		125	132	98		118			118	
9:00 AM		145	128	156		143			143	
10:00 AM		146	157	175		159			159	
11:00 AM		204	177	182		188			188	
12:00 PM		193	157	229		193			193	
1:00 PM		188	160	168		172			172	
2:00 PM		174	190	193		186			186	
3:00 PM		196	192	221		203			203	
4:00 PM		248	231	229		236			236	
5:00 PM		228	223	260		237			237	
6:00 PM		112	131	150		131			131	
7:00 PM		91	93	104		96			96	
8:00 PM		70	77	71		73			73	
9:00 PM		59	37	38		45			45	
10:00 PM		27	24	29		27			27	
11:00 PM		21	20	17		19			19	
Day Total		2545	2449	2644		2547			2547	
% Weekday Average		99.9%	96.2%	103.8%						
% Week Average		99.9%	96.2%	103.8%		100.0%				
AM Peak Volume		11:00 AM 204	11:00 AM 177	11:00 AM 182		11:00 AM 188			11:00 AM 188	
PM Peak Volume		4:00 PM 248	4:00 PM 231	5:00 PM 260		5:00 PM 237			5:00 PM 237	

Comments:

LOCATION: SR-14 east of city boundary (MP 67) SPECIFIC LOCATION: SR-14 east of city boundary (MP 67) CITY/STATE: Cook, WA						QC JOB #: 13910309 DIRECTION: WB DATE: Oct 04 2016 - Oct 06 2016				
Start Time	Mon 04-Oct-16	Tue 05-Oct-16	Wed 06-Oct-16	Thu 06-Oct-16	Fri	Average Weekday Hourly Traffic	Sat	Sun	Average Week Hourly Traffic	Average Week Profile
12:00 AM		6	11	7		8			8	
1:00 AM		6	2	2		3			3	
2:00 AM		4	3	7		5			5	
3:00 AM		4	12	7		8			8	
4:00 AM		22	31	35		29			29	
5:00 AM		88	71	67		75			75	
6:00 AM		152	152	144		149			149	
7:00 AM		216	207	213		212			212	
8:00 AM		178	164	164		169			169	
9:00 AM		151	167	154		157			157	
10:00 AM		149	149	148		149			149	
11:00 AM		148	144	171		154			154	
12:00 PM		198	170	170		179			179	
1:00 PM		169	141	211		174			174	
2:00 PM		185	188	201		191			191	
3:00 PM		195	182	192		190			190	
4:00 PM		181	185	194		187			187	
5:00 PM		190	159	173		174			174	
6:00 PM		113	105	107		108			108	
7:00 PM		74	59	71		68			68	
8:00 PM		36	37	40		38			38	
9:00 PM		35	34	30		33			33	
10:00 PM		18	22	14		18			18	
11:00 PM		9	12	12		11			11	
Day Total		2527	2407	2534		2489			2489	
% Weekday Average		101.5%	96.7%	101.8%						
% Week Average		101.5%	96.7%	101.8%		100.0%				
AM Peak Volume		7:00 AM 216	7:00 AM 207	7:00 AM 213		7:00 AM 212			7:00 AM 212	
PM Peak Volume		12:00 PM 198	2:00 PM 188	1:00 PM 211		2:00 PM 191			2:00 PM 191	
<i>Comments:</i>										

LOCATION: Dock Grade Rd -- SR-14
CITY/STATE: Klickitat, WA

QC JOB #: 14276040
DATE: Tue, Jul 18 2017

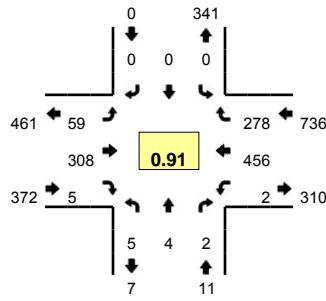

Peak-Hour: 4:40 PM -- 5:40 PM
Peak 15-Min: 5:10 PM -- 5:25 PM

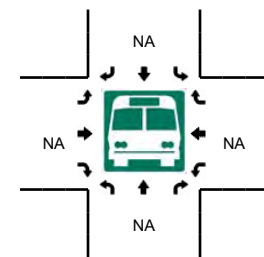
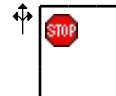
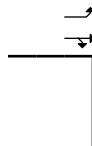
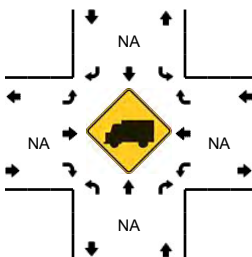
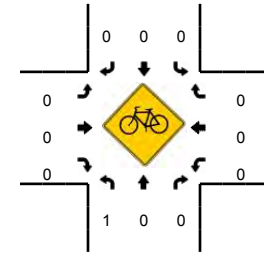
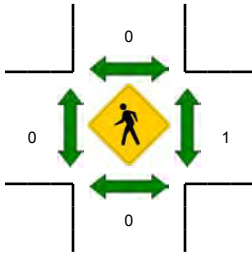
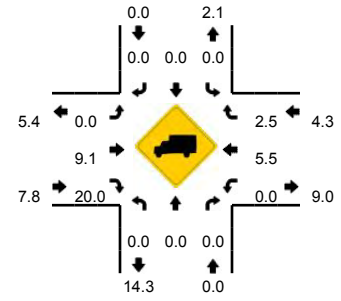

5-Min Count Period Beginning At	Dock Grade Rd (Northbound)				Dock Grade Rd (Southbound)				SR-14 (Eastbound)				SR-14 (Westbound)				Total	Hourly Totals	
	Left	Thru	Right	U	Left	Thru	Right	U	Left	Thru	Right	U	Left	Thru	Right	U			
4:00 PM	1	1	0	0	0	0	0	0	0	0	23	1	0	0	25	14	0	65	887
4:05 PM	1	0	0	0	0	0	0	0	0	5	27	0	0	0	35	23	0	91	916
4:10 PM	0	0	0	0	0	0	0	0	0	2	15	1	0	0	50	18	0	86	921
4:15 PM	0	0	0	0	0	0	0	0	0	2	27	0	0	0	38	18	0	85	930
4:20 PM	0	0	0	0	0	0	0	0	0	3	32	1	0	0	36	20	0	92	966
4:25 PM	0	0	0	0	0	0	0	0	0	3	26	1	0	0	32	18	0	80	964
4:30 PM	0	0	0	0	0	0	0	0	0	1	29	1	0	0	36	24	0	91	980
4:35 PM	1	0	0	0	0	0	0	0	0	3	23	0	0	0	32	21	0	80	983
4:40 PM	1	1	0	0	0	0	0	0	0	4	17	3	0	0	39	20	0	85	991
4:45 PM	1	0	0	0	0	0	0	0	0	3	31	0	0	0	37	17	0	89	1001
4:50 PM	0	0	0	0	0	0	0	0	0	6	21	0	0	1	42	28	0	98	1011
4:55 PM	1	0	0	0	0	0	0	0	0	8	28	0	0	0	38	20	0	95	1037
5:00 PM	0	0	0	0	0	0	0	0	0	1	26	0	0	0	38	25	0	90	1062
5:05 PM	0	0	0	0	0	0	0	0	0	8	33	0	0	0	37	18	0	96	1067
5:10 PM	0	0	0	0	0	0	0	0	0	3	17	0	0	1	38	31	0	90	1071
5:15 PM	2	0	0	0	0	0	0	0	0	6	28	0	0	0	48	31	0	115	1101
5:20 PM	0	1	0	0	0	0	0	0	0	1	29	0	0	0	45	25	0	101	1110
5:25 PM	0	0	0	0	0	0	0	0	0	7	24	1	0	0	28	24	0	84	1114
5:30 PM	0	2	2	0	0	0	0	0	0	3	17	0	0	0	32	22	0	78	1101
5:35 PM	0	0	0	0	0	0	0	0	0	9	37	1	0	0	34	17	0	98	1119
5:40 PM	0	0	0	0	0	0	0	0	0	3	21	3	0	0	36	14	0	77	1111
5:45 PM	0	0	0	0	0	0	0	0	0	3	22	1	0	0	30	25	0	81	1103
5:50 PM	1	0	0	0	0	0	0	0	0	4	21	1	0	0	35	23	0	85	1090
5:55 PM	0	0	0	0	0	0	0	0	0	6	26	1	0	1	30	25	0	89	1084
Peak 15-Min Flowrates	Northbound				Southbound				Eastbound				Westbound				Total		
	Left	Thru	Right	U	Left	Thru	Right	U	Left	Thru	Right	U	Left	Thru	Right	U			
All Vehicles	8	4	0	0	0	0	0	0	0	40	296	0	0	4	524	348	0	1224	
Heavy Trucks	0	0	0	0	0	0	0	0	0	0	44	0	0	0	24	8	0	76	
Pedestrians	0	0	0	0	0	0	0	0	0	0	0	0	0	4	0	0	0	4	
Bicycles	0	0	0	0	0	0	0	0	0	0	0	0	0	0	0	0	0	0	
Railroad																			
Stopped Buses																			

Comments:

LOCATION: Maple St -- SR-14
CITY/STATE: Cook, WA

QC JOB #: 14276036
DATE: Tue, Jul 18 2017

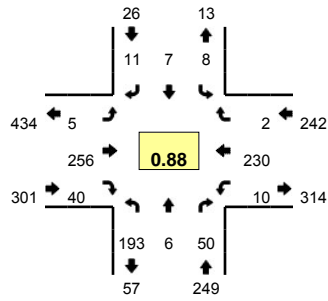

Peak-Hour: 4:05 PM -- 5:05 PM
Peak 15-Min: 4:30 PM -- 4:45 PM

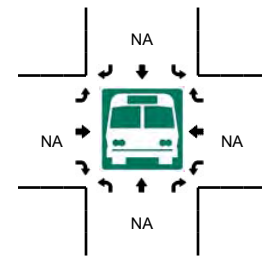
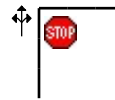
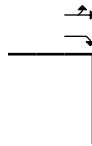
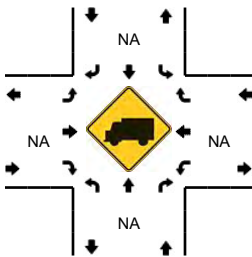
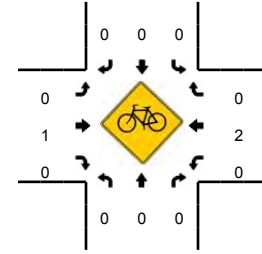
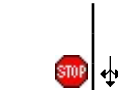
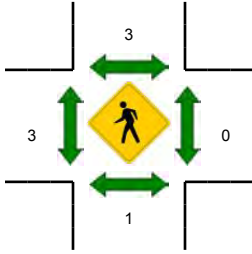
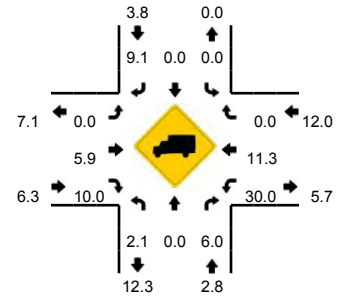

5-Min Count Period Beginning At	Maple St (Northbound)				Maple St (Southbound)				SR-14 (Eastbound)				SR-14 (Westbound)				Total	Hourly Totals
	Left	Thru	Right	U	Left	Thru	Right	U	Left	Thru	Right	U	Left	Thru	Right	U		
3:35 PM	19	0	9	0	0	3	0	0	0	15	4	0	1	26	0	0	77	703
3:40 PM	15	0	2	0	0	0	0	0	0	23	2	0	0	24	1	0	67	710
3:45 PM	10	0	0	0	1	0	1	0	1	15	2	0	0	11	0	0	41	700
3:50 PM	16	0	1	0	1	2	0	0	1	29	3	0	1	18	0	0	72	722
3:55 PM	9	0	3	0	1	0	0	0	0	13	3	0	0	15	1	0	45	698
4:00 PM	14	1	5	0	1	1	2	0	0	15	4	0	0	18	1	0	62	706
4:05 PM	16	1	3	0	1	0	2	0	3	27	4	0	2	17	0	0	76	727
4:10 PM	7	0	2	0	1	3	0	0	0	20	8	0	0	23	0	0	64	740
4:15 PM	12	0	3	0	0	1	1	0	0	21	5	0	2	16	0	0	61	742
4:20 PM	11	0	1	0	0	1	0	0	0	17	7	0	3	9	0	0	49	740
4:25 PM	14	0	1	0	1	0	3	0	0	17	6	0	1	24	0	0	67	757
4:30 PM	23	3	7	0	0	1	0	0	0	21	2	0	0	13	0	0	70	751
4:35 PM	23	0	7	0	1	0	1	0	0	26	2	0	2	17	1	0	80	754
4:40 PM	25	0	5	0	1	0	0	0	1	23	2	0	0	25	0	0	82	769
4:45 PM	12	1	5	0	0	0	2	0	1	15	1	0	0	24	0	0	61	789
4:50 PM	11	0	5	0	0	1	1	0	0	16	2	0	0	17	1	0	54	771
4:55 PM	23	1	5	0	2	0	0	0	0	16	0	0	0	18	0	0	65	791
5:00 PM	16	0	6	0	1	0	1	0	0	37	1	0	0	27	0	0	89	818
5:05 PM	18	0	0	0	1	0	3	0	0	18	2	0	0	24	0	0	66	808
5:10 PM	11	0	3	0	1	0	0	0	2	22	2	0	0	10	0	0	51	795
5:15 PM	11	0	1	0	2	1	1	0	0	22	1	0	0	19	0	0	58	792
5:20 PM	5	0	0	0	0	0	1	0	2	23	0	0	0	20	0	0	51	794
5:25 PM	8	2	4	0	0	0	4	0	0	20	0	0	0	18	0	0	56	783
5:30 PM	9	0	0	0	0	0	1	0	1	12	2	1	0	27	0	0	53	766
Peak 15-Min Flowrates	Northbound				Southbound				Eastbound				Westbound				Total	
	Left	Thru	Right	U	Left	Thru	Right	U	Left	Thru	Right	U	Left	Thru	Right	U		
All Vehicles	284	12	76	0	8	4	4	0	4	280	24	0	8	220	4	0	928	
Heavy Trucks	4	0	8		0	0	0		0	16	0		4	20	0		52	
Pedestrians	0				0				0	4			0	0			4	
Bicycles	0	0	0		0	0	0		0	0	0		0	0	0		0	
Railroad																		
Stopped Buses																		

Comments:

LOCATION: Ash St -- SR-14
CITY/STATE: Cook, WA

QC JOB #: 14276038
DATE: Tue, Jul 18 2017

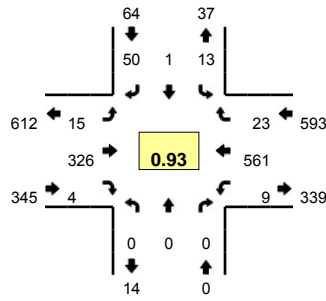

Peak-Hour: 4:25 PM -- 5:25 PM
Peak 15-Min: 4:55 PM -- 5:10 PM

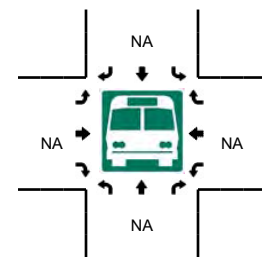
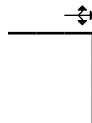
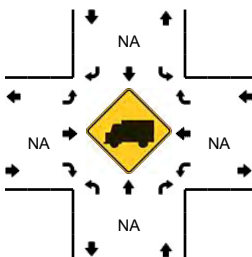
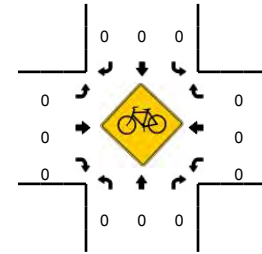
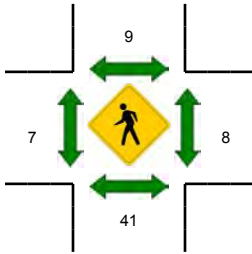
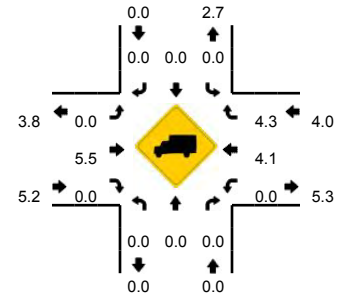

5-Min Count Period Beginning At	Ash St (Northbound)				Ash St (Southbound)				SR-14 (Eastbound)				SR-14 (Westbound)				Total	Hourly Totals
	Left	Thru	Right	U	Left	Thru	Right	U	Left	Thru	Right	U	Left	Thru	Right	U		
3:55 PM	0	0	0	0	0	0	7	0	2	19	0	0	2	29	1	1	61	939
4:00 PM	0	0	0	0	1	0	5	0	1	27	1	0	0	34	2	0	71	932
4:05 PM	0	0	0	0	0	0	6	0	4	33	0	0	0	49	0	0	92	956
4:10 PM	0	0	0	0	1	0	1	0	2	20	0	0	1	37	2	0	64	939
4:15 PM	0	0	0	0	2	0	5	0	0	29	0	0	1	36	1	0	74	939
4:20 PM	0	0	0	0	0	0	3	0	0	27	1	0	0	35	1	0	67	937
4:25 PM	0	0	0	0	2	1	4	0	0	23	1	0	0	48	3	0	82	937
4:30 PM	0	0	0	0	0	0	4	0	3	30	1	0	0	42	0	0	80	942
4:35 PM	0	0	0	0	3	0	4	0	0	22	0	0	3	43	3	0	78	929
4:40 PM	0	0	0	0	3	0	5	0	2	27	0	1	1	52	1	0	92	927
4:45 PM	0	0	0	0	1	0	4	0	2	23	1	0	1	51	2	0	85	936
4:50 PM	0	0	0	0	1	0	6	0	1	26	0	0	0	41	4	0	79	925
4:55 PM	0	0	0	0	1	0	4	0	1	23	0	0	0	53	2	0	84	948
5:00 PM	0	0	0	0	2	0	4	0	1	38	0	0	2	54	2	0	103	980
5:05 PM	0	0	0	0	0	0	5	0	1	22	1	0	1	51	1	0	82	970
5:10 PM	0	0	0	0	0	0	3	0	1	35	0	0	0	39	1	0	79	985
5:15 PM	0	0	0	0	0	0	3	0	1	35	0	0	0	40	1	0	80	991
5:20 PM	0	0	0	0	0	0	4	0	1	22	0	0	1	47	3	0	78	1002
5:25 PM	0	0	0	0	2	0	3	0	2	29	0	0	0	28	2	0	66	986
5:30 PM	0	0	0	0	0	0	3	0	1	20	1	0	0	40	1	0	66	972
5:35 PM	0	0	0	0	1	1	10	0	0	25	0	0	0	28	0	0	65	959
5:40 PM	0	0	0	0	0	0	5	0	3	24	0	0	0	39	2	0	73	940
5:45 PM	0	0	0	0	0	0	3	0	0	22	0	0	0	42	2	0	69	924
5:50 PM	0	0	0	0	0	0	2	0	2	25	0	0	1	32	2	0	64	909
Peak 15-Min Flowrates	Northbound				Southbound				Eastbound				Westbound				Total	
	Left	Thru	Right	U	Left	Thru	Right	U	Left	Thru	Right	U	Left	Thru	Right	U		
All Vehicles	0	0	0	0	12	0	52	0	12	332	4	0	12	632	20	0	1076	
Heavy Trucks	0	0	0	0	0	0	0	0	0	16	0	0	0	36	4	0	56	
Pedestrians		20				4				0				0			24	
Bicycles	0	0	0	0	0	0	0	0	0	0	0	0	0	0	0	0	0	
Railroad																	0	
Stopped Buses																	0	

Comments:

LOCATION: Walnut St -- SR-14
CITY/STATE: Cook, WA

QC JOB #: 14276032
DATE: Tue, Jul 18 2017

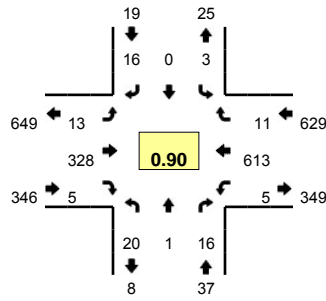

Peak-Hour: 4:25 PM -- 5:25 PM
Peak 15-Min: 4:55 PM -- 5:10 PM

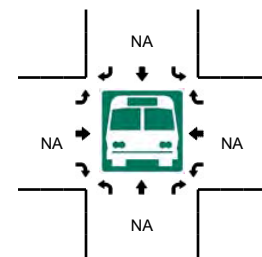
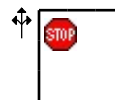
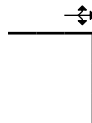
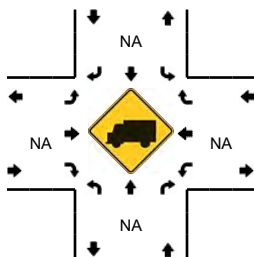
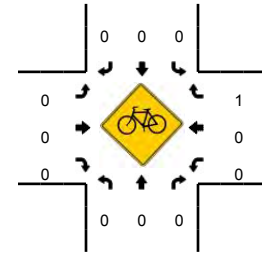
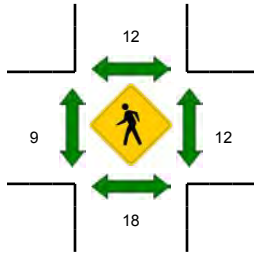
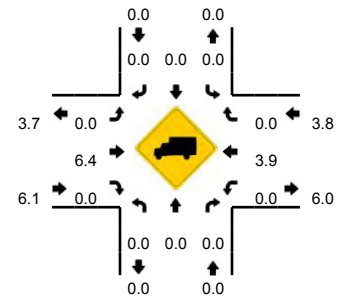

5-Min Count Period Beginning At	Walnut St (Northbound)				Walnut St (Southbound)				SR-14 (Eastbound)				SR-14 (Westbound)				Total	Hourly Totals
	Left	Thru	Right	U	Left	Thru	Right	U	Left	Thru	Right	U	Left	Thru	Right	U		
3:55 PM	0	0	1	0	0	0	4	0	0	22	0	0	0	36	1	0	64	985
4:00 PM	3	0	1	0	1	0	2	0	4	33	1	0	1	34	2	0	82	978
4:05 PM	2	0	0	0	0	0	2	0	0	33	1	0	0	59	0	0	97	1000
4:10 PM	1	0	0	0	0	0	0	0	0	23	1	0	0	37	0	0	62	973
4:15 PM	2	0	0	0	1	0	1	0	2	31	1	0	0	40	3	0	81	984
4:20 PM	1	0	1	0	1	0	0	0	0	23	1	0	0	37	0	0	64	973
4:25 PM	1	0	1	0	0	0	2	0	2	28	0	0	1	47	0	0	82	978
4:30 PM	7	0	3	0	0	0	2	0	1	24	0	0	0	48	1	0	86	979
4:35 PM	1	0	0	0	0	0	0	0	1	25	1	0	0	49	1	0	78	962
4:40 PM	0	0	3	0	0	0	0	0	1	28	2	0	1	62	3	0	100	970
4:45 PM	4	0	0	0	0	0	0	0	1	27	1	0	0	59	3	0	95	986
4:50 PM	0	0	2	0	0	0	0	0	3	22	0	0	0	45	1	0	73	964
4:55 PM	0	0	3	0	2	0	3	0	0	27	0	0	0	61	0	1	97	997
5:00 PM	4	0	2	0	0	0	0	0	2	29	0	0	1	56	0	0	94	1009
5:05 PM	1	0	1	0	0	0	3	0	0	27	0	0	0	62	0	0	94	1006
5:10 PM	0	0	0	0	0	0	2	0	1	37	0	0	0	45	1	0	86	1030
5:15 PM	2	1	1	0	1	0	2	0	0	22	1	0	0	44	0	1	75	1024
5:20 PM	0	0	0	0	0	0	2	0	1	32	0	0	0	35	1	0	71	1031
5:25 PM	2	0	2	0	0	0	0	0	2	20	0	0	0	44	1	0	71	1020
5:30 PM	0	0	0	0	1	0	0	0	2	19	0	0	1	39	1	0	63	997
5:35 PM	2	0	3	0	1	0	2	0	3	26	0	0	0	41	2	0	80	999
5:40 PM	0	0	2	0	0	0	3	0	1	21	0	0	0	49	1	0	77	976
5:45 PM	2	0	1	0	0	0	1	0	1	21	0	0	0	42	0	0	68	949
5:50 PM	0	0	1	0	1	0	1	0	0	28	1	0	0	28	1	0	61	937
Peak 15-Min Flowrates	Northbound				Southbound				Eastbound				Westbound				Total	
	Left	Thru	Right	U	Left	Thru	Right	U	Left	Thru	Right	U	Left	Thru	Right	U		
All Vehicles	20	0	24	0	8	0	24	0	8	332	0	0	4	716	0	4	1140	
Heavy Trucks	0	0	0		0	0	0		0	8	0		0	36	0		44	
Pedestrians		16				12				16				8			52	
Bicycles	0	0	0		0	0	0		0	0	0		0	0	1		1	
Railroad																		
Stopped Buses																		

Comments:

LOCATION: Oak St -- SR-14
CITY/STATE: Cook, WA

QC JOB #: 14276034
DATE: Tue, Jul 18 2017

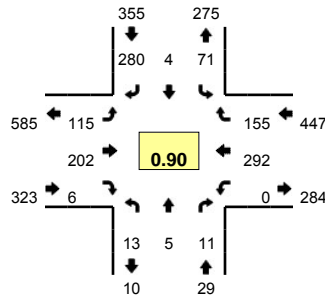

Peak-Hour: 4:20 PM -- 5:20 PM
Peak 15-Min: 4:55 PM -- 5:10 PM

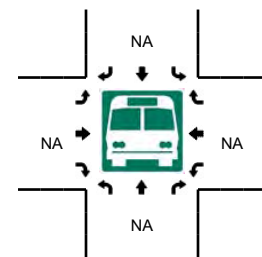
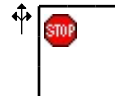
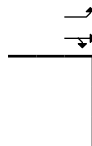
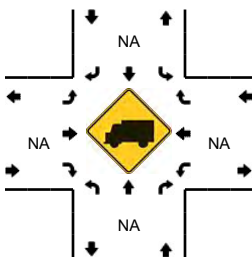
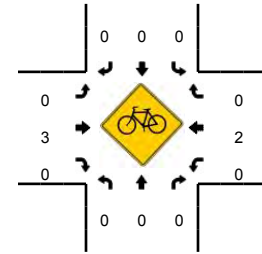
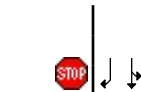
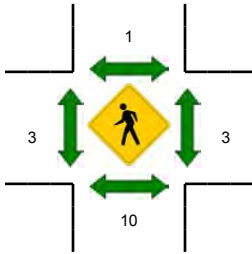
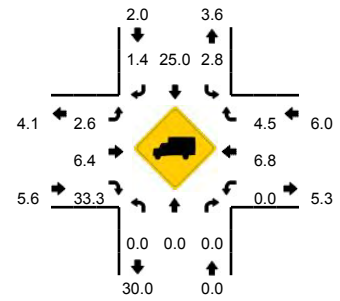

5-Min Count Period Beginning At	Oak St (Northbound)				Oak St (Southbound)				SR-14 (Eastbound)				SR-14 (Westbound)				Total	Hourly Totals
	Left	Thru	Right	U	Left	Thru	Right	U	Left	Thru	Right	U	Left	Thru	Right	U		
3:50 PM	0	0	1	0	8	1	17	0	15	24	0	0	1	23	11	0	101	1067
3:55 PM	0	0	1	0	4	0	19	0	9	10	0	0	0	14	10	0	67	1053
4:00 PM	0	3	4	0	7	0	12	0	11	12	1	0	0	23	13	0	86	1049
4:05 PM	0	1	0	0	4	0	27	0	7	28	0	0	0	23	13	0	103	1068
4:10 PM	2	1	1	0	10	0	11	0	4	17	0	1	0	27	6	0	80	1057
4:15 PM	0	1	0	0	7	0	18	0	11	20	0	0	0	18	10	0	85	1058
4:20 PM	1	0	0	0	11	0	23	0	13	15	0	0	0	10	10	0	83	1059
4:25 PM	1	0	0	0	5	0	19	0	7	17	0	0	0	30	11	0	90	1064
4:30 PM	0	1	2	0	4	1	16	0	9	17	0	0	0	28	12	0	90	1063
4:35 PM	1	0	3	0	10	0	20	0	11	14	0	0	0	26	15	0	100	1060
4:40 PM	1	2	0	0	6	0	25	0	6	18	2	0	0	32	17	0	109	1069
4:45 PM	4	0	1	0	2	0	28	0	10	14	1	0	0	23	14	0	97	1091
4:50 PM	0	1	0	0	4	0	22	0	10	14	1	0	0	23	7	0	82	1072
4:55 PM	0	0	2	0	2	0	23	0	9	14	1	0	0	30	16	0	97	1102
5:00 PM	2	1	2	0	10	2	28	0	9	26	1	0	0	29	15	0	125	1141
5:05 PM	1	0	0	0	5	1	23	0	10	15	0	0	0	28	17	0	100	1138
5:10 PM	1	0	0	0	5	0	29	0	12	23	0	0	0	12	9	0	91	1149
5:15 PM	1	0	1	0	7	0	24	0	9	15	0	0	0	21	12	0	90	1154
5:20 PM	1	1	1	0	3	0	14	0	9	20	0	0	0	15	13	0	77	1148
5:25 PM	1	0	1	0	2	0	17	0	7	20	0	0	0	22	7	0	77	1135
5:30 PM	0	2	0	0	3	1	15	0	8	10	0	0	1	24	15	0	79	1124
5:35 PM	0	1	0	0	6	0	15	0	10	18	0	0	0	15	8	0	73	1097
5:40 PM	2	1	0	0	8	1	23	0	10	14	0	0	0	15	8	0	82	1070
5:45 PM	1	1	0	0	7	1	20	0	6	17	0	0	0	24	10	0	87	1060
Peak 15-Min Flowrates	Northbound				Southbound				Eastbound				Westbound				Total	
	Left	Thru	Right	U	Left	Thru	Right	U	Left	Thru	Right	U	Left	Thru	Right	U		
All Vehicles	12	4	16	0	68	12	296	0	112	220	8	0	0	348	192	0	1288	
Heavy Trucks	0	0	0	0	0	4	0	0	0	12	0	0	0	36	4	0	56	
Pedestrians		12				4				12				0			28	
Bicycles	0	0	0	0	0	0	0	0	0	0	0	0	0	0	0	0	0	
Railroad																	0	
Stopped Buses																		

Comments:

LOCATION: Hood River Bridge -- SR-14
CITY/STATE: White Salmon, WA

QC JOB #: 14276030
DATE: Tue, Jul 18 2017

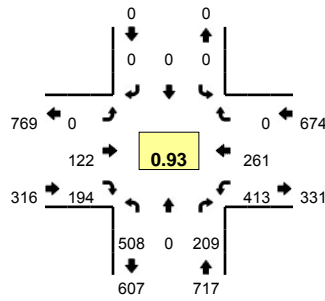

Peak-Hour: 4:30 PM -- 5:30 PM
Peak 15-Min: 5:10 PM -- 5:25 PM

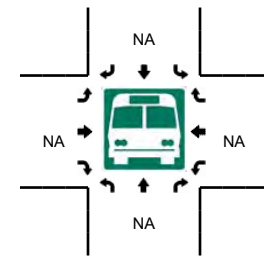
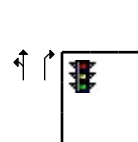
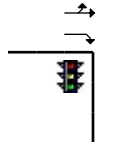
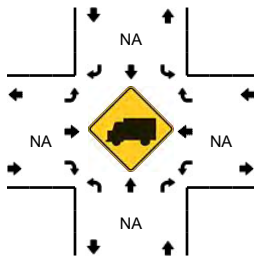
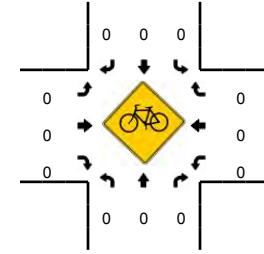
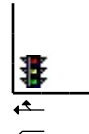
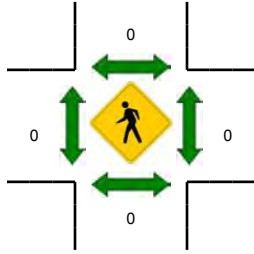
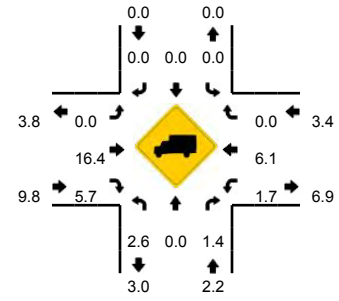

5-Min Count Period Beginning At	Hood River Bridge (Northbound)				Hood River Bridge (Southbound)				SR-14 (Eastbound)				SR-14 (Westbound)				Total	Hourly Totals
	Left	Thru	Right	U	Left	Thru	Right	U	Left	Thru	Right	U	Left	Thru	Right	U		
4:00 PM	31	0	19	0	0	0	0	0	0	13	10	0	27	9	0	0	109	1423
4:05 PM	42	0	13	0	0	0	0	0	0	16	9	0	34	20	0	0	134	1448
4:10 PM	42	0	29	0	0	0	0	0	0	5	13	0	27	23	0	0	139	1472
4:15 PM	40	0	13	0	0	0	0	0	0	6	22	0	29	17	0	0	127	1487
4:20 PM	35	0	23	0	0	0	0	0	0	14	15	0	30	21	0	0	138	1524
4:25 PM	37	0	17	0	0	0	0	0	0	10	17	0	28	16	0	0	125	1526
4:30 PM	41	0	15	0	0	0	0	0	0	12	20	0	29	23	0	0	140	1543
4:35 PM	31	0	20	0	0	0	0	0	0	15	12	0	32	19	0	0	129	1557
4:40 PM	46	0	20	0	0	0	0	0	0	8	7	0	22	20	0	0	123	1554
4:45 PM	35	0	10	0	0	0	0	0	0	10	20	0	40	23	0	0	138	1558
4:50 PM	41	0	20	0	0	0	0	0	0	7	10	0	42	23	0	0	143	1558
4:55 PM	40	0	18	0	0	0	0	0	0	12	23	0	32	26	0	0	151	1596
5:00 PM	44	0	16	0	0	0	0	0	0	11	12	0	41	16	0	0	140	1627
5:05 PM	35	0	25	0	0	0	0	0	0	14	19	0	32	26	0	0	151	1644
5:10 PM	50	0	24	0	0	0	0	0	0	8	11	0	33	19	0	0	145	1650
5:15 PM	54	0	12	0	0	0	0	0	0	4	16	0	49	25	0	0	160	1683
5:20 PM	54	0	17	0	0	0	0	0	0	12	25	0	28	19	0	0	155	1700
5:25 PM	37	0	12	0	0	0	0	0	0	9	19	0	33	22	0	0	132	1707
5:30 PM	35	0	15	0	0	0	0	0	0	7	10	0	26	15	0	0	108	1675
5:35 PM	33	0	20	0	0	0	0	0	0	6	28	0	21	23	0	0	131	1677
5:40 PM	35	0	22	0	0	0	0	0	0	7	18	0	38	15	0	0	135	1689
5:45 PM	46	0	11	0	0	0	0	0	0	5	13	0	35	12	0	0	122	1673
5:50 PM	32	0	15	0	0	0	0	0	0	15	14	0	28	19	0	0	123	1653
5:55 PM	47	0	21	0	0	0	0	0	0	7	17	0	24	15	0	0	131	1633
Peak 15-Min Flowrates	Northbound				Southbound				Eastbound				Westbound				Total	
	Left	Thru	Right	U	Left	Thru	Right	U	Left	Thru	Right	U	Left	Thru	Right	U		
All Vehicles	632	0	212	0	0	0	0	0	0	96	208	0	440	252	0	0	1840	
Heavy Trucks	12	0	4	0	0	0	0	0	0	28	16	0	4	16	0	0	80	
Pedestrians	0	0	0	0	0	0	0	0	0	0	0	0	0	0	0	0	0	
Bicycles	0	0	0	0	0	0	0	0	0	0	0	0	0	0	0	0	0	
Railroad																		
Stopped Buses																		

Comments:



Quality Counts

TRANSPORTATION DATA
COLLECTION SERVICES

Location: Maple St - Train Crossing Bike Count

Date: 7/18/2017

Site Code: 14276042

Start Time	Train Crossing	
	SBT	NBT
12:00 AM	0	0
12:15 AM	0	0
12:30 AM	0	0
12:45 AM	0	0
1:00 AM	0	0
1:15 AM	0	0
1:30 AM	0	0
1:45 AM	0	0
2:00 AM	0	0
2:15 AM	0	0
2:30 AM	0	0
2:45 AM	0	0
3:00 AM	0	0
3:15 AM	0	0
3:30 AM	0	0
3:45 AM	0	0
4:00 AM	0	0
4:15 AM	0	0
4:30 AM	1	0
4:45 AM	0	0
5:00 AM	0	0
5:15 AM	0	0
5:30 AM	0	0
5:45 AM	0	0
6:00 AM	0	0
6:15 AM	0	0
6:30 AM	0	0
6:45 AM	0	0
7:00 AM	0	0
7:15 AM	0	0
7:30 AM	0	0
7:45 AM	0	0
8:00 AM	0	0
8:15 AM	0	0
8:30 AM	0	0
8:45 AM	0	0
9:00 AM	0	0
9:15 AM	0	0
9:30 AM	0	0
9:45 AM	0	0
10:00 AM	0	0
10:15 AM	0	0
10:30 AM	0	0
10:45 AM	0	0
11:00 AM	0	0
11:15 AM	0	0
11:30 AM	0	0
11:45 AM	0	0

Start Time	Train Crossing	
	SBT	NBT
12:00 PM	0	0
12:15 PM	0	0
12:30 PM	0	0
12:45 PM	0	0
1:00 PM	0	0
1:15 PM	1	0
1:30 PM	0	1
1:45 PM	0	0
2:00 PM	0	0
2:15 PM	0	0
2:30 PM	0	0
2:45 PM	0	0
3:00 PM	0	0
3:15 PM	0	0
3:30 PM	0	0
3:45 PM	0	0
4:00 PM	0	0
4:15 PM	0	0
4:30 PM	0	0
4:45 PM	0	0
5:00 PM	0	0
5:15 PM	0	0
5:30 PM	0	1
5:45 PM	0	0
6:00 PM	0	0
6:15 PM	0	0
6:30 PM	0	0
6:45 PM	0	0
7:00 PM	0	0
7:15 PM	0	0
7:30 PM	1	0
7:45 PM	0	0
8:00 PM	0	0
8:15 PM	0	0
8:30 PM	0	0
8:45 PM	0	0
9:00 PM	1	0
9:15 PM	0	0
9:30 PM	0	0
9:45 PM	0	0
10:00 PM	0	0
10:15 PM	0	0
10:30 PM	0	0
10:45 PM	0	0
11:00 PM	0	0
11:15 PM	0	0
11:30 PM	0	0
11:45 PM	0	0
Total	4	2



Quality Counts

TRANSPORTATION DATA
COLLECTION SERVICES

Location: Maple St - Train Crossing Pedestrian Count

Date: 7/18/2017

Site Code: 14276042

Start Time	Train Crossing	
	SBT	NBT
12:00 AM	0	0
12:15 AM	0	0
12:30 AM	0	0
12:45 AM	0	0
1:00 AM	0	0
1:15 AM	0	0
1:30 AM	0	0
1:45 AM	0	0
2:00 AM	0	0
2:15 AM	0	0
2:30 AM	0	0
2:45 AM	0	0
3:00 AM	0	0
3:15 AM	0	0
3:30 AM	0	0
3:45 AM	0	0
4:00 AM	0	0
4:15 AM	0	0
4:30 AM	0	0
4:45 AM	0	0
5:00 AM	0	0
5:15 AM	0	0
5:30 AM	0	0
5:45 AM	0	0
6:00 AM	0	0
6:15 AM	0	0
6:30 AM	0	0
6:45 AM	0	0
7:00 AM	0	0
7:15 AM	1	0
7:30 AM	0	0
7:45 AM	0	1
8:00 AM	0	0
8:15 AM	0	0
8:30 AM	1	0
8:45 AM	1	0
9:00 AM	1	0
9:15 AM	1	0
9:30 AM	0	1
9:45 AM	0	1
10:00 AM	0	0
10:15 AM	0	0
10:30 AM	0	0
10:45 AM	0	1
11:00 AM	0	1
11:15 AM	1	0
11:30 AM	1	0
11:45 AM	3	0

Start Time	Train Crossing	
	SBT	NBT
12:00 PM	0	0
12:15 PM	0	3
12:30 PM	0	1
12:45 PM	1	0
1:00 PM	0	0
1:15 PM	0	0
1:30 PM	0	0
1:45 PM	0	0
2:00 PM	0	0
2:15 PM	0	0
2:30 PM	0	0
2:45 PM	0	0
3:00 PM	0	0
3:15 PM	0	0
3:30 PM	0	0
3:45 PM	0	0
4:00 PM	0	0
4:15 PM	0	0
4:30 PM	0	0
4:45 PM	0	2
5:00 PM	0	0
5:15 PM	0	0
5:30 PM	0	0
5:45 PM	0	0
6:00 PM	0	0
6:15 PM	0	0
6:30 PM	0	0
6:45 PM	0	0
7:00 PM	0	0
7:15 PM	1	0
7:30 PM	0	0
7:45 PM	0	0
8:00 PM	0	2
8:15 PM	2	1
8:30 PM	0	1
8:45 PM	0	0
9:00 PM	0	1
9:15 PM	0	0
9:30 PM	0	0
9:45 PM	0	0
10:00 PM	0	0
10:15 PM	0	0
10:30 PM	0	0
10:45 PM	0	0
11:00 PM	0	0
11:15 PM	0	0
11:30 PM	0	0
11:45 PM	0	0
Total	14	16



Quality Counts

TRANSPORTATION DATA
COLLECTION SERVICES

Location: Maple St - Train Crossing Heavy Truck Count

Date: 7/18/2017

Site Code: 14276042

Start Time	Train Crossing	
	SBT	NBT
12:00 AM	0	0
12:15 AM	0	0
12:30 AM	0	0
12:45 AM	0	0
1:00 AM	0	0
1:15 AM	0	0
1:30 AM	0	0
1:45 AM	0	0
2:00 AM	0	0
2:15 AM	0	0
2:30 AM	0	0
2:45 AM	0	0
3:00 AM	0	0
3:15 AM	0	0
3:30 AM	0	0
3:45 AM	0	0
4:00 AM	1	1
4:15 AM	0	0
4:30 AM	0	1
4:45 AM	0	2
5:00 AM	0	1
5:15 AM	1	0
5:30 AM	4	0
5:45 AM	2	2
6:00 AM	4	0
6:15 AM	3	5
6:30 AM	3	4
6:45 AM	4	4
7:00 AM	5	2
7:15 AM	5	4
7:30 AM	6	3
7:45 AM	3	4
8:00 AM	3	3
8:15 AM	3	8
8:30 AM	4	2
8:45 AM	7	2
9:00 AM	7	5
9:15 AM	5	5
9:30 AM	3	5
9:45 AM	3	8
10:00 AM	5	5
10:15 AM	6	6
10:30 AM	2	7
10:45 AM	4	3
11:00 AM	4	2
11:15 AM	2	3
11:30 AM	6	3
11:45 AM	3	6

Start Time	Train Crossing	
	SBT	NBT
12:00 PM	4	4
12:15 PM	5	5
12:30 PM	6	5
12:45 PM	7	5
1:00 PM	4	5
1:15 PM	3	3
1:30 PM	9	5
1:45 PM	3	5
2:00 PM	3	4
2:15 PM	4	2
2:30 PM	5	4
2:45 PM	2	7
3:00 PM	2	0
3:15 PM	3	4
3:30 PM	0	3
3:45 PM	2	0
4:00 PM	2	3
4:15 PM	3	0
4:30 PM	0	2
4:45 PM	0	0
5:00 PM	0	0
5:15 PM	0	0
5:30 PM	0	0
5:45 PM	0	0
6:00 PM	0	0
6:15 PM	0	0
6:30 PM	0	0
6:45 PM	0	0
7:00 PM	1	0
7:15 PM	0	0
7:30 PM	0	0
7:45 PM	0	0
8:00 PM	0	0
8:15 PM	0	0
8:30 PM	0	0
8:45 PM	0	0
9:00 PM	0	0
9:15 PM	0	0
9:30 PM	0	0
9:45 PM	0	0
10:00 PM	1	0
10:15 PM	0	0
10:30 PM	0	0
10:45 PM	0	1
11:00 PM	0	0
11:15 PM	0	0
11:30 PM	0	0
11:45 PM	0	0
Total	177	173



Quality Counts

TRANSPORTATION DATA
COLLECTION SERVICES

Location: Maple St - Train Crossing Vehicle Count

Date: 7/18/2017

Site Code: 14276042

Start Time	Train Crossing	
	SBT	NBT
12:00 AM	0	1
12:15 AM	0	0
12:30 AM	0	0
12:45 AM	0	1
1:00 AM	0	1
1:15 AM	1	1
1:30 AM	0	0
1:45 AM	0	2
2:00 AM	0	1
2:15 AM	0	1
2:30 AM	2	1
2:45 AM	0	1
3:00 AM	0	7
3:15 AM	0	1
3:30 AM	0	0
3:45 AM	0	0
4:00 AM	5	1
4:15 AM	2	1
4:30 AM	12	1
4:45 AM	17	2
5:00 AM	3	1
5:15 AM	10	0
5:30 AM	23	0
5:45 AM	49	2
6:00 AM	17	1
6:15 AM	21	6
6:30 AM	37	6
6:45 AM	64	12
7:00 AM	45	5
7:15 AM	44	9
7:30 AM	60	5
7:45 AM	46	10
8:00 AM	49	10
8:15 AM	36	21
8:30 AM	37	16
8:45 AM	36	10
9:00 AM	33	13
9:15 AM	19	13
9:30 AM	24	18
9:45 AM	21	24
10:00 AM	29	15
10:15 AM	16	15
10:30 AM	14	25
10:45 AM	16	34
11:00 AM	30	20
11:15 AM	16	20
11:30 AM	35	52
11:45 AM	19	42

Start Time	Train Crossing	
	SBT	NBT
12:00 PM	27	44
12:15 PM	39	35
12:30 PM	39	35
12:45 PM	41	30
1:00 PM	30	28
1:15 PM	24	18
1:30 PM	27	18
1:45 PM	24	30
2:00 PM	12	15
2:15 PM	22	14
2:30 PM	14	28
2:45 PM	12	31
3:00 PM	14	27
3:15 PM	9	33
3:30 PM	19	64
3:45 PM	12	38
4:00 PM	22	48
4:15 PM	26	44
4:30 PM	8	90
4:45 PM	6	61
5:00 PM	5	45
5:15 PM	1	29
5:30 PM	7	29
5:45 PM	8	21
6:00 PM	4	23
6:15 PM	5	17
6:30 PM	5	16
6:45 PM	3	5
7:00 PM	10	18
7:15 PM	1	1
7:30 PM	1	3
7:45 PM	3	2
8:00 PM	5	4
8:15 PM	2	5
8:30 PM	4	6
8:45 PM	3	5
9:00 PM	2	4
9:15 PM	3	3
9:30 PM	0	1
9:45 PM	2	2
10:00 PM	2	1
10:15 PM	1	5
10:30 PM	3	1
10:45 PM	2	2
11:00 PM	0	3
11:15 PM	0	2
11:30 PM	0	2
11:45 PM	2	0
Total	1399	1414

LOCATION: E Marina Way east of Recycling Dwy SPECIFIC LOCATION: E Marina Way east of Recycling Dwy CITY/STATE: Cook, WA							QC JOB #: 13937503 DIRECTION: EB DATE: Oct 04 2016 - Oct 06 2016			
Start Time	Mon 04-Oct-16	Tue 05-Oct-16	Wed 06-Oct-16	Thu 06-Oct-16	Fri	Average Weekday Hourly Traffic	Sat	Sun	Average Week Hourly Traffic	Average Week Profile
12:00 AM		2	2	0		1			1	
1:00 AM		0	1	1		1			1	
2:00 AM		1	1	1		1			1	
3:00 AM		1	2	0		1			1	
4:00 AM		24	17	21		21			21	
5:00 AM		26	36	36		33			33	
6:00 AM		94	96	95		95			95	
7:00 AM		177	168	127		157			157	
8:00 AM		135	139	126		133			133	
9:00 AM		56	72	78		69			69	
10:00 AM		59	54	43		52			52	
11:00 AM		71	55	64		63			63	
12:00 PM		98	114	102		105			105	
1:00 PM		66	66	69		67			67	
2:00 PM		53	59	43		52			52	
3:00 PM		43	51	43		46			46	
4:00 PM		38	29	24		30			30	
5:00 PM		23	13	26		21			21	
6:00 PM		9	10	23		14			14	
7:00 PM		8	6	4		6			6	
8:00 PM		1	6	1		3			3	
9:00 PM		3	4	5		4			4	
10:00 PM		2	4	5		4			4	
11:00 PM		2	1	2		2			2	
Day Total		992	1006	939		981			981	
% Weekday Average		101.1%	102.5%	95.7%						
% Week Average		101.1%	102.5%	95.7%		100.0%				
AM Peak		7:00 AM	7:00 AM	7:00 AM		7:00 AM			7:00 AM	
Volume		177	168	127		157			157	
PM Peak		12:00 PM	12:00 PM	12:00 PM		12:00 PM			12:00 PM	
Volume		98	114	102		105			105	
<i>Comments:</i>										

LOCATION: E Marina Way east of Recycling Dwy
SPECIFIC LOCATION: E Marina Way east of Recycling Dwy
CITY/STATE: Cook, WA

QC JOB #: 13937503
DIRECTION: WB
DATE: Oct 04 2016 - Oct 06 2016

Start Time	Mon 04-Oct-16	Tue 05-Oct-16	Wed 06-Oct-16	Thu 06-Oct-16	Fri	Average Weekday Hourly Traffic	Sat	Sun	Average Week Hourly Traffic	Average Week Profile
12:00 AM		2	3	1		2			2	
1:00 AM		2	1	0		1			1	
2:00 AM		3	3	3		3			3	
3:00 AM		1	0	0		0			0	
4:00 AM		1	1	1		1			1	
5:00 AM		2	4	3		3			3	
6:00 AM		7	10	14		10			10	
7:00 AM		21	20	24		22			22	
8:00 AM		30	33	29		31			31	
9:00 AM		44	56	35		45			45	
10:00 AM		63	50	53		55			55	
11:00 AM		112	98	95		102			102	
12:00 PM		87	101	95		94			94	
1:00 PM		76	105	56		79			79	
2:00 PM		57	61	56		58			58	
3:00 PM		96	100	111		102			102	
4:00 PM		167	156	177		167			167	
5:00 PM		131	129	80		113			113	
6:00 PM		44	41	53		46			46	
7:00 PM		13	18	11		14			14	
8:00 PM		9	12	3		8			8	
9:00 PM		3	3	5		4			4	
10:00 PM		3	5	2		3			3	
11:00 PM		0	3	9		4			4	
Day Total		974	1013	916		967			967	
% Weekday Average		100.7%	104.8%	94.7%						
% Week Average		100.7%	104.8%	94.7%		100.0%				
AM Peak		11:00 AM	11:00 AM	11:00 AM		11:00 AM			11:00 AM	
Volume		112	98	95		102			102	
PM Peak		4:00 PM	4:00 PM	4:00 PM		4:00 PM			4:00 PM	
Volume		167	156	177		167			167	

Comments:

LOCATION: E Marina Way east of Recycling Dwy SPECIFIC LOCATION: E Marina Way east of Recycling Dwy CITY/STATE: Cook, WA							QC JOB #: 13937503 DIRECTION: EB/WB DATE: Oct 04 2016 - Oct 06 2016			
Start Time	Mon 04-Oct-16	Tue 05-Oct-16	Wed 06-Oct-16	Thu 06-Oct-16	Fri	Average Weekday Hourly Traffic	Sat	Sun	Average Week Hourly Traffic	Average Week Profile
12:00 AM		4	5	1		3			3	
1:00 AM		2	2	1		2			2	
2:00 AM		4	4	4		4			4	
3:00 AM		2	2	0		1			1	
4:00 AM		25	18	22		22			22	
5:00 AM		28	40	39		36			36	
6:00 AM		101	106	109		105			105	
7:00 AM		198	188	151		179			179	
8:00 AM		165	172	155		164			164	
9:00 AM		100	128	113		114			114	
10:00 AM		122	104	96		107			107	
11:00 AM		183	153	159		165			165	
12:00 PM		185	215	197		199			199	
1:00 PM		142	171	125		146			146	
2:00 PM		110	120	99		110			110	
3:00 PM		139	151	154		148			148	
4:00 PM		205	185	201		197			197	
5:00 PM		154	142	106		134			134	
6:00 PM		53	51	76		60			60	
7:00 PM		21	24	15		20			20	
8:00 PM		10	18	4		11			11	
9:00 PM		6	7	10		8			8	
10:00 PM		5	9	7		7			7	
11:00 PM		2	4	11		6			6	
Day Total		1966	2019	1855		1948			1948	
% Weekday Average		100.9%	103.6%	95.2%						
% Week Average		100.9%	103.6%	95.2%		100.0%				
AM Peak		7:00 AM	7:00 AM	11:00 AM		7:00 AM			7:00 AM	
Volume		198	188	159		179			179	
PM Peak		4:00 PM	12:00 PM	4:00 PM		12:00 PM			12:00 PM	
Volume		205	215	201		199			199	
<i>Comments:</i>										

LOCATION: Recycling Dwy north of Marina Way **QC JOB #:** 13937504
SPECIFIC LOCATION: Recycling Dwy north of Marina Way **DIRECTION:** NB
CITY/STATE: Cook, WA **DATE:** Oct 04 2016 - Oct 06 2016

Start Time	Mon 04-Oct-16	Tue 05-Oct-16	Wed 06-Oct-16	Thu 06-Oct-16	Fri	Average Weekday Hourly Traffic	Sat	Sun	Average Week Hourly Traffic	Average Week Profile
12:00 AM		0	0	0		0			0	
1:00 AM		0	0	0		0			0	
2:00 AM		0	0	0		0			0	
3:00 AM		0	0	0		0			0	
4:00 AM		0	0	0		0			0	
5:00 AM		0	0	0		0			0	
6:00 AM		1	0	0		0			0	
7:00 AM		4	3	1		3			3	
8:00 AM		12	3	5		7			7	
9:00 AM		0	8	10		6			6	
10:00 AM		0	2	13		5			5	
11:00 AM		12	1	12		8			8	
12:00 PM		14	0	11		8			8	
1:00 PM		10	8	6		8			8	
2:00 PM		13	12	8		11			11	
3:00 PM		8	4	1		4			4	
4:00 PM		3	0	0		1			1	
5:00 PM		0	0	0		0			0	
6:00 PM		0	0	0		0			0	
7:00 PM		0	0	0		0			0	
8:00 PM		0	0	0		0			0	
9:00 PM		0	0	0		0			0	
10:00 PM		0	0	0		0			0	
11:00 PM		0	0	0		0			0	
Day Total		77	41	67		61			61	
% Weekday Average		126.2%	67.2%	109.8%						
% Week Average		126.2%	67.2%	109.8%		100.0%				
AM Peak		8:00 AM	9:00 AM	10:00 AM		11:00 AM			11:00 AM	
Volume		12	8	13		8			8	
PM Peak		12:00 PM	2:00 PM	12:00 PM		2:00 PM			2:00 PM	
Volume		14	12	11		11			11	

Comments:

LOCATION: Recycling Dwy north of Marina Way **QC JOB #:** 13937504
SPECIFIC LOCATION: Recycling Dwy north of Marina Way **DIRECTION:** SB
CITY/STATE: Cook, WA **DATE:** Oct 04 2016 - Oct 06 2016

Start Time	Mon 04-Oct-16	Tue 05-Oct-16	Wed 06-Oct-16	Thu 06-Oct-16	Fri	Average Weekday Hourly Traffic	Sat	Sun	Average Week Hourly Traffic	Average Week Profile
12:00 AM		0	0	0		0			0	
1:00 AM		0	0	0		0			0	
2:00 AM		0	0	0		0			0	
3:00 AM		0	0	0		0			0	
4:00 AM		0	0	0		0			0	
5:00 AM		0	0	0		0			0	
6:00 AM		0	0	0		0			0	
7:00 AM		4	6	2		4			4	
8:00 AM		12	4	7		8			8	
9:00 AM		1	8	10		6			6	
10:00 AM		0	4	9		4			4	
11:00 AM		11	0	13		8			8	
12:00 PM		11	0	11		7			7	
1:00 PM		9	7	7		8			8	
2:00 PM		14	7	9		10			10	
3:00 PM		9	8	1		6			6	
4:00 PM		2	1	0		1			1	
5:00 PM		0	0	0		0			0	
6:00 PM		0	0	0		0			0	
7:00 PM		0	0	0		0			0	
8:00 PM		0	0	0		0			0	
9:00 PM		0	0	0		0			0	
10:00 PM		0	0	0		0			0	
11:00 PM		0	0	0		0			0	
Day Total		73	45	69		62			62	
% Weekday Average		117.7%	72.6%	111.3%						
% Week Average		117.7%	72.6%	111.3%		100.0%				
AM Peak		8:00 AM	9:00 AM	11:00 AM		8:00 AM			8:00 AM	
Volume		12	8	13		8			8	
PM Peak		2:00 PM	3:00 PM	12:00 PM		2:00 PM			2:00 PM	
Volume		14	8	11		10			10	

Comments:

LOCATION: Recycling Dwy north of Marina Way SPECIFIC LOCATION: Recycling Dwy north of Marina Way CITY/STATE: Cook, WA						QC JOB #: 13937504 DIRECTION: NB/SB DATE: Oct 04 2016 - Oct 06 2016				
Start Time	Mon 04-Oct-16	Tue 05-Oct-16	Wed 06-Oct-16	Thu 06-Oct-16	Fri	Average Weekday Hourly Traffic	Sat	Sun	Average Week Hourly Traffic	Average Week Profile
12:00 AM		0	0	0		0			0	
1:00 AM		0	0	0		0			0	
2:00 AM		0	0	0		0			0	
3:00 AM		0	0	0		0			0	
4:00 AM		0	0	0		0			0	
5:00 AM		0	0	0		0			0	
6:00 AM		1	0	0		0			0	
7:00 AM		8	9	3		7			7	
8:00 AM		24	7	12		14			14	
9:00 AM		1	16	20		12			12	
10:00 AM		0	6	22		9			9	
11:00 AM		23	1	25		16			16	
12:00 PM		25	0	22		16			16	
1:00 PM		19	15	13		16			16	
2:00 PM		27	19	17		21			21	
3:00 PM		17	12	2		10			10	
4:00 PM		5	1	0		2			2	
5:00 PM		0	0	0		0			0	
6:00 PM		0	0	0		0			0	
7:00 PM		0	0	0		0			0	
8:00 PM		0	0	0		0			0	
9:00 PM		0	0	0		0			0	
10:00 PM		0	0	0		0			0	
11:00 PM		0	0	0		0			0	
Day Total		150	86	136		123			123	
% Weekday Average		122.0%	69.9%	110.6%						
% Week Average		122.0%	69.9%	110.6%		100.0%				
AM Peak		8:00 AM	9:00 AM	11:00 AM		11:00 AM			11:00 AM	
Volume		24	16	25		16			16	
PM Peak		2:00 PM	2:00 PM	12:00 PM		2:00 PM			2:00 PM	
Volume		27	19	22		21			21	
<i>Comments:</i>										

APPENDIX D – SYNCHRO OUTPUT SUMMARY

HCM 2010 TWSC
1: SR-14 & SR-141

Intersection

Int Delay, s/veh 3.6

Movement	EBL	EBT	WBT	WBR	SBL	SBR
Traffic Vol, veh/h	35	190	310	160	85	45
Future Vol, veh/h	35	190	310	160	85	45
Conflicting Peds, #/hr	0	0	0	0	0	0
Sign Control	Free	Free	Free	Free	Stop	Stop
RT Channelized	-	None	-	Free	-	None
Storage Length	-	-	-	-	0	-
Veh in Median Storage, #	-	0	0	-	0	-
Grade, %	-	0	0	-	0	-
Peak Hour Factor	86	86	87	87	88	88
Heavy Vehicles, %	4	11	5	2	6	7
Mvmt Flow	41	221	356	184	97	51

Major/Minor	Major1	Major2	Minor2
Conflicting Flow All	356	0	658
Stage 1	-	-	356
Stage 2	-	-	302
Critical Hdwy	4.14	-	6.46
Critical Hdwy Stg 1	-	-	5.46
Critical Hdwy Stg 2	-	-	5.46
Follow-up Hdwy	2.236	-	3.554
Pot Cap-1 Maneuver	1192	0	423
Stage 1	-	0	700
Stage 2	-	0	741
Platoon blocked, %	-	-	-
Mov Cap-1 Maneuver	1192	-	407
Mov Cap-2 Maneuver	-	-	407
Stage 1	-	-	700
Stage 2	-	-	712

Approach	EB	WB	SB
HCM Control Delay, s	1.3	0	16.1
HCM LOS			C

Minor Lane/Major Mvmt	EBL	EBT	WBT	SBLn1
Capacity (veh/h)	1192	-	-	472
HCM Lane V/C Ratio	0.034	-	-	0.313
HCM Control Delay (s)	8.1	0	-	16.1
HCM Lane LOS	A	A	-	C
HCM 95th %tile Q(veh)	0.1	-	-	1.3

HCM 2010 TWSC
 2: SR-14 & Dock Grade Rd

Intersection												
Int Delay, s/veh	0.9											

Movement	EBL	EBT	EBR	WBL	WBT	WBR	NBL	NBT	NBR	SBL	SBT	SBR
Traffic Vol, veh/h	45	225	5	5	460	265	10	5	5	0	0	0
Future Vol, veh/h	45	225	5	5	460	265	10	5	5	0	0	0
Conflicting Peds, #/hr	0	0	0	0	0	0	0	0	0	0	0	0
Sign Control	Free	Free	Free	Free	Free	Free	Stop	Stop	Stop	Stop	Stop	Stop
RT Channelized	-	-	None	-	-	None	-	-	None	-	-	None
Storage Length	125	-	-	125	-	325	-	-	-	-	-	-
Veh in Median Storage, #	-	0	-	-	0	-	-	0	-	-	0	-
Grade, %	-	0	-	-	0	-	-	0	-	-	0	-
Peak Hour Factor	86	86	86	91	91	91	67	67	67	92	92	92
Heavy Vehicles, %	1	14	8	0	21	5	0	0	0	2	2	2
Mvmt Flow	52	262	6	5	505	291	15	7	7	0	0	0

Major/Minor	Major1			Major2			Minor1		
Conflicting Flow All	505	0	0	267	0	0	885	885	265
Stage 1	-	-	-	-	-	-	369	369	-
Stage 2	-	-	-	-	-	-	516	516	-
Critical Hdwy	4.11	-	-	4.1	-	-	6.4	6.5	6.2
Critical Hdwy Stg 1	-	-	-	-	-	-	5.4	5.5	-
Critical Hdwy Stg 2	-	-	-	-	-	-	5.4	5.5	-
Follow-up Hdwy	2.209	-	-	2.2	-	-	3.5	4	3.3
Pot Cap-1 Maneuver	1065	-	-	1308	-	-	318	286	779
Stage 1	-	-	-	-	-	-	704	624	-
Stage 2	-	-	-	-	-	-	603	538	-
Platoon blocked, %	-	-	-	-	-	-	-	-	-
Mov Cap-1 Maneuver	1065	-	-	1308	-	-	301	0	779
Mov Cap-2 Maneuver	-	-	-	-	-	-	301	0	-
Stage 1	-	-	-	-	-	-	670	0	-
Stage 2	-	-	-	-	-	-	601	0	-

Approach	EB	WB	NB
HCM Control Delay, s	1.4	0.1	15.3
HCM LOS			C

Minor Lane/Major Mvmt	NBLn1	EBL	EBT	EBR	WBL	WBT	WBR
Capacity (veh/h)	378	1065	-	-	1308	-	-
HCM Lane V/C Ratio	0.079	0.049	-	-	0.004	-	-
HCM Control Delay (s)	15.3	8.6	-	-	7.8	-	-
HCM Lane LOS	C	A	-	-	A	-	-
HCM 95th %tile Q(veh)	0.3	0.2	-	-	0	-	-

HCM Signalized Intersection Capacity Analysis

3: Hood River Bridge & SR-14

	→	↘	↙	←	↖	↗
Movement	EBT	EBR	WBL	WBT	NBL	NBR
Lane Configurations	↑	↗	↘	↑	↘	↗
Traffic Volume (vph)	100	130	415	255	475	185
Future Volume (vph)	100	130	415	255	475	185
Ideal Flow (vphpl)	1900	1900	1900	1900	1900	1900
Total Lost time (s)	5.0	5.0	4.0	5.0	5.0	5.0
Lane Util. Factor	1.00	1.00	1.00	1.00	1.00	1.00
Frbp, ped/bikes	1.00	1.00	1.00	1.00	1.00	1.00
Flpb, ped/bikes	1.00	1.00	1.00	1.00	1.00	1.00
Frt	1.00	0.85	1.00	1.00	1.00	0.85
Flt Protected	1.00	1.00	0.95	1.00	0.95	1.00
Satd. Flow (prot)	1545	1509	1770	1792	1787	1553
Flt Permitted	1.00	1.00	0.95	1.00	0.95	1.00
Satd. Flow (perm)	1545	1509	1770	1792	1787	1553
Peak-hour factor, PHF	0.84	0.84	0.97	0.97	0.89	0.89
Adj. Flow (vph)	119	155	428	263	534	208
RTOR Reduction (vph)	0	13	0	0	0	54
Lane Group Flow (vph)	119	142	428	263	534	154
Confl. Peds. (#/hr)		1	1			1
Heavy Vehicles (%)	23%	7%	2%	6%	1%	4%
Turn Type	NA	pt+ov	Prot	NA	Prot	Prot
Protected Phases	2	2 8	1	6	8	8
Permitted Phases						
Actuated Green, G (s)	60.2	115.8	31.1	95.3	50.6	50.6
Effective Green, g (s)	60.2	115.8	31.1	95.3	50.6	50.6
Actuated g/C Ratio	0.39	0.74	0.20	0.61	0.32	0.32
Clearance Time (s)	5.0		4.0	5.0	5.0	5.0
Vehicle Extension (s)	3.0		3.0	3.0	3.0	3.0
Lane Grp Cap (vph)	596	1120	353	1095	580	504
v/s Ratio Prot	0.08	0.09	c0.24	c0.15	c0.30	0.10
v/s Ratio Perm						
v/c Ratio	0.20	0.13	1.21	0.24	0.92	0.31
Uniform Delay, d1	31.8	5.7	62.4	13.8	50.7	39.5
Progression Factor	1.00	1.00	1.00	1.00	1.00	1.00
Incremental Delay, d2	0.8	0.1	119.0	0.1	20.1	0.3
Delay (s)	32.6	5.7	181.4	13.9	70.8	39.8
Level of Service	C	A	F	B	E	D
Approach Delay (s)	17.4			117.6	62.1	
Approach LOS	B			F	E	
Intersection Summary						
HCM 2000 Control Delay			77.4		HCM 2000 Level of Service	E
HCM 2000 Volume to Capacity ratio			0.70			
Actuated Cycle Length (s)			155.9		Sum of lost time (s)	14.0
Intersection Capacity Utilization			64.3%		ICU Level of Service	C
Analysis Period (min)			15			

c Critical Lane Group

Queues

3: Hood River Bridge & SR-14

	→	↘	↙	←	↖	↗
Lane Group	EBT	EBR	WBL	WBT	NBL	NBR
Lane Group Flow (vph)	119	155	428	263	534	208
v/c Ratio	0.20	0.14	1.21	0.24	0.92	0.37
Control Delay	34.9	3.9	170.3	15.7	72.9	25.5
Queue Delay	0.0	0.0	0.0	0.0	0.0	0.0
Total Delay	34.9	3.9	170.3	15.7	72.9	25.5
Queue Length 50th (ft)	82	26	~544	122	524	98
Queue Length 95th (ft)	132	42	#809	193	676	168
Internal Link Dist (ft)	1219			2070	431	
Turn Bay Length (ft)		250	125			125
Base Capacity (vph)	596	1223	353	1094	689	648
Starvation Cap Reductn	0	0	0	0	0	0
Spillback Cap Reductn	0	0	0	0	0	0
Storage Cap Reductn	0	0	0	0	0	0
Reduced v/c Ratio	0.20	0.13	1.21	0.24	0.78	0.32

Intersection Summary

- ~ Volume exceeds capacity, queue is theoretically infinite.
Queue shown is maximum after two cycles.
- # 95th percentile volume exceeds capacity, queue may be longer.
Queue shown is maximum after two cycles.

HCM 2010 TWSC
4: Walnut St & SR-14

Intersection												
Int Delay, s/veh	2.7											

Movement	EBL	EBT	EBR	WBL	WBT	WBR	NBL	NBT	NBR	SBL	SBT	SBR
Traffic Vol, veh/h	10	310	5	10	570	15	25	5	30	5	5	15
Future Vol, veh/h	10	310	5	10	570	15	25	5	30	5	5	15
Conflicting Peds, #/hr	13	0	12	12	0	13	6	0	11	11	0	6
Sign Control	Free	Free	Free	Free	Free	Free	Stop	Stop	Stop	Stop	Stop	Stop
RT Channelized	-	-	None	-	-	None	-	-	None	-	-	None
Storage Length	-	-	-	-	-	-	-	-	-	-	-	-
Veh in Median Storage, #	-	0	-	-	0	-	-	0	-	-	0	-
Grade, %	-	0	-	-	0	-	-	0	-	-	0	-
Peak Hour Factor	81	81	81	92	92	92	65	65	65	73	73	73
Heavy Vehicles, %	0	8	8	5	4	4	2	0	0	0	0	3
Mvmt Flow	12	383	6	11	620	16	38	8	46	7	7	21

Major/Minor	Major1			Major2			Minor1			Minor2		
Conflicting Flow All	647	0	0	400	0	0	1095	1090	410	1108	1085	652
Stage 1	-	-	-	-	-	-	421	421	-	660	660	-
Stage 2	-	-	-	-	-	-	674	669	-	448	425	-
Critical Hdwy	4.1	-	-	4.15	-	-	7.12	6.5	6.2	7.1	6.5	6.23
Critical Hdwy Stg 1	-	-	-	-	-	-	6.12	5.5	-	6.1	5.5	-
Critical Hdwy Stg 2	-	-	-	-	-	-	6.12	5.5	-	6.1	5.5	-
Follow-up Hdwy	2.2	-	-	2.245	-	-	3.518	4	3.3	3.5	4	3.327
Pot Cap-1 Maneuver	948	-	-	1143	-	-	191	217	646	189	218	466
Stage 1	-	-	-	-	-	-	610	592	-	455	463	-
Stage 2	-	-	-	-	-	-	444	459	-	594	590	-
Platoon blocked, %	-	-	-	-	-	-	-	-	-	-	-	-
Mov Cap-1 Maneuver	936	-	-	1129	-	-	170	206	631	162	207	455
Mov Cap-2 Maneuver	-	-	-	-	-	-	170	206	-	162	207	-
Stage 1	-	-	-	-	-	-	594	576	-	443	451	-
Stage 2	-	-	-	-	-	-	406	447	-	528	574	-

Approach	EB	WB	NB	SB
HCM Control Delay, s	0.3	0.1	24.7	19.4
HCM LOS			C	C

Minor Lane/Major Mvmt	NBLn1	EBL	EBT	EBR	WBL	WBT	WBR	SBLn1
Capacity (veh/h)	274	936	-	-	1129	-	-	284
HCM Lane V/C Ratio	0.337	0.013	-	-	0.01	-	-	0.121
HCM Control Delay (s)	24.7	8.9	0	-	8.2	0	-	19.4
HCM Lane LOS	C	A	A	-	A	A	-	C
HCM 95th %tile Q(veh)	1.4	0	-	-	0	-	-	0.4

HCM 2010 TWSC
5: Ash St & SR-14

Intersection												
Int Delay, s/veh	1.8											

Movement	EBL	EBT	EBR	WBL	WBT	WBR	NBL	NBT	NBR	SBL	SBT	SBR
Traffic Vol, veh/h	15	320	5	5	530	10	0	0	0	15	0	60
Future Vol, veh/h	15	320	5	5	530	10	0	0	0	15	0	60
Conflicting Peds, #/hr	3	0	9	9	0	3	8	0	8	8	0	8
Sign Control	Free	Free	Free	Free	Free	Free	Stop	Stop	Stop	Stop	Stop	Stop
RT Channelized	-	-	None	-	-	None	-	-	None	-	-	None
Storage Length	-	-	-	-	-	-	-	-	-	-	-	-
Veh in Median Storage, #	-	0	-	-	0	-	-	0	-	-	0	-
Grade, %	-	0	-	-	0	-	-	0	-	-	0	-
Peak Hour Factor	90	90	90	88	88	88	92	92	92	73	73	73
Heavy Vehicles, %	7	6	0	0	5	0	2	2	2	8	0	0
Mvmt Flow	17	356	6	6	602	11	0	0	0	21	0	82

Major/Minor	Major1			Major2			Minor2		
Conflicting Flow All	622	0	0	361	0	0	1019	1021	625
Stage 1	-	-	-	-	-	-	627	627	-
Stage 2	-	-	-	-	-	-	392	394	-
Critical Hdwy	4.17	-	-	4.1	-	-	6.48	6.5	6.2
Critical Hdwy Stg 1	-	-	-	-	-	-	5.48	5.5	-
Critical Hdwy Stg 2	-	-	-	-	-	-	5.48	5.5	-
Follow-up Hdwy	2.263	-	-	2.2	-	-	3.572	4	3.3
Pot Cap-1 Maneuver	935	-	-	1209	-	-	256	238	488
Stage 1	-	-	-	-	-	-	521	479	-
Stage 2	-	-	-	-	-	-	670	609	-
Platoon blocked, %	-	-	-	-	-	-	-	-	-
Mov Cap-1 Maneuver	927	-	-	1199	-	-	244	0	480
Mov Cap-2 Maneuver	-	-	-	-	-	-	244	0	-
Stage 1	-	-	-	-	-	-	513	0	-
Stage 2	-	-	-	-	-	-	650	0	-

Approach	EB	WB	SB
HCM Control Delay, s	0.4	0.1	17
HCM LOS			C

Minor Lane/Major Mvmt	EBL	EBT	EBR	WBL	WBT	WBR	SBLn1
Capacity (veh/h)	927	-	-	1199	-	-	402
HCM Lane V/C Ratio	0.018	-	-	0.005	-	-	0.256
HCM Control Delay (s)	9	0	-	8	0	-	17
HCM Lane LOS	A	A	-	A	A	-	C
HCM 95th %tile Q(veh)	0.1	-	-	0	-	-	1

HCM 2010 TWSC
6: Oak St & SR-14

Intersection

Int Delay, s/veh 9.7

Movement	EBL	EBT	EBR	WBL	WBT	WBR	NBL	NBT	NBR	SBL	SBT	SBR
Traffic Vol, veh/h	145	190	5	5	285	145	10	15	15	75	0	250
Future Vol, veh/h	145	190	5	5	285	145	10	15	15	75	0	250
Conflicting Peds, #/hr	6	0	7	7	0	6	2	0	1	1	0	2
Sign Control	Free	Free	Free	Free	Free	Free	Stop	Stop	Stop	Stop	Stop	Stop
RT Channelized	-	-	None	-	-	None	-	-	None	-	-	None
Storage Length	100	-	-	-	-	-	-	-	-	-	-	75
Veh in Median Storage, #	-	0	-	-	0	-	-	0	-	-	0	-
Grade, %	-	0	-	-	0	-	-	0	-	-	0	-
Peak Hour Factor	79	79	79	90	90	90	83	83	83	81	81	81
Heavy Vehicles, %	3	12	50	0	7	2	13	4	0	5	0	1
Mvmt Flow	184	241	6	6	317	161	12	18	18	93	0	309

Major/Minor	Major1			Major2			Minor1			Minor2		
Conflicting Flow All	480	0	0	249	0	0	1023	1104	253	1041	1026	406
Stage 1	-	-	-	-	-	-	613	613	-	410	410	-
Stage 2	-	-	-	-	-	-	410	491	-	631	616	-
Critical Hdwy	4.13	-	-	4.1	-	-	7.23	6.54	6.2	7.15	6.5	6.21
Critical Hdwy Stg 1	-	-	-	-	-	-	6.23	5.54	-	6.15	5.5	-
Critical Hdwy Stg 2	-	-	-	-	-	-	6.23	5.54	-	6.15	5.5	-
Follow-up Hdwy	2.227	-	-	2.2	-	-	3.617	4.036	3.3	3.545	4	3.309
Pot Cap-1 Maneuver	1077	-	-	1328	-	-	204	209	791	205	237	647
Stage 1	-	-	-	-	-	-	461	480	-	613	599	-
Stage 2	-	-	-	-	-	-	597	545	-	464	485	-
Platoon blocked, %	-	-	-	-	-	-	-	-	-	-	-	-
Mov Cap-1 Maneuver	1070	-	-	1319	-	-	91	171	784	158	194	641
Mov Cap-2 Maneuver	-	-	-	-	-	-	91	171	-	158	194	-
Stage 1	-	-	-	-	-	-	381	397	-	507	594	-
Stage 2	-	-	-	-	-	-	306	541	-	356	401	-

Approach	EB		WB		NB		SB
HCM Control Delay, s	3.9		0.1		31.2		25
HCM LOS					D		D

Minor Lane/Major Mvmt	NBLn1	EBL	EBT	EBR	WBL	WBT	WBR	SBLn1	SBLn2
Capacity (veh/h)	185	1070	-	-	1319	-	-	158	641
HCM Lane V/C Ratio	0.261	0.172	-	-	0.004	-	-	0.586	0.482
HCM Control Delay (s)	31.2	9.1	-	-	7.7	0	-	55.8	15.7
HCM Lane LOS	D	A	-	-	A	A	-	F	C
HCM 95th %tile Q(veh)	1	0.6	-	-	0	-	-	3.1	2.6

HCM 2010 TWSC
7: Maple St & SR-14

Intersection												
Int Delay, s/veh	6.3											

Movement	EBL	EBT	EBR	WBL	WBT	WBR	NBL	NBT	NBR	SBL	SBT	SBR
Traffic Vol, veh/h	5	240	30	5	250	5	160	5	45	15	5	20
Future Vol, veh/h	5	240	30	5	250	5	160	5	45	15	5	20
Conflicting Peds, #/hr	4	0	2	2	0	4	1	0	1	1	0	1
Sign Control	Free	Free	Free	Free	Free	Free	Stop	Stop	Stop	Stop	Stop	Stop
RT Channelized	-	-	None	-	-	None	-	-	None	-	-	None
Storage Length	-	-	80	-	-	-	-	-	0	-	-	-
Veh in Median Storage, #	-	0	-	-	0	-	-	0	-	-	0	-
Grade, %	-	0	-	-	0	-	-	0	-	-	0	-
Peak Hour Factor	92	92	92	87	87	87	86	86	86	74	74	74
Heavy Vehicles, %	0	9	7	22	7	0	2	0	6	0	0	3
Mvmt Flow	5	261	33	6	287	6	186	6	52	20	7	27

Major/Minor	Major1			Major2			Minor1			Minor2		
Conflicting Flow All	294	0	0	262	0	0	593	579	266	579	576	295
Stage 1	-	-	-	-	-	-	273	273	-	303	303	-
Stage 2	-	-	-	-	-	-	320	306	-	276	273	-
Critical Hdwy	4.1	-	-	4.32	-	-	7.12	6.5	6.26	7.1	6.5	6.23
Critical Hdwy Stg 1	-	-	-	-	-	-	6.12	5.5	-	6.1	5.5	-
Critical Hdwy Stg 2	-	-	-	-	-	-	6.12	5.5	-	6.1	5.5	-
Follow-up Hdwy	2.2	-	-	2.398	-	-	3.518	4	3.354	3.5	4	3.327
Pot Cap-1 Maneuver	1279	-	-	1195	-	-	417	429	763	429	431	742
Stage 1	-	-	-	-	-	-	733	688	-	711	667	-
Stage 2	-	-	-	-	-	-	692	665	-	735	688	-
Platoon blocked, %	-	-	-	-	-	-	-	-	-	-	-	-
Mov Cap-1 Maneuver	1274	-	-	1190	-	-	392	423	759	390	425	738
Mov Cap-2 Maneuver	-	-	-	-	-	-	392	423	-	390	425	-
Stage 1	-	-	-	-	-	-	729	684	-	707	662	-
Stage 2	-	-	-	-	-	-	653	660	-	673	684	-

Approach	EB	WB	NB	SB
HCM Control Delay, s	0.1	0.2	19.9	12.8
HCM LOS			C	B

Minor Lane/Major Mvmt	NBLn1	NBLn2	EBL	EBT	EBR	WBL	WBT	WBR	SBLn1
Capacity (veh/h)	393	759	1274	-	-	1190	-	-	517
HCM Lane V/C Ratio	0.488	0.069	0.004	-	-	0.005	-	-	0.105
HCM Control Delay (s)	22.6	10.1	7.8	0	-	8	0	-	12.8
HCM Lane LOS	C	B	A	A	-	A	A	-	B
HCM 95th %tile Q(veh)	2.6	0.2	0	-	-	0	-	-	0.3

HCM 2010 TWSC
1: SR-14 & SR-141

Intersection

Int Delay, s/veh 7.1

Movement	EBL	EBT	WBT	WBR	SBL	SBR
Traffic Vol, veh/h	55	290	470	220	115	60
Future Vol, veh/h	55	290	470	220	115	60
Conflicting Peds, #/hr	0	0	0	0	0	0
Sign Control	Free	Free	Free	Free	Stop	Stop
RT Channelized	-	None	-	Free	-	None
Storage Length	-	-	-	-	0	-
Veh in Median Storage, #	-	0	0	-	0	-
Grade, %	-	0	0	-	0	-
Peak Hour Factor	86	86	87	87	88	88
Heavy Vehicles, %	4	11	5	2	6	7
Mvmt Flow	64	337	540	253	131	68

Major/Minor	Major1	Major2	Minor2
Conflicting Flow All	540	0	540
Stage 1	-	-	540
Stage 2	-	-	465
Critical Hdwy	4.14	-	6.27
Critical Hdwy Stg 1	-	-	5.46
Critical Hdwy Stg 2	-	-	5.46
Follow-up Hdwy	2.236	-	3.363
Pot Cap-1 Maneuver	1018	0	532
Stage 1	-	0	576
Stage 2	-	0	624
Platoon blocked, %	-	-	-
Mov Cap-1 Maneuver	1018	-	532
Mov Cap-2 Maneuver	-	-	243
Stage 1	-	-	576
Stage 2	-	-	576

Approach	EB	WB	SB
HCM Control Delay, s	1.4	0	38
HCM LOS			E

Minor Lane/Major Mvmt	EBL	EBT	WBT	SBLn1
Capacity (veh/h)	1018	-	-	299
HCM Lane V/C Ratio	0.063	-	-	0.665
HCM Control Delay (s)	8.8	0	-	38
HCM Lane LOS	A	A	-	E
HCM 95th %tile Q(veh)	0.2	-	-	4.4

HCM 2010 TWSC
 2: SR-14 & Dock Grade Rd

Intersection												
Int Delay, s/veh	1.1											

Movement	EBL	EBT	EBR	WBL	WBT	WBR	NBL	NBT	NBR	SBL	SBT	SBR
Traffic Vol, veh/h	60	340	5	10	675	350	15	5	5	0	0	0
Future Vol, veh/h	60	340	5	10	675	350	15	5	5	0	0	0
Conflicting Peds, #/hr	0	0	0	0	0	0	0	0	0	0	0	0
Sign Control	Free	Free	Free	Free	Free	Free	Stop	Stop	Stop	Stop	Stop	Stop
RT Channelized	-	-	None	-	-	None	-	-	None	-	-	None
Storage Length	125	-	-	125	-	325	-	-	-	-	-	-
Veh in Median Storage, #	-	0	-	-	0	-	-	0	-	-	0	-
Grade, %	-	0	-	-	0	-	-	0	-	-	0	-
Peak Hour Factor	86	86	86	91	91	91	67	67	67	92	92	92
Heavy Vehicles, %	1	14	8	0	21	5	0	0	0	2	2	2
Mvmt Flow	70	395	6	11	742	385	22	7	7	0	0	0

Major/Minor	Major1			Major2			Minor1		
Conflicting Flow All	742	0	0	401	0	0	1302	1302	398
Stage 1	-	-	-	-	-	-	538	538	-
Stage 2	-	-	-	-	-	-	764	764	-
Critical Hdwy	4.11	-	-	4.1	-	-	6.4	6.5	6.2
Critical Hdwy Stg 1	-	-	-	-	-	-	5.4	5.5	-
Critical Hdwy Stg 2	-	-	-	-	-	-	5.4	5.5	-
Follow-up Hdwy	2.209	-	-	2.2	-	-	3.5	4	3.3
Pot Cap-1 Maneuver	870	-	-	1169	-	-	179	162	656
Stage 1	-	-	-	-	-	-	589	526	-
Stage 2	-	-	-	-	-	-	463	416	-
Platoon blocked, %	-	-	-	-	-	-	-	-	-
Mov Cap-1 Maneuver	870	-	-	1169	-	-	163	0	656
Mov Cap-2 Maneuver	-	-	-	-	-	-	163	0	-
Stage 1	-	-	-	-	-	-	542	0	-
Stage 2	-	-	-	-	-	-	459	0	-

Approach	EB	WB	NB
HCM Control Delay, s	1.4	0.1	26.9
HCM LOS			D

Minor Lane/Major Mvmt	NBLn1	EBL	EBT	EBR	WBL	WBT	WBR
Capacity (veh/h)	201	870	-	-	1169	-	-
HCM Lane V/C Ratio	0.186	0.08	-	-	0.009	-	-
HCM Control Delay (s)	26.9	9.5	-	-	8.1	-	-
HCM Lane LOS	D	A	-	-	A	-	-
HCM 95th %tile Q(veh)	0.7	0.3	-	-	0	-	-

HCM Signalized Intersection Capacity Analysis

3: Hood River Bridge & SR-14

	→	↘	↙	←	↖	↗
Movement	EBT	EBR	WBL	WBT	NBL	NBR
Lane Configurations	↑	↗	↘	↑	↘	↗
Traffic Volume (vph)	150	195	605	395	640	280
Future Volume (vph)	150	195	605	395	640	280
Ideal Flow (vphpl)	1900	1900	1900	1900	1900	1900
Total Lost time (s)	5.0	5.0	4.0	5.0	5.0	5.0
Lane Util. Factor	1.00	1.00	1.00	1.00	1.00	1.00
Frbp, ped/bikes	1.00	1.00	1.00	1.00	1.00	1.00
Flpb, ped/bikes	1.00	1.00	1.00	1.00	1.00	1.00
Frt	1.00	0.85	1.00	1.00	1.00	0.85
Flt Protected	1.00	1.00	0.95	1.00	0.95	1.00
Satd. Flow (prot)	1545	1509	1770	1792	1787	1553
Flt Permitted	1.00	1.00	0.95	1.00	0.95	1.00
Satd. Flow (perm)	1545	1509	1770	1792	1787	1553
Peak-hour factor, PHF	0.84	0.84	0.97	0.97	0.89	0.89
Adj. Flow (vph)	179	232	624	407	719	315
RTOR Reduction (vph)	0	28	0	0	0	77
Lane Group Flow (vph)	179	204	624	407	719	238
Confl. Peds. (#/hr)		1	1			1
Heavy Vehicles (%)	23%	7%	2%	6%	1%	4%
Turn Type	NA	pt+ov	Prot	NA	Prot	pt+ov
Protected Phases	2	2 8	1	6	8	8 1
Permitted Phases						
Actuated Green, G (s)	27.0	74.0	37.0	68.0	42.0	84.0
Effective Green, g (s)	27.0	74.0	37.0	68.0	42.0	84.0
Actuated g/C Ratio	0.22	0.62	0.31	0.57	0.35	0.70
Clearance Time (s)	5.0		4.0	5.0	5.0	
Vehicle Extension (s)	3.0		3.0	3.0	3.0	
Lane Grp Cap (vph)	347	930	545	1015	625	1087
v/s Ratio Prot	c0.12	0.14	c0.35	0.23	c0.40	0.15
v/s Ratio Perm						
v/c Ratio	0.52	0.22	1.14	0.40	1.15	0.22
Uniform Delay, d1	40.8	10.2	41.5	14.6	39.0	6.4
Progression Factor	1.00	1.00	1.00	1.00	1.00	1.00
Incremental Delay, d2	5.4	0.1	85.2	0.3	85.2	0.1
Delay (s)	46.2	10.3	126.7	14.8	124.2	6.5
Level of Service	D	B	F	B	F	A
Approach Delay (s)	25.9			82.5	88.3	
Approach LOS	C			F	F	
Intersection Summary						
HCM 2000 Control Delay			75.6		HCM 2000 Level of Service	E
HCM 2000 Volume to Capacity ratio			0.99			
Actuated Cycle Length (s)			120.0		Sum of lost time (s)	14.0
Intersection Capacity Utilization			102.3%		ICU Level of Service	G
Analysis Period (min)			15			

c Critical Lane Group

Queues

3: Hood River Bridge & SR-14



Lane Group	EBT	EBR	WBL	WBT	NBL	NBR
Lane Group Flow (vph)	179	232	624	407	719	315
v/c Ratio	0.52	0.24	1.14	0.40	1.15	0.27
Control Delay	46.9	7.6	123.6	16.1	121.5	2.0
Queue Delay	0.0	0.0	0.0	0.0	0.0	0.0
Total Delay	46.9	7.6	123.6	16.1	121.5	2.0
Queue Length 50th (ft)	122	49	~566	168	~655	13
Queue Length 95th (ft)	182	79	#792	241	#874	40
Internal Link Dist (ft)	1219			2070	738	
Turn Bay Length (ft)		250	125			125
Base Capacity (vph)	347	958	545	1015	625	1153
Starvation Cap Reductn	0	0	0	0	0	0
Spillback Cap Reductn	0	0	0	0	0	0
Storage Cap Reductn	0	0	0	0	0	0
Reduced v/c Ratio	0.52	0.24	1.14	0.40	1.15	0.27

Intersection Summary

- ~ Volume exceeds capacity, queue is theoretically infinite.
Queue shown is maximum after two cycles.
- # 95th percentile volume exceeds capacity, queue may be longer.
Queue shown is maximum after two cycles.

HCM 2010 TWSC
4: Walnut St & SR-14

Intersection												
Int Delay, s/veh	14.3											

Movement	EBL	EBT	EBR	WBL	WBT	WBR	NBL	NBT	NBR	SBL	SBT	SBR
Traffic Vol, veh/h	10	470	10	15	895	25	35	5	40	5	5	20
Future Vol, veh/h	10	470	10	15	895	25	35	5	40	5	5	20
Conflicting Peds, #/hr	13	0	12	12	0	13	6	0	11	11	0	6
Sign Control	Free	Free	Free	Free	Free	Free	Stop	Stop	Stop	Stop	Stop	Stop
RT Channelized	-	-	None	-	-	None	-	-	None	-	-	None
Storage Length	-	-	-	-	-	-	-	-	-	-	-	-
Veh in Median Storage, #	-	0	-	-	0	-	-	0	-	-	0	-
Grade, %	-	0	-	-	0	-	-	0	-	-	0	-
Peak Hour Factor	81	81	81	92	92	92	65	65	65	73	73	73
Heavy Vehicles, %	0	8	8	5	4	4	2	0	0	0	0	3
Mvmt Flow	12	580	12	16	973	27	54	8	62	7	7	27

Major/Minor	Major1			Major2			Minor1			Minor2		
Conflicting Flow All	1011	0	0	604	0	0	1669	1666	610	1687	1658	1010
Stage 1	-	-	-	-	-	-	622	622	-	1030	1030	-
Stage 2	-	-	-	-	-	-	1047	1044	-	657	628	-
Critical Hdwy	4.1	-	-	4.15	-	-	7.12	6.5	6.2	7.1	6.5	6.23
Critical Hdwy Stg 1	-	-	-	-	-	-	6.12	5.5	-	6.1	5.5	-
Critical Hdwy Stg 2	-	-	-	-	-	-	6.12	5.5	-	6.1	5.5	-
Follow-up Hdwy	2.2	-	-	2.245	-	-	3.518	4	3.3	3.5	4	3.327
Pot Cap-1 Maneuver	694	-	-	959	-	-	76	98	498	75	99	290
Stage 1	-	-	-	-	-	-	474	482	-	284	313	-
Stage 2	-	-	-	-	-	-	276	309	-	457	479	-
Platoon blocked, %	-	-	-	-	-	-	-	-	-	-	-	-
Mov Cap-1 Maneuver	685	-	-	947	-	-	60	90	487	57	91	283
Mov Cap-2 Maneuver	-	-	-	-	-	-	60	90	-	57	91	-
Stage 1	-	-	-	-	-	-	457	465	-	274	298	-
Stage 2	-	-	-	-	-	-	231	294	-	378	462	-

Approach	EB	WB	NB	SB
HCM Control Delay, s	0.2	0.1	191.5	40.7
HCM LOS			F	E

Minor Lane/Major Mvmt	NBLn1	EBL	EBT	EBR	WBL	WBT	WBR	SBLn1
Capacity (veh/h)	111	685	-	-	947	-	-	141
HCM Lane V/C Ratio	1.109	0.018	-	-	0.017	-	-	0.291
HCM Control Delay (s)	191.5	10.4	0	-	8.9	0	-	40.7
HCM Lane LOS	F	B	A	-	A	A	-	E
HCM 95th %tile Q(veh)	7.6	0.1	-	-	0.1	-	-	1.1

HCM 2010 TWSC
5: Ash St & SR-14

Intersection												
Int Delay, s/veh	3.9											

Movement	EBL	EBT	EBR	WBL	WBT	WBR	NBL	NBT	NBR	SBL	SBT	SBR
Traffic Vol, veh/h	25	485	10	5	850	10	0	0	0	20	0	80
Future Vol, veh/h	25	485	10	5	850	10	0	0	0	20	0	80
Conflicting Peds, #/hr	3	0	9	9	0	3	8	0	8	8	0	8
Sign Control	Free	Free	Free	Free	Free	Free	Stop	Stop	Stop	Stop	Stop	Stop
RT Channelized	-	-	None	-	-	None	-	-	None	-	-	None
Storage Length	-	-	-	-	-	-	-	-	-	-	-	-
Veh in Median Storage, #	-	0	-	-	0	-	-	0	-	-	0	-
Grade, %	-	0	-	-	0	-	-	0	-	-	0	-
Peak Hour Factor	90	90	90	88	88	88	92	92	92	73	73	73
Heavy Vehicles, %	7	6	0	0	5	0	2	2	2	8	0	0
Mvmt Flow	28	539	11	6	966	11	0	0	0	27	0	110

Major/Minor	Major1			Major2			Minor2		
Conflicting Flow All	985	0	0	550	0	0	1591	1597	989
Stage 1	-	-	-	-	-	-	991	991	-
Stage 2	-	-	-	-	-	-	600	606	-
Critical Hdwy	4.17	-	-	4.1	-	-	6.48	6.5	6.2
Critical Hdwy Stg 1	-	-	-	-	-	-	5.48	5.5	-
Critical Hdwy Stg 2	-	-	-	-	-	-	5.48	5.5	-
Follow-up Hdwy	2.263	-	-	2.2	-	-	3.572	4	3.3
Pot Cap-1 Maneuver	682	-	-	1030	-	-	114	108	302
Stage 1	-	-	-	-	-	-	350	327	-
Stage 2	-	-	-	-	-	-	537	490	-
Platoon blocked, %	-	-	-	-	-	-	-	-	-
Mov Cap-1 Maneuver	676	-	-	1021	-	-	104	0	297
Mov Cap-2 Maneuver	-	-	-	-	-	-	104	0	-
Stage 1	-	-	-	-	-	-	343	0	-
Stage 2	-	-	-	-	-	-	501	0	-

Approach	EB	WB	SB
HCM Control Delay, s	0.5	0	46.3
HCM LOS			E

Minor Lane/Major Mvmt	EBL	EBT	EBR	WBL	WBT	WBR	SBLn1
Capacity (veh/h)	676	-	-	1021	-	-	217
HCM Lane V/C Ratio	0.041	-	-	0.006	-	-	0.631
HCM Control Delay (s)	10.6	0	-	8.5	0	-	46.3
HCM Lane LOS	B	A	-	A	A	-	E
HCM 95th %tile Q(veh)	0.1	-	-	0	-	-	3.7

HCM 2010 TWSC

6: Oak St

Intersection

Int Delay, s/veh 298.1

Movement	EBL	EBT	EBR	WBL	WBT	WBR	NBL	NBT	NBR	SBL	SBT	SBR
Traffic Vol, veh/h	210	290	10	10	480	245	20	20	20	100	0	355
Future Vol, veh/h	210	290	10	10	480	245	20	20	20	100	0	355
Conflicting Peds, #/hr	6	0	7	7	0	6	2	0	1	1	0	2
Sign Control	Free	Free	Free	Free	Free	Free	Stop	Stop	Stop	Stop	Stop	Stop
RT Channelized	-	-	None	-	-	None	-	-	None	-	-	None
Storage Length	100	-	-	-	-	-	-	-	-	-	-	75
Veh in Median Storage, #	-	0	-	-	0	-	-	0	-	-	0	-
Grade, %	-	0	-	-	0	-	-	0	-	-	0	-
Peak Hour Factor	79	79	79	90	90	90	83	83	83	81	81	81
Heavy Vehicles, %	3	12	50	0	7	2	13	4	0	5	0	1
Mvmt Flow	266	367	13	11	533	272	24	24	24	123	0	438

Major/Minor	Major1			Major2			Minor1			Minor2		
Conflicting Flow All	808	0	0	382	0	0	1601	1737	382	1625	1607	678
Stage 1	-	-	-	-	-	-	907	907	-	694	694	-
Stage 2	-	-	-	-	-	-	694	830	-	931	913	-
Critical Hdwy	4.13	-	-	4.1	-	-	7.23	6.54	6.2	7.15	6.5	6.21
Critical Hdwy Stg 1	-	-	-	-	-	-	6.23	5.54	-	6.15	5.5	-
Critical Hdwy Stg 2	-	-	-	-	-	-	6.23	5.54	-	6.15	5.5	-
Follow-up Hdwy	2.227	-	-	2.2	-	-	3.617	4.036	3.3	3.545	4	3.309
Pot Cap-1 Maneuver	813	-	-	1188	-	-	80	86	670	~ 81	106	454
Stage 1	-	-	-	-	-	-	316	352	-	428	447	-
Stage 2	-	-	-	-	-	-	416	382	-	316	355	-
Platoon blocked, %		-	-		-	-						
Mov Cap-1 Maneuver	808	-	-	1180	-	-	~ 2	56	664	~ 39	70	450
Mov Cap-2 Maneuver	-	-	-	-	-	-	~ 2	56	-	~ 39	70	-
Stage 1	-	-	-	-	-	-	212	236	-	287	438	-
Stage 2	-	-	-	-	-	-	~ 11	374	-	182	238	-

Approach	EB	WB	NB	SB
HCM Control Delay, s	4.8	0.1	\$ 6162.1	\$ 313.9
HCM LOS			F	F

Minor Lane/Major Mvmt	NBLn1	EBL	EBT	EBR	WBL	WBT	WBR	SBLn1	SBLn2
Capacity (veh/h)	6	808	-	-	1180	-	-	39	450
HCM Lane V/C Ratio	12.048	0.329	-	-	0.009	-	-	3.166	0.974
HCM Control Delay (s)	\$ 6162.1	11.6	-	-	8.1	0	\$ 1191.9	66.6	
HCM Lane LOS	F	B	-	-	A	A	-	F	F
HCM 95th %tile Q(veh)	10.8	1.4	-	-	0	-	-	13.9	12.1

Notes

~: Volume exceeds capacity \$: Delay exceeds 300s +: Computation Not Defined *: All major volume in platoon

HCM 2010 TWSC
7: Maple St & SR-14

Intersection												
Int Delay, s/veh	100.8											
Movement	EBL	EBT	EBR	WBL	WBT	WBR	NBL	NBT	NBR	SBL	SBT	SBR
Traffic Vol, veh/h	10	345	60	10	385	10	320	10	90	20	20	25
Future Vol, veh/h	10	345	60	10	385	10	320	10	90	20	20	25
Conflicting Peds, #/hr	4	0	2	2	0	4	1	0	1	1	0	1
Sign Control	Free	Free	Free	Free	Free	Free	Stop	Stop	Stop	Stop	Stop	Stop
RT Channelized	-	-	None	-	-	None	-	-	None	-	-	None
Storage Length	-	-	80	-	-	-	-	-	0	-	-	-
Veh in Median Storage, #	-	0	-	-	0	-	-	0	-	-	0	-
Grade, %	-	0	-	-	0	-	-	0	-	-	0	-
Peak Hour Factor	92	92	92	87	87	87	86	86	86	74	74	74
Heavy Vehicles, %	0	9	7	22	7	0	2	0	6	0	0	3
Mvmt Flow	11	375	65	11	443	11	372	12	105	27	27	34
Major/Minor	Major1			Major2			Minor1			Minor2		
Conflicting Flow All	455	0	0	376	0	0	901	876	380	876	870	453
Stage 1	-	-	-	-	-	-	398	398	-	472	472	-
Stage 2	-	-	-	-	-	-	503	478	-	404	398	-
Critical Hdwy	4.1	-	-	4.32	-	-	7.12	6.5	6.26	7.1	6.5	6.23
Critical Hdwy Stg 1	-	-	-	-	-	-	6.12	5.5	-	6.1	5.5	-
Critical Hdwy Stg 2	-	-	-	-	-	-	6.12	5.5	-	6.1	5.5	-
Follow-up Hdwy	2.2	-	-	2.398	-	-	3.518	4	3.354	3.5	4	3.327
Pot Cap-1 Maneuver	1116	-	-	1081	-	-	~ 259	290	658	272	292	605
Stage 1	-	-	-	-	-	-	628	606	-	576	562	-
Stage 2	-	-	-	-	-	-	551	559	-	627	606	-
Platoon blocked, %	-	-	-	-	-	-	-	-	-	-	-	-
Mov Cap-1 Maneuver	1112	-	-	1077	-	-	~ 221	282	655	216	284	602
Mov Cap-2 Maneuver	-	-	-	-	-	-	~ 221	282	-	216	284	-
Stage 1	-	-	-	-	-	-	619	598	-	568	554	-
Stage 2	-	-	-	-	-	-	486	551	-	508	598	-
Approach	EB			WB			NB			SB		
HCM Control Delay, s	0.2			0.2			\$ 304			20.6		
HCM LOS							F			C		
Minor Lane/Major Mvmt	NBLn1	NBLn2	EBL	EBT	EBR	WBL	WBT	WBR	SBLn1			
Capacity (veh/h)	222	655	1112	-	-	1077	-	-	318			
HCM Lane V/C Ratio	1.728	0.16	0.01	-	-	0.011	-	-	0.276			
HCM Control Delay (s)	\$ 383.8	11.5	8.3	0	-	8.4	0	-	20.6			
HCM Lane LOS	F	B	A	A	-	A	A	-	C			
HCM 95th %tile Q(veh)	25.8	0.6	0	-	-	0	-	-	1.1			
Notes												
-: Volume exceeds capacity \$: Delay exceeds 300s +: Computation Not Defined *: All major volume in platoon												

Intersection

Int Delay, s/veh 7.1

Movement	EBL	EBT	WBT	WBR	SBL	SBR
Traffic Vol, veh/h	55	290	470	220	115	60
Future Vol, veh/h	55	290	470	220	115	60
Conflicting Peds, #/hr	0	0	0	0	0	0
Sign Control	Free	Free	Free	Free	Stop	Stop
RT Channelized	-	None	-	Free	-	None
Storage Length	-	-	-	-	0	-
Veh in Median Storage, #	-	0	0	-	0	-
Grade, %	-	0	0	-	0	-
Peak Hour Factor	86	86	87	87	88	88
Heavy Vehicles, %	4	11	5	2	6	7
Mvmt Flow	64	337	540	253	131	68

Major/Minor	Major1	Major2	Minor2
Conflicting Flow All	540	0	540
Stage 1	-	-	540
Stage 2	-	-	465
Critical Hdwy	4.14	-	6.27
Critical Hdwy Stg 1	-	-	5.46
Critical Hdwy Stg 2	-	-	5.46
Follow-up Hdwy	2.236	-	3.363
Pot Cap-1 Maneuver	1018	-	532
Stage 1	-	-	576
Stage 2	-	-	624
Platoon blocked, %	-	-	-
Mov Cap-1 Maneuver	1018	-	532
Mov Cap-2 Maneuver	-	-	-
Stage 1	-	-	576
Stage 2	-	-	576

Approach	EB	WB	SB
HCM Control Delay, s	1.4	0	38
HCM LOS			E

Minor Lane/Major Mvmt	EBL	EBT	WBT	SBLn1
Capacity (veh/h)	1018	-	-	299
HCM Lane V/C Ratio	0.063	-	-	0.665
HCM Control Delay (s)	8.8	0	-	38
HCM Lane LOS	A	A	-	E
HCM 95th %tile Q(veh)	0.2	-	-	4.4

Intersection

Int Delay, s/veh 1.1

Movement	EBL	EBT	EBR	WBL	WBT	WBR	NBL	NBT	NBR	SBL	SBT	SBR
Traffic Vol, veh/h	60	340	5	10	675	350	15	5	5	0	0	0
Future Vol, veh/h	60	340	5	10	675	350	15	5	5	0	0	0
Conflicting Peds, #/hr	0	0	0	0	0	0	0	0	0	0	0	0
Sign Control	Free	Free	Free	Free	Free	Free	Stop	Stop	Stop	Stop	Stop	Stop
RT Channelized	-	-	None	-	-	None	-	-	None	-	-	None
Storage Length	125	-	-	125	-	325	-	-	-	-	-	-
Veh in Median Storage, #	-	0	-	-	0	-	-	0	-	-	0	-
Grade, %	-	0	-	-	0	-	-	0	-	-	0	-
Peak Hour Factor	86	86	86	91	91	91	67	67	67	92	92	92
Heavy Vehicles, %	1	14	8	0	21	5	0	0	0	2	2	2
Mvmt Flow	70	395	6	11	742	385	22	7	7	0	0	0

Major/Minor	Major1			Major2			Minor1		
Conflicting Flow All	742	0	0	401	0	0	1302	1302	398
Stage 1	-	-	-	-	-	-	538	538	-
Stage 2	-	-	-	-	-	-	764	764	-
Critical Hdwy	4.11	-	-	4.1	-	-	6.4	6.5	6.2
Critical Hdwy Stg 1	-	-	-	-	-	-	5.4	5.5	-
Critical Hdwy Stg 2	-	-	-	-	-	-	5.4	5.5	-
Follow-up Hdwy	2.209	-	-	2.2	-	-	3.5	4	3.3
Pot Cap-1 Maneuver	870	-	-	1169	-	-	179	162	656
Stage 1	-	-	-	-	-	-	589	526	-
Stage 2	-	-	-	-	-	-	463	416	-
Platoon blocked, %	-	-	-	-	-	-	-	-	-
Mov Cap-1 Maneuver	870	-	-	1169	-	-	163	0	656
Mov Cap-2 Maneuver	-	-	-	-	-	-	163	0	-
Stage 1	-	-	-	-	-	-	542	0	-
Stage 2	-	-	-	-	-	-	459	0	-

Approach	EB	WB	NB
HCM Control Delay, s	1.4	0.1	26.9
HCM LOS			D

Minor Lane/Major Mvmt	NBLn1	EBL	EBT	EBR	WBL	WBT	WBR
Capacity (veh/h)	201	870	-	-	1169	-	-
HCM Lane V/C Ratio	0.186	0.08	-	-	0.009	-	-
HCM Control Delay (s)	26.9	9.5	-	-	8.1	-	-
HCM Lane LOS	D	A	-	-	A	-	-
HCM 95th %tile Q(veh)	0.7	0.3	-	-	0	-	-

HCM Signalized Intersection Capacity Analysis

3: Hood River Bridge & SR-14

	→	↘	↙	←	↖	↗
Movement	EBT	EBR	WBL	WBT	NBL	NBR
Lane Configurations	↑	↗	↘	↑	↘	↗
Traffic Volume (vph)	150	195	605	395	640	280
Future Volume (vph)	150	195	605	395	640	280
Ideal Flow (vphpl)	1900	1900	1900	1900	1900	1900
Total Lost time (s)	5.0	5.0	4.0	5.0	5.0	5.0
Lane Util. Factor	1.00	1.00	1.00	1.00	1.00	1.00
Frbp, ped/bikes	1.00	1.00	1.00	1.00	1.00	1.00
Flpb, ped/bikes	1.00	1.00	1.00	1.00	1.00	1.00
Frt	1.00	0.85	1.00	1.00	1.00	0.85
Flt Protected	1.00	1.00	0.95	1.00	0.95	1.00
Satd. Flow (prot)	1545	1509	1770	1792	1787	1553
Flt Permitted	1.00	1.00	0.95	1.00	0.95	1.00
Satd. Flow (perm)	1545	1509	1770	1792	1787	1553
Peak-hour factor, PHF	0.84	0.84	0.97	0.97	0.89	0.89
Adj. Flow (vph)	179	232	624	407	719	315
RTOR Reduction (vph)	0	28	0	0	0	77
Lane Group Flow (vph)	179	204	624	407	719	238
Confl. Peds. (#/hr)		1	1			1
Heavy Vehicles (%)	23%	7%	2%	6%	1%	4%
Turn Type	NA	pt+ov	Prot	NA	Prot	pt+ov
Protected Phases	2	2 8	1	6	8	8 1
Permitted Phases						
Actuated Green, G (s)	27.0	74.0	37.0	68.0	42.0	84.0
Effective Green, g (s)	27.0	74.0	37.0	68.0	42.0	84.0
Actuated g/C Ratio	0.22	0.62	0.31	0.57	0.35	0.70
Clearance Time (s)	5.0		4.0	5.0	5.0	
Vehicle Extension (s)	3.0		3.0	3.0	3.0	
Lane Grp Cap (vph)	347	930	545	1015	625	1087
v/s Ratio Prot	c0.12	0.14	c0.35	0.23	c0.40	0.15
v/s Ratio Perm						
v/c Ratio	0.52	0.22	1.14	0.40	1.15	0.22
Uniform Delay, d1	40.8	10.2	41.5	14.6	39.0	6.4
Progression Factor	1.00	1.00	1.00	1.00	1.00	1.00
Incremental Delay, d2	5.4	0.1	85.2	0.3	85.2	0.1
Delay (s)	46.2	10.3	126.7	14.8	124.2	6.5
Level of Service	D	B	F	B	F	A
Approach Delay (s)	25.9			82.5	88.3	
Approach LOS	C			F	F	
Intersection Summary						
HCM 2000 Control Delay			75.6		HCM 2000 Level of Service	E
HCM 2000 Volume to Capacity ratio			0.99			
Actuated Cycle Length (s)			120.0		Sum of lost time (s)	14.0
Intersection Capacity Utilization			102.3%		ICU Level of Service	G
Analysis Period (min)			15			

c Critical Lane Group

Queues

3: Hood River Bridge & SR-14

	→	↘	↙	←	↖	↗
Lane Group	EBT	EBR	WBL	WBT	NBL	NBR
Lane Group Flow (vph)	179	232	624	407	719	315
v/c Ratio	0.52	0.24	1.14	0.40	1.15	0.27
Control Delay	46.9	7.6	123.6	16.1	121.5	2.0
Queue Delay	0.0	0.0	0.0	0.0	0.0	0.0
Total Delay	46.9	7.6	123.6	16.1	121.5	2.0
Queue Length 50th (ft)	122	49	~566	168	~655	13
Queue Length 95th (ft)	182	79	#792	241	#874	40
Internal Link Dist (ft)	1219			2070	431	
Turn Bay Length (ft)		250	125			125
Base Capacity (vph)	347	958	545	1015	625	1153
Starvation Cap Reductn	0	0	0	0	0	0
Spillback Cap Reductn	0	0	0	0	0	0
Storage Cap Reductn	0	0	0	0	0	0
Reduced v/c Ratio	0.52	0.24	1.14	0.40	1.15	0.27

Intersection Summary

- ~ Volume exceeds capacity, queue is theoretically infinite.
Queue shown is maximum after two cycles.
- # 95th percentile volume exceeds capacity, queue may be longer.
Queue shown is maximum after two cycles.

Intersection												
Int Delay, s/veh	14.3											
Movement	EBL	EBT	EBR	WBL	WBT	WBR	NBL	NBT	NBR	SBL	SBT	SBR
Traffic Vol, veh/h	10	470	10	15	895	25	35	5	40	5	5	20
Future Vol, veh/h	10	470	10	15	895	25	35	5	40	5	5	20
Conflicting Peds, #/hr	13	0	12	12	0	13	6	0	11	11	0	6
Sign Control	Free	Free	Free	Free	Free	Free	Stop	Stop	Stop	Stop	Stop	Stop
RT Channelized	-	-	None	-	-	None	-	-	None	-	-	None
Storage Length	-	-	-	-	-	-	-	-	-	-	-	-
Veh in Median Storage, #	-	0	-	-	0	-	-	0	-	-	0	-
Grade, %	-	0	-	-	0	-	-	0	-	-	0	-
Peak Hour Factor	81	81	81	92	92	92	65	65	65	73	73	73
Heavy Vehicles, %	0	8	8	5	4	4	2	0	0	0	0	3
Mvmt Flow	12	580	12	16	973	27	54	8	62	7	7	27
Major/Minor	Major1			Major2			Minor1			Minor2		
Conflicting Flow All	1011	0	0	604	0	0	1669	1666	610	1687	1658	1010
Stage 1	-	-	-	-	-	-	622	622	-	1030	1030	-
Stage 2	-	-	-	-	-	-	1047	1044	-	657	628	-
Critical Hdwy	4.1	-	-	4.15	-	-	7.12	6.5	6.2	7.1	6.5	6.23
Critical Hdwy Stg 1	-	-	-	-	-	-	6.12	5.5	-	6.1	5.5	-
Critical Hdwy Stg 2	-	-	-	-	-	-	6.12	5.5	-	6.1	5.5	-
Follow-up Hdwy	2.2	-	-	2.245	-	-	3.518	4	3.3	3.5	4	3.327
Pot Cap-1 Maneuver	694	-	-	959	-	-	76	98	498	75	99	290
Stage 1	-	-	-	-	-	-	474	482	-	284	313	-
Stage 2	-	-	-	-	-	-	276	309	-	457	479	-
Platoon blocked, %	-	-	-	-	-	-	-	-	-	-	-	-
Mov Cap-1 Maneuver	685	-	-	947	-	-	60	90	487	57	91	283
Mov Cap-2 Maneuver	-	-	-	-	-	-	60	90	-	57	91	-
Stage 1	-	-	-	-	-	-	457	465	-	274	298	-
Stage 2	-	-	-	-	-	-	231	294	-	378	462	-
Approach	EB			WB			NB			SB		
HCM Control Delay, s	0.2			0.1			191.5			40.7		
HCM LOS	F			F			F			E		
Minor Lane/Major Mvmt	NBLn1	EBL	EBT	EBR	WBL	WBT	WBR	SBLn1				
Capacity (veh/h)	111	685	-	-	947	-	-	141				
HCM Lane V/C Ratio	1.109	0.018	-	-	0.017	-	-	0.291				
HCM Control Delay (s)	191.5	10.4	0	-	8.9	0	-	40.7				
HCM Lane LOS	F	B	A	-	A	A	-	E				
HCM 95th %tile Q(veh)	7.6	0.1	-	-	0.1	-	-	1.1				

Intersection

Int Delay, s/veh 3.9

Movement	EBL	EBT	EBR	WBL	WBT	WBR	NBL	NBT	NBR	SBL	SBT	SBR
Traffic Vol, veh/h	25	485	10	5	850	10	0	0	0	20	0	80
Future Vol, veh/h	25	485	10	5	850	10	0	0	0	20	0	80
Conflicting Peds, #/hr	3	0	9	9	0	3	8	0	8	8	0	8
Sign Control	Free	Free	Free	Free	Free	Free	Stop	Stop	Stop	Stop	Stop	Stop
RT Channelized	-	-	None	-	-	None	-	-	None	-	-	None
Storage Length	-	-	-	-	-	-	-	-	-	-	-	-
Veh in Median Storage, #	-	0	-	-	0	-	-	0	-	-	0	-
Grade, %	-	0	-	-	0	-	-	0	-	-	0	-
Peak Hour Factor	90	90	90	88	88	88	92	92	92	73	73	73
Heavy Vehicles, %	7	6	0	0	5	0	2	2	2	8	0	0
Mvmt Flow	28	539	11	6	966	11	0	0	0	27	0	110

Major/Minor	Major1	Major2	Minor2						
Conflicting Flow All	985	0	0	550	0	0	1591	1597	989
Stage 1	-	-	-	-	-	-	991	991	-
Stage 2	-	-	-	-	-	-	600	606	-
Critical Hdwy	4.17	-	-	4.1	-	-	6.48	6.5	6.2
Critical Hdwy Stg 1	-	-	-	-	-	-	5.48	5.5	-
Critical Hdwy Stg 2	-	-	-	-	-	-	5.48	5.5	-
Follow-up Hdwy	2.263	-	-	2.2	-	-	3.572	4	3.3
Pot Cap-1 Maneuver	682	-	-	1030	-	-	114	108	302
Stage 1	-	-	-	-	-	-	350	327	-
Stage 2	-	-	-	-	-	-	537	490	-
Platoon blocked, %	-	-	-	-	-	-	-	-	-
Mov Cap-1 Maneuver	676	-	-	1021	-	-	104	0	297
Mov Cap-2 Maneuver	-	-	-	-	-	-	104	0	-
Stage 1	-	-	-	-	-	-	343	0	-
Stage 2	-	-	-	-	-	-	501	0	-

Approach	EB	WB	SB
HCM Control Delay, s	0.5	0	46.3
HCM LOS			E

Minor Lane/Major Mvmt	EBL	EBT	EBR	WBL	WBT	WBR	SBLn1
Capacity (veh/h)	676	-	-	1021	-	-	217
HCM Lane V/C Ratio	0.041	-	-	0.006	-	-	0.631
HCM Control Delay (s)	10.6	0	-	8.5	0	-	46.3
HCM Lane LOS	B	A	-	A	A	-	E
HCM 95th %tile Q(veh)	0.1	-	-	0	-	-	3.7

Intersection

Int Delay, s/veh 298.1

Movement	EBL	EBT	EBR	WBL	WBT	WBR	NBL	NBT	NBR	SBL	SBT	SBR
Traffic Vol, veh/h	210	290	10	10	480	245	20	20	20	100	0	355
Future Vol, veh/h	210	290	10	10	480	245	20	20	20	100	0	355
Conflicting Peds, #/hr	6	0	7	7	0	6	2	0	1	1	0	2
Sign Control	Free	Free	Free	Free	Free	Free	Stop	Stop	Stop	Stop	Stop	Stop
RT Channelized	-	-	None	-	-	None	-	-	None	-	-	None
Storage Length	100	-	-	-	-	-	-	-	-	-	-	75
Veh in Median Storage, #	-	0	-	-	0	-	-	0	-	-	0	-
Grade, %	-	0	-	-	0	-	-	0	-	-	0	-
Peak Hour Factor	79	79	79	90	90	90	83	83	83	81	81	81
Heavy Vehicles, %	3	12	50	0	7	2	13	4	0	5	0	1
Mvmt Flow	266	367	13	11	533	272	24	24	24	123	0	438

Major/Minor	Major1	Major2	Minor1	Minor2								
Conflicting Flow All	808	0	0	382	0	0	1601	1737	382	1625	1607	678
Stage 1	-	-	-	-	-	-	907	907	-	694	694	-
Stage 2	-	-	-	-	-	-	694	830	-	931	913	-
Critical Hdwy	4.13	-	-	4.1	-	-	7.23	6.54	6.2	7.15	6.5	6.21
Critical Hdwy Stg 1	-	-	-	-	-	-	6.23	5.54	-	6.15	5.5	-
Critical Hdwy Stg 2	-	-	-	-	-	-	6.23	5.54	-	6.15	5.5	-
Follow-up Hdwy	2.227	-	-	2.2	-	-	3.617	4.036	3.3	3.545	4	3.309
Pot Cap-1 Maneuver	813	-	-	1188	-	-	80	86	670	~ 81	106	454
Stage 1	-	-	-	-	-	-	316	352	-	428	447	-
Stage 2	-	-	-	-	-	-	416	382	-	316	355	-
Platoon blocked, %	-	-	-	-	-	-	-	-	-	-	-	-
Mov Cap-1 Maneuver	808	-	-	1180	-	-	~ 2	56	664	~ 39	70	450
Mov Cap-2 Maneuver	-	-	-	-	-	-	~ 2	56	-	~ 39	70	-
Stage 1	-	-	-	-	-	-	212	236	-	287	438	-
Stage 2	-	-	-	-	-	-	~ 11	374	-	182	238	-

Approach	EB	WB	NB	SB
HCM Control Delay, s	4.8	0.1	\$ 6162.1	\$ 313.9
HCM LOS			F	F

Minor Lane/Major Mvmt	NBLn1	EBL	EBT	EBR	WBL	WBT	WBR	SBLn1	SBLn2
Capacity (veh/h)	6	808	-	-	1180	-	-	39	450
HCM Lane V/C Ratio	12.048	0.329	-	-	0.009	-	-	3.166	0.974
HCM Control Delay (s)	\$ 6162.1	11.6	-	-	8.1	0	\$ 1191.9	66.6	
HCM Lane LOS	F	B	-	-	A	A	-	F	F
HCM 95th %tile Q(veh)	10.8	1.4	-	-	0	-	-	13.9	12.1

Notes

~: Volume exceeds capacity \$: Delay exceeds 300s +: Computation Not Defined *: All major volume in platoon

Intersection

Int Delay, s/veh 58.3

Movement	EBL	EBT	EBR	WBL	WBT	WBR	NBL	NBT	NBR	SBL	SBT	SBR
Traffic Vol, veh/h	10	365	40	5	480	10	225	10	65	20	20	25
Future Vol, veh/h	10	365	40	5	480	10	225	10	65	20	20	25
Conflicting Peds, #/hr	4	0	2	2	0	4	1	0	1	1	0	1
Sign Control	Free	Free	Free	Free	Free	Free	Stop	Stop	Stop	Stop	Stop	Stop
RT Channelized	-	-	None	-	-	None	-	-	None	-	-	None
Storage Length	-	-	80	-	-	-	-	-	0	-	-	-
Veh in Median Storage, #	-	0	-	-	0	-	-	0	-	-	0	-
Grade, %	-	0	-	-	0	-	-	0	-	-	0	-
Peak Hour Factor	92	92	92	87	87	87	86	86	86	74	74	74
Heavy Vehicles, %	0	9	7	22	7	0	2	0	6	0	0	3
Mvmt Flow	11	397	43	6	552	11	262	12	76	27	27	34

Major/Minor	Major1			Major2			Minor1			Minor2		
Conflicting Flow All	564	0	0	398	0	0	1019	995	402	995	989	562
Stage 1	-	-	-	-	-	-	419	419	-	570	570	-
Stage 2	-	-	-	-	-	-	600	576	-	425	419	-
Critical Hdwy	4.1	-	-	4.32	-	-	7.12	6.5	6.26	7.1	6.5	6.23
Critical Hdwy Stg 1	-	-	-	-	-	-	6.12	5.5	-	6.1	5.5	-
Critical Hdwy Stg 2	-	-	-	-	-	-	6.12	5.5	-	6.1	5.5	-
Follow-up Hdwy	2.2	-	-	2.398	-	-	3.518	4	3.354	3.5	4	3.327
Pot Cap-1 Maneuver	1018	-	-	1060	-	-	~ 215	247	640	226	249	525
Stage 1	-	-	-	-	-	-	612	593	-	510	509	-
Stage 2	-	-	-	-	-	-	488	505	-	611	593	-
Platoon blocked, %	-	-	-	-	-	-	-	-	-	-	-	-
Mov Cap-1 Maneuver	1014	-	-	1056	-	-	~ 180	241	637	188	243	523
Mov Cap-2 Maneuver	-	-	-	-	-	-	~ 180	241	-	188	243	-
Stage 1	-	-	-	-	-	-	603	584	-	502	504	-
Stage 2	-	-	-	-	-	-	427	500	-	518	584	-

Approach	EB	WB	NB	SB
HCM Control Delay, s	0.2	0.1	236.8	24.1
HCM LOS			F	C

Minor Lane/Major Mvmt	NBLn1	NBLn2	EBL	EBT	EBR	WBL	WBT	WBR	SBLn1
Capacity (veh/h)	182	637	1014	-	-	1056	-	-	275
HCM Lane V/C Ratio	1.501	0.119	0.011	-	-	0.005	-	-	0.319
HCM Control Delay (s)	299.1	11.4	8.6	0	-	8.4	0	-	24.1
HCM Lane LOS	F	B	A	A	-	A	A	-	C
HCM 95th %tile Q(veh)	17.3	0.4	0	-	-	0	-	-	1.3

Notes

-: Volume exceeds capacity \$: Delay exceeds 300s +: Computation Not Defined *: All major volume in platoon

Intersection

Int Delay, s/veh 2.6

Movement	EBT	EBR	WBL	WBT	NBL	NBR
Traffic Vol, veh/h	430	20	5	400	95	25
Future Vol, veh/h	430	20	5	400	95	25
Conflicting Peds, #/hr	0	0	0	0	0	0
Sign Control	Free	Free	Free	Free	Stop	Stop
RT Channelized	-	None	-	None	-	None
Storage Length	-	-	200	-	0	0
Veh in Median Storage, #	0	-	-	0	0	-
Grade, %	0	-	-	0	0	-
Peak Hour Factor	92	92	92	92	92	92
Heavy Vehicles, %	9	7	22	7	2	6
Mvmt Flow	467	22	5	435	103	27

Major/Minor	Major1	Major2	Minor1
Conflicting Flow All	0	0	489
Stage 1	-	-	-
Stage 2	-	-	-
Critical Hdwy	-	-	4.32
Critical Hdwy Stg 1	-	-	-
Critical Hdwy Stg 2	-	-	-
Follow-up Hdwy	-	-	2.398
Pot Cap-1 Maneuver	-	-	978
Stage 1	-	-	-
Stage 2	-	-	-
Platoon blocked, %	-	-	-
Mov Cap-1 Maneuver	-	-	978
Mov Cap-2 Maneuver	-	-	-
Stage 1	-	-	-
Stage 2	-	-	-

Approach	EB	WB	NB
HCM Control Delay, s	0	0.1	20.9
HCM LOS			C

Minor Lane/Major Mvmt	NBLn1	NBLn2	EBT	EBR	WBL	WBT
Capacity (veh/h)	297	579	-	-	978	-
HCM Lane V/C Ratio	0.348	0.047	-	-	0.006	-
HCM Control Delay (s)	23.4	11.5	-	-	8.7	-
HCM Lane LOS	C	B	-	-	A	-
HCM 95th %tile Q(veh)	1.5	0.1	-	-	0	-

HCM 2010 TWSC
1: SR-14 & SR-141

Intersection

Int Delay, s/veh 7.1

Movement	EBL	EBT	WBT	WBR	SBL	SBR
Traffic Vol, veh/h	55	290	470	220	115	60
Future Vol, veh/h	55	290	470	220	115	60
Conflicting Peds, #/hr	0	0	0	0	0	0
Sign Control	Free	Free	Free	Free	Stop	Stop
RT Channelized	-	None	-	Free	-	None
Storage Length	-	-	-	-	0	-
Veh in Median Storage, #	-	0	0	-	0	-
Grade, %	-	0	0	-	0	-
Peak Hour Factor	86	86	87	87	88	88
Heavy Vehicles, %	4	11	5	2	6	7
Mvmt Flow	64	337	540	253	131	68

Major/Minor	Major1	Major2	Minor2
Conflicting Flow All	540	0	540
Stage 1	-	-	540
Stage 2	-	-	465
Critical Hdwy	4.14	-	6.27
Critical Hdwy Stg 1	-	-	5.46
Critical Hdwy Stg 2	-	-	5.46
Follow-up Hdwy	2.236	-	3.363
Pot Cap-1 Maneuver	1018	-	532
Stage 1	-	-	576
Stage 2	-	-	624
Platoon blocked, %	-	-	-
Mov Cap-1 Maneuver	1018	-	532
Mov Cap-2 Maneuver	-	-	-
Stage 1	-	-	576
Stage 2	-	-	576

Approach	EB	WB	SB
HCM Control Delay, s	1.4	0	38
HCM LOS			E

Minor Lane/Major Mvmt	EBL	EBT	WBT	SBLn1
Capacity (veh/h)	1018	-	-	299
HCM Lane V/C Ratio	0.063	-	-	0.665
HCM Control Delay (s)	8.8	0	-	38
HCM Lane LOS	A	A	-	E
HCM 95th %tile Q(veh)	0.2	-	-	4.4

HCM 2010 TWSC
 2: SR-14 & Dock Grade Rd

Intersection												
Int Delay, s/veh	1.1											

Movement	EBL	EBT	EBR	WBL	WBT	WBR	NBL	NBT	NBR	SBL	SBT	SBR
Traffic Vol, veh/h	60	340	5	10	675	350	15	5	5	0	0	0
Future Vol, veh/h	60	340	5	10	675	350	15	5	5	0	0	0
Conflicting Peds, #/hr	0	0	0	0	0	0	0	0	0	0	0	0
Sign Control	Free	Free	Free	Free	Free	Free	Stop	Stop	Stop	Stop	Stop	Stop
RT Channelized	-	-	None	-	-	None	-	-	None	-	-	None
Storage Length	125	-	-	125	-	325	-	-	-	-	-	-
Veh in Median Storage, #	-	0	-	-	0	-	-	0	-	-	0	-
Grade, %	-	0	-	-	0	-	-	0	-	-	0	-
Peak Hour Factor	86	86	86	91	91	91	67	67	67	92	92	92
Heavy Vehicles, %	1	14	8	0	21	5	0	0	0	2	2	2
Mvmt Flow	70	395	6	11	742	385	22	7	7	0	0	0

Major/Minor	Major1			Major2			Minor1		
Conflicting Flow All	742	0	0	401	0	0	1302	1302	398
Stage 1	-	-	-	-	-	-	538	538	-
Stage 2	-	-	-	-	-	-	764	764	-
Critical Hdwy	4.11	-	-	4.1	-	-	6.4	6.5	6.2
Critical Hdwy Stg 1	-	-	-	-	-	-	5.4	5.5	-
Critical Hdwy Stg 2	-	-	-	-	-	-	5.4	5.5	-
Follow-up Hdwy	2.209	-	-	2.2	-	-	3.5	4	3.3
Pot Cap-1 Maneuver	870	-	-	1169	-	-	179	162	656
Stage 1	-	-	-	-	-	-	589	526	-
Stage 2	-	-	-	-	-	-	463	416	-
Platoon blocked, %	-	-	-	-	-	-	-	-	-
Mov Cap-1 Maneuver	870	-	-	1169	-	-	163	0	656
Mov Cap-2 Maneuver	-	-	-	-	-	-	163	0	-
Stage 1	-	-	-	-	-	-	542	0	-
Stage 2	-	-	-	-	-	-	459	0	-

Approach	EB	WB	NB
HCM Control Delay, s	1.4	0.1	26.9
HCM LOS			D

Minor Lane/Major Mvmt	NBLn1	EBL	EBT	EBR	WBL	WBT	WBR
Capacity (veh/h)	201	870	-	-	1169	-	-
HCM Lane V/C Ratio	0.186	0.08	-	-	0.009	-	-
HCM Control Delay (s)	26.9	9.5	-	-	8.1	-	-
HCM Lane LOS	D	A	-	-	A	-	-
HCM 95th %tile Q(veh)	0.7	0.3	-	-	0	-	-

HCM Signalized Intersection Capacity Analysis

3: Hood River Bridge & SR-14

	→	↘	↙	←	↖	↗
Movement	EBT	EBR	WBL	WBT	NBL	NBR
Lane Configurations	↑	↗	↘	↑	↘	↗
Traffic Volume (vph)	150	195	605	395	640	280
Future Volume (vph)	150	195	605	395	640	280
Ideal Flow (vphpl)	1900	1900	1900	1900	1900	1900
Total Lost time (s)	5.0	5.0	4.0	5.0	5.0	5.0
Lane Util. Factor	1.00	1.00	1.00	1.00	1.00	1.00
Frbp, ped/bikes	1.00	1.00	1.00	1.00	1.00	1.00
Flpb, ped/bikes	1.00	1.00	1.00	1.00	1.00	1.00
Frt	1.00	0.85	1.00	1.00	1.00	0.85
Flt Protected	1.00	1.00	0.95	1.00	0.95	1.00
Satd. Flow (prot)	1545	1509	1770	1792	1787	1553
Flt Permitted	1.00	1.00	0.95	1.00	0.95	1.00
Satd. Flow (perm)	1545	1509	1770	1792	1787	1553
Peak-hour factor, PHF	0.84	0.84	0.97	0.97	0.89	0.89
Adj. Flow (vph)	179	232	624	407	719	315
RTOR Reduction (vph)	0	28	0	0	0	77
Lane Group Flow (vph)	179	204	624	407	719	238
Confl. Peds. (#/hr)		1	1			1
Heavy Vehicles (%)	23%	7%	2%	6%	1%	4%
Turn Type	NA	pt+ov	Prot	NA	Prot	pt+ov
Protected Phases	2	2 8	1	6	8	8 1
Permitted Phases						
Actuated Green, G (s)	27.0	74.0	37.0	68.0	42.0	84.0
Effective Green, g (s)	27.0	74.0	37.0	68.0	42.0	84.0
Actuated g/C Ratio	0.22	0.62	0.31	0.57	0.35	0.70
Clearance Time (s)	5.0		4.0	5.0	5.0	
Vehicle Extension (s)	3.0		3.0	3.0	3.0	
Lane Grp Cap (vph)	347	930	545	1015	625	1087
v/s Ratio Prot	c0.12	0.14	c0.35	0.23	c0.40	0.15
v/s Ratio Perm						
v/c Ratio	0.52	0.22	1.14	0.40	1.15	0.22
Uniform Delay, d1	40.8	10.2	41.5	14.6	39.0	6.4
Progression Factor	1.00	1.00	1.00	1.00	1.00	1.00
Incremental Delay, d2	5.4	0.1	85.2	0.3	85.2	0.1
Delay (s)	46.2	10.3	126.7	14.8	124.2	6.5
Level of Service	D	B	F	B	F	A
Approach Delay (s)	25.9			82.5	88.3	
Approach LOS	C			F	F	
Intersection Summary						
HCM 2000 Control Delay			75.6		HCM 2000 Level of Service	E
HCM 2000 Volume to Capacity ratio			0.99			
Actuated Cycle Length (s)			120.0		Sum of lost time (s)	14.0
Intersection Capacity Utilization			102.3%		ICU Level of Service	G
Analysis Period (min)			15			

c Critical Lane Group

Queues

3: Hood River Bridge & SR-14

	→	↘	↙	←	↖	↗
Lane Group	EBT	EBR	WBL	WBT	NBL	NBR
Lane Group Flow (vph)	179	232	624	407	719	315
v/c Ratio	0.52	0.24	1.14	0.40	1.15	0.27
Control Delay	46.9	7.6	123.6	16.1	121.5	2.0
Queue Delay	0.0	0.0	0.0	0.0	0.0	0.0
Total Delay	46.9	7.6	123.6	16.1	121.5	2.0
Queue Length 50th (ft)	122	49	~566	168	~655	13
Queue Length 95th (ft)	182	79	#792	241	#874	40
Internal Link Dist (ft)	1219			2070	431	
Turn Bay Length (ft)		250	125			125
Base Capacity (vph)	347	958	545	1015	625	1153
Starvation Cap Reductn	0	0	0	0	0	0
Spillback Cap Reductn	0	0	0	0	0	0
Storage Cap Reductn	0	0	0	0	0	0
Reduced v/c Ratio	0.52	0.24	1.14	0.40	1.15	0.27

Intersection Summary

- ~ Volume exceeds capacity, queue is theoretically infinite.
Queue shown is maximum after two cycles.
- # 95th percentile volume exceeds capacity, queue may be longer.
Queue shown is maximum after two cycles.

HCM 2010 TWSC
4: Walnut St & SR-14

Intersection												
Int Delay, s/veh	14.3											

Movement	EBL	EBT	EBR	WBL	WBT	WBR	NBL	NBT	NBR	SBL	SBT	SBR
Traffic Vol, veh/h	10	470	10	15	895	25	35	5	40	5	5	20
Future Vol, veh/h	10	470	10	15	895	25	35	5	40	5	5	20
Conflicting Peds, #/hr	13	0	12	12	0	13	6	0	11	11	0	6
Sign Control	Free	Free	Free	Free	Free	Free	Stop	Stop	Stop	Stop	Stop	Stop
RT Channelized	-	-	None	-	-	None	-	-	None	-	-	None
Storage Length	-	-	-	-	-	-	-	-	-	-	-	-
Veh in Median Storage, #	-	0	-	-	0	-	-	0	-	-	0	-
Grade, %	-	0	-	-	0	-	-	0	-	-	0	-
Peak Hour Factor	81	81	81	92	92	92	65	65	65	73	73	73
Heavy Vehicles, %	0	8	8	5	4	4	2	0	0	0	0	3
Mvmt Flow	12	580	12	16	973	27	54	8	62	7	7	27

Major/Minor	Major1			Major2			Minor1			Minor2		
Conflicting Flow All	1011	0	0	604	0	0	1669	1666	610	1687	1658	1010
Stage 1	-	-	-	-	-	-	622	622	-	1030	1030	-
Stage 2	-	-	-	-	-	-	1047	1044	-	657	628	-
Critical Hdwy	4.1	-	-	4.15	-	-	7.12	6.5	6.2	7.1	6.5	6.23
Critical Hdwy Stg 1	-	-	-	-	-	-	6.12	5.5	-	6.1	5.5	-
Critical Hdwy Stg 2	-	-	-	-	-	-	6.12	5.5	-	6.1	5.5	-
Follow-up Hdwy	2.2	-	-	2.245	-	-	3.518	4	3.3	3.5	4	3.327
Pot Cap-1 Maneuver	694	-	-	959	-	-	76	98	498	75	99	290
Stage 1	-	-	-	-	-	-	474	482	-	284	313	-
Stage 2	-	-	-	-	-	-	276	309	-	457	479	-
Platoon blocked, %	-	-	-	-	-	-	-	-	-	-	-	-
Mov Cap-1 Maneuver	685	-	-	947	-	-	60	90	487	57	91	283
Mov Cap-2 Maneuver	-	-	-	-	-	-	60	90	-	57	91	-
Stage 1	-	-	-	-	-	-	457	465	-	274	298	-
Stage 2	-	-	-	-	-	-	231	294	-	378	462	-

Approach	EB	WB	NB	SB
HCM Control Delay, s	0.2	0.1	191.5	40.7
HCM LOS			F	E

Minor Lane/Major Mvmt	NBLn1	EBL	EBT	EBR	WBL	WBT	WBR	SBLn1
Capacity (veh/h)	111	685	-	-	947	-	-	141
HCM Lane V/C Ratio	1.109	0.018	-	-	0.017	-	-	0.291
HCM Control Delay (s)	191.5	10.4	0	-	8.9	0	-	40.7
HCM Lane LOS	F	B	A	-	A	A	-	E
HCM 95th %tile Q(veh)	7.6	0.1	-	-	0.1	-	-	1.1

HCM 2010 TWSC
5: Ash St & SR-14

Intersection												
Int Delay, s/veh	3.9											

Movement	EBL	EBT	EBR	WBL	WBT	WBR	NBL	NBT	NBR	SBL	SBT	SBR
Traffic Vol, veh/h	25	485	10	5	850	10	0	0	0	20	0	80
Future Vol, veh/h	25	485	10	5	850	10	0	0	0	20	0	80
Conflicting Peds, #/hr	3	0	9	9	0	3	8	0	8	8	0	8
Sign Control	Free	Free	Free	Free	Free	Free	Stop	Stop	Stop	Stop	Stop	Stop
RT Channelized	-	-	None	-	-	None	-	-	None	-	-	None
Storage Length	-	-	-	-	-	-	-	-	-	-	-	-
Veh in Median Storage, #	-	0	-	-	0	-	-	0	-	-	0	-
Grade, %	-	0	-	-	0	-	-	0	-	-	0	-
Peak Hour Factor	90	90	90	88	88	88	92	92	92	73	73	73
Heavy Vehicles, %	7	6	0	0	5	0	2	2	2	8	0	0
Mvmt Flow	28	539	11	6	966	11	0	0	0	27	0	110

Major/Minor	Major1			Major2			Minor2		
Conflicting Flow All	985	0	0	550	0	0	1591	1597	989
Stage 1	-	-	-	-	-	-	991	991	-
Stage 2	-	-	-	-	-	-	600	606	-
Critical Hdwy	4.17	-	-	4.1	-	-	6.48	6.5	6.2
Critical Hdwy Stg 1	-	-	-	-	-	-	5.48	5.5	-
Critical Hdwy Stg 2	-	-	-	-	-	-	5.48	5.5	-
Follow-up Hdwy	2.263	-	-	2.2	-	-	3.572	4	3.3
Pot Cap-1 Maneuver	682	-	-	1030	-	-	114	108	302
Stage 1	-	-	-	-	-	-	350	327	-
Stage 2	-	-	-	-	-	-	537	490	-
Platoon blocked, %	-	-	-	-	-	-	-	-	-
Mov Cap-1 Maneuver	676	-	-	1021	-	-	104	0	297
Mov Cap-2 Maneuver	-	-	-	-	-	-	104	0	-
Stage 1	-	-	-	-	-	-	343	0	-
Stage 2	-	-	-	-	-	-	501	0	-

Approach	EB	WB	SB
HCM Control Delay, s	0.5	0	46.3
HCM LOS			E

Minor Lane/Major Mvmt	EBL	EBT	EBR	WBL	WBT	WBR	SBLn1
Capacity (veh/h)	676	-	-	1021	-	-	217
HCM Lane V/C Ratio	0.041	-	-	0.006	-	-	0.631
HCM Control Delay (s)	10.6	0	-	8.5	0	-	46.3
HCM Lane LOS	B	A	-	A	A	-	E
HCM 95th %tile Q(veh)	0.1	-	-	0	-	-	3.7

HCM 2010 TWSC
6: Oak St & SR-14

Intersection

Int Delay, s/veh 298.1

Movement	EBL	EBT	EBR	WBL	WBT	WBR	NBL	NBT	NBR	SBL	SBT	SBR
Traffic Vol, veh/h	210	290	10	10	480	245	20	20	20	100	0	355
Future Vol, veh/h	210	290	10	10	480	245	20	20	20	100	0	355
Conflicting Peds, #/hr	6	0	7	7	0	6	2	0	1	1	0	2
Sign Control	Free	Free	Free	Free	Free	Free	Stop	Stop	Stop	Stop	Stop	Stop
RT Channelized	-	-	None	-	-	None	-	-	None	-	-	None
Storage Length	100	-	-	-	-	-	-	-	-	-	-	75
Veh in Median Storage, #	-	0	-	-	0	-	-	0	-	-	0	-
Grade, %	-	0	-	-	0	-	-	0	-	-	0	-
Peak Hour Factor	79	79	79	90	90	90	83	83	83	81	81	81
Heavy Vehicles, %	3	12	50	0	7	2	13	4	0	5	0	1
Mvmt Flow	266	367	13	11	533	272	24	24	24	123	0	438

Major/Minor	Major1			Major2			Minor1			Minor2		
Conflicting Flow All	808	0	0	382	0	0	1601	1737	382	1625	1607	678
Stage 1	-	-	-	-	-	-	907	907	-	694	694	-
Stage 2	-	-	-	-	-	-	694	830	-	931	913	-
Critical Hdwy	4.13	-	-	4.1	-	-	7.23	6.54	6.2	7.15	6.5	6.21
Critical Hdwy Stg 1	-	-	-	-	-	-	6.23	5.54	-	6.15	5.5	-
Critical Hdwy Stg 2	-	-	-	-	-	-	6.23	5.54	-	6.15	5.5	-
Follow-up Hdwy	2.227	-	-	2.2	-	-	3.617	4.036	3.3	3.545	4	3.309
Pot Cap-1 Maneuver	813	-	-	1188	-	-	80	86	670	~ 81	106	454
Stage 1	-	-	-	-	-	-	316	352	-	428	447	-
Stage 2	-	-	-	-	-	-	416	382	-	316	355	-
Platoon blocked, %		-	-		-	-						
Mov Cap-1 Maneuver	808	-	-	1180	-	-	~ 2	56	664	~ 39	70	450
Mov Cap-2 Maneuver	-	-	-	-	-	-	~ 2	56	-	~ 39	70	-
Stage 1	-	-	-	-	-	-	212	236	-	287	438	-
Stage 2	-	-	-	-	-	-	~ 11	374	-	182	238	-

Approach	EB	WB	NB	SB
HCM Control Delay, s	4.8	0.1	\$ 6162.1	\$ 313.9
HCM LOS			F	F

Minor Lane/Major Mvmt	NBLn1	EBL	EBT	EBR	WBL	WBT	WBR	SBLn1	SBLn2
Capacity (veh/h)	6	808	-	-	1180	-	-	39	450
HCM Lane V/C Ratio	12.048	0.329	-	-	0.009	-	-	3.166	0.974
HCM Control Delay (s)	\$ 6162.1	11.6	-	-	8.1	0	\$ 1191.9	66.6	
HCM Lane LOS	F	B	-	-	A	A	-	F	F
HCM 95th %tile Q(veh)	10.8	1.4	-	-	0	-	-	13.9	12.1

Notes

~: Volume exceeds capacity \$: Delay exceeds 300s +: Computation Not Defined *: All major volume in platoon

HCM 2010 TWSC
7: Maple St & SR-14

Intersection												
Int Delay, s/veh	7.6											

Movement	EBL	EBT	EBR	WBL	WBT	WBR	NBL	NBT	NBR	SBL	SBT	SBR
Traffic Vol, veh/h	10	385	20	5	625	5	95	5	25	5	5	10
Future Vol, veh/h	10	385	20	5	625	5	95	5	25	5	5	10
Conflicting Peds, #/hr	4	0	2	2	0	4	1	0	1	1	0	1
Sign Control	Free	Free	Free	Free	Free	Free	Stop	Stop	Stop	Stop	Stop	Stop
RT Channelized	-	-	None	-	-	None	-	-	None	-	-	None
Storage Length	-	-	80	-	-	-	-	-	0	-	-	-
Veh in Median Storage, #	-	0	-	-	0	-	-	0	-	-	0	-
Grade, %	-	0	-	-	0	-	-	0	-	-	0	-
Peak Hour Factor	92	92	92	87	87	87	86	86	86	74	74	74
Heavy Vehicles, %	0	9	7	22	7	0	2	0	6	0	0	3
Mvmt Flow	11	418	22	6	718	6	110	6	29	7	7	14

Major/Minor	Major1			Major2			Minor1			Minor2		
Conflicting Flow All	725	0	0	419	0	0	1185	1178	423	1178	1175	726
Stage 1	-	-	-	-	-	-	441	441	-	734	734	-
Stage 2	-	-	-	-	-	-	744	737	-	444	441	-
Critical Hdwy	4.1	-	-	4.32	-	-	7.12	6.5	6.26	7.1	6.5	6.23
Critical Hdwy Stg 1	-	-	-	-	-	-	6.12	5.5	-	6.1	5.5	-
Critical Hdwy Stg 2	-	-	-	-	-	-	6.12	5.5	-	6.1	5.5	-
Follow-up Hdwy	2.2	-	-	2.398	-	-	3.518	4	3.354	3.5	4	3.327
Pot Cap-1 Maneuver	887	-	-	1041	-	-	166	192	622	169	193	423
Stage 1	-	-	-	-	-	-	595	580	-	415	429	-
Stage 2	-	-	-	-	-	-	407	428	-	597	580	-
Platoon blocked, %	-	-	-	-	-	-	-	-	-	-	-	-
Mov Cap-1 Maneuver	884	-	-	1037	-	-	152	186	619	153	187	421
Mov Cap-2 Maneuver	-	-	-	-	-	-	152	186	-	153	187	-
Stage 1	-	-	-	-	-	-	584	570	-	408	424	-
Stage 2	-	-	-	-	-	-	382	423	-	551	570	-

Approach	EB	WB	NB	SB
HCM Control Delay, s	0.2	0.1	65.6	21.9
HCM LOS			F	C

Minor Lane/Major Mvmt	NBLn1	NBLn2	EBL	EBT	EBR	WBL	WBT	WBR	SBLn1
Capacity (veh/h)	153	619	884	-	-	1037	-	-	240
HCM Lane V/C Ratio	0.76	0.047	0.012	-	-	0.006	-	-	0.113
HCM Control Delay (s)	79.2	11.1	9.1	0	-	8.5	0	-	21.9
HCM Lane LOS	F	B	A	A	-	A	A	-	C
HCM 95th %tile Q(veh)	4.7	0.1	0	-	-	0	-	-	0.4

HCM 2010 Roundabout
28: Elm Street & SR-14

Intersection				
Intersection Delay, s/veh	10.7			
Intersection LOS	B			
Approach	EB	WB	NB	SB
Entry Lanes	1	1	1	1
Conflicting Circle Lanes	1	1	1	1
Adj Approach Flow, veh/h	456	434	321	54
Demand Flow Rate, veh/h	496	465	330	55
Vehicles Circulating, veh/h	38	255	466	710
Vehicles Exiting, veh/h	727	541	68	10
Follow-Up Headway, s	3.186	3.186	3.186	3.186
Ped Vol Crossing Leg, #/h	0	0	0	0
Ped Cap Adj	1.000	1.000	1.000	1.000
Approach Delay, s/veh	8.9	11.9	12.0	7.8
Approach LOS	A	B	B	A
Lane	Left	Left	Left	Left
Designated Moves	LTR	LTR	LTR	LTR
Assumed Moves	LTR	LTR	LTR	LTR
RT Channelized				
Lane Util	1.000	1.000	1.000	1.000
Critical Headway, s	5.193	5.193	5.193	5.193
Entry Flow, veh/h	496	465	330	55
Cap Entry Lane, veh/h	1088	876	709	556
Entry HV Adj Factor	0.919	0.934	0.973	0.982
Flow Entry, veh/h	456	434	321	54
Cap Entry, veh/h	1000	818	690	545
V/C Ratio	0.456	0.531	0.465	0.099
Control Delay, s/veh	8.9	11.9	12.0	7.8
LOS	A	B	B	A
95th %tile Queue, veh	2	3	2	0

HCM 2010 TWSC
1: SR-14 & SR-141

Intersection

Int Delay, s/veh 7.1

Movement	EBL	EBT	WBT	WBR	SBL	SBR
Traffic Vol, veh/h	55	290	470	220	115	60
Future Vol, veh/h	55	290	470	220	115	60
Conflicting Peds, #/hr	0	0	0	0	0	0
Sign Control	Free	Free	Free	Free	Stop	Stop
RT Channelized	-	None	-	Free	-	None
Storage Length	-	-	-	-	0	-
Veh in Median Storage, #	-	0	0	-	0	-
Grade, %	-	0	0	-	0	-
Peak Hour Factor	86	86	87	87	88	88
Heavy Vehicles, %	4	11	5	2	6	7
Mvmt Flow	64	337	540	253	131	68

Major/Minor	Major1	Major2	Minor2
Conflicting Flow All	540	0	540
Stage 1	-	-	540
Stage 2	-	-	465
Critical Hdwy	4.14	-	6.27
Critical Hdwy Stg 1	-	-	5.46
Critical Hdwy Stg 2	-	-	5.46
Follow-up Hdwy	2.236	-	3.363
Pot Cap-1 Maneuver	1018	0	532
Stage 1	-	0	576
Stage 2	-	0	624
Platoon blocked, %	-	-	-
Mov Cap-1 Maneuver	1018	-	532
Mov Cap-2 Maneuver	-	-	243
Stage 1	-	-	576
Stage 2	-	-	576

Approach	EB	WB	SB
HCM Control Delay, s	1.4	0	38
HCM LOS			E

Minor Lane/Major Mvmt	EBL	EBT	WBT	SBLn1
Capacity (veh/h)	1018	-	-	299
HCM Lane V/C Ratio	0.063	-	-	0.665
HCM Control Delay (s)	8.8	0	-	38
HCM Lane LOS	A	A	-	E
HCM 95th %tile Q(veh)	0.2	-	-	4.4

HCM 2010 TWSC
 2: SR-14 & Dock Grade Rd

Intersection												
Int Delay, s/veh	1.1											

Movement	EBL	EBT	EBR	WBL	WBT	WBR	NBL	NBT	NBR	SBL	SBT	SBR
Traffic Vol, veh/h	60	340	5	10	675	350	15	5	5	0	0	0
Future Vol, veh/h	60	340	5	10	675	350	15	5	5	0	0	0
Conflicting Peds, #/hr	0	0	0	0	0	0	0	0	0	0	0	0
Sign Control	Free	Free	Free	Free	Free	Free	Stop	Stop	Stop	Stop	Stop	Stop
RT Channelized	-	-	None	-	-	None	-	-	None	-	-	None
Storage Length	125	-	-	125	-	325	-	-	-	-	-	-
Veh in Median Storage, #	-	0	-	-	0	-	-	0	-	-	0	-
Grade, %	-	0	-	-	0	-	-	0	-	-	0	-
Peak Hour Factor	86	86	86	91	91	91	67	67	67	92	92	92
Heavy Vehicles, %	1	14	8	0	21	5	0	0	0	2	2	2
Mvmt Flow	70	395	6	11	742	385	22	7	7	0	0	0

Major/Minor	Major1			Major2			Minor1		
Conflicting Flow All	742	0	0	401	0	0	1302	1302	398
Stage 1	-	-	-	-	-	-	538	538	-
Stage 2	-	-	-	-	-	-	764	764	-
Critical Hdwy	4.11	-	-	4.1	-	-	6.4	6.5	6.2
Critical Hdwy Stg 1	-	-	-	-	-	-	5.4	5.5	-
Critical Hdwy Stg 2	-	-	-	-	-	-	5.4	5.5	-
Follow-up Hdwy	2.209	-	-	2.2	-	-	3.5	4	3.3
Pot Cap-1 Maneuver	870	-	-	1169	-	-	179	162	656
Stage 1	-	-	-	-	-	-	589	526	-
Stage 2	-	-	-	-	-	-	463	416	-
Platoon blocked, %	-	-	-	-	-	-	-	-	-
Mov Cap-1 Maneuver	870	-	-	1169	-	-	163	0	656
Mov Cap-2 Maneuver	-	-	-	-	-	-	163	0	-
Stage 1	-	-	-	-	-	-	542	0	-
Stage 2	-	-	-	-	-	-	459	0	-

Approach	EB	WB	NB
HCM Control Delay, s	1.4	0.1	26.9
HCM LOS			D

Minor Lane/Major Mvmt	NBLn1	EBL	EBT	EBR	WBL	WBT	WBR
Capacity (veh/h)	201	870	-	-	1169	-	-
HCM Lane V/C Ratio	0.186	0.08	-	-	0.009	-	-
HCM Control Delay (s)	26.9	9.5	-	-	8.1	-	-
HCM Lane LOS	D	A	-	-	A	-	-
HCM 95th %tile Q(veh)	0.7	0.3	-	-	0	-	-

HCM Signalized Intersection Capacity Analysis

3: Hood River Bridge & SR-14

	→	↘	↙	←	↖	↗
Movement	EBT	EBR	WBL	WBT	NBL	NBR
Lane Configurations	↑	↗	↘	↑	↘	↗
Traffic Volume (vph)	150	195	605	395	640	280
Future Volume (vph)	150	195	605	395	640	280
Ideal Flow (vphpl)	1900	1900	1900	1900	1900	1900
Total Lost time (s)	5.0	5.0	4.0	5.0	5.0	5.0
Lane Util. Factor	1.00	1.00	1.00	1.00	1.00	1.00
Frpb, ped/bikes	1.00	1.00	1.00	1.00	1.00	1.00
Flpb, ped/bikes	1.00	1.00	1.00	1.00	1.00	1.00
Frt	1.00	0.85	1.00	1.00	1.00	0.85
Flt Protected	1.00	1.00	0.95	1.00	0.95	1.00
Satd. Flow (prot)	1545	1509	1770	1792	1787	1553
Flt Permitted	1.00	1.00	0.95	1.00	0.95	1.00
Satd. Flow (perm)	1545	1509	1770	1792	1787	1553
Peak-hour factor, PHF	0.84	0.84	0.97	0.97	0.89	0.89
Adj. Flow (vph)	179	232	624	407	719	315
RTOR Reduction (vph)	0	28	0	0	0	77
Lane Group Flow (vph)	179	204	624	407	719	238
Confl. Peds. (#/hr)		1	1			1
Heavy Vehicles (%)	23%	7%	2%	6%	1%	4%
Turn Type	NA	pt+ov	Prot	NA	Prot	pt+ov
Protected Phases	2	2 8	1	6	8	8 1
Permitted Phases						
Actuated Green, G (s)	27.0	74.0	37.0	68.0	42.0	84.0
Effective Green, g (s)	27.0	74.0	37.0	68.0	42.0	84.0
Actuated g/C Ratio	0.22	0.62	0.31	0.57	0.35	0.70
Clearance Time (s)	5.0		4.0	5.0	5.0	
Vehicle Extension (s)	3.0		3.0	3.0	3.0	
Lane Grp Cap (vph)	347	930	545	1015	625	1087
v/s Ratio Prot	c0.12	0.14	c0.35	0.23	c0.40	0.15
v/s Ratio Perm						
v/c Ratio	0.52	0.22	1.14	0.40	1.15	0.22
Uniform Delay, d1	40.8	10.2	41.5	14.6	39.0	6.4
Progression Factor	1.00	1.00	1.00	1.00	1.00	1.00
Incremental Delay, d2	5.4	0.1	85.2	0.3	85.2	0.1
Delay (s)	46.2	10.3	126.7	14.8	124.2	6.5
Level of Service	D	B	F	B	F	A
Approach Delay (s)	25.9			82.5	88.3	
Approach LOS	C			F	F	
Intersection Summary						
HCM 2000 Control Delay			75.6		HCM 2000 Level of Service	E
HCM 2000 Volume to Capacity ratio			0.99			
Actuated Cycle Length (s)			120.0		Sum of lost time (s)	14.0
Intersection Capacity Utilization			102.3%		ICU Level of Service	G
Analysis Period (min)			15			

c Critical Lane Group

Queues

3: Hood River Bridge & SR-14

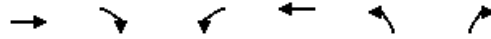

Lane Group	EBT	EBR	WBL	WBT	NBL	NBR
Lane Group Flow (vph)	179	232	624	407	719	315
v/c Ratio	0.52	0.24	1.14	0.40	1.15	0.27
Control Delay	46.9	7.6	123.6	16.1	121.5	2.0
Queue Delay	0.0	0.0	0.0	0.0	0.0	0.0
Total Delay	46.9	7.6	123.6	16.1	121.5	2.0
Queue Length 50th (ft)	122	49	~566	168	~655	13
Queue Length 95th (ft)	182	79	#792	241	#874	40
Internal Link Dist (ft)	1219			2070	431	
Turn Bay Length (ft)		250	125			125
Base Capacity (vph)	347	958	545	1015	625	1153
Starvation Cap Reductn	0	0	0	0	0	0
Spillback Cap Reductn	0	0	0	0	0	0
Storage Cap Reductn	0	0	0	0	0	0
Reduced v/c Ratio	0.52	0.24	1.14	0.40	1.15	0.27

Intersection Summary

- ~ Volume exceeds capacity, queue is theoretically infinite.
Queue shown is maximum after two cycles.
- # 95th percentile volume exceeds capacity, queue may be longer.
Queue shown is maximum after two cycles.

HCM 2010 TWSC
4: Walnut St & SR-14

Intersection												
Int Delay, s/veh	14.3											

Movement	EBL	EBT	EBR	WBL	WBT	WBR	NBL	NBT	NBR	SBL	SBT	SBR
Traffic Vol, veh/h	10	470	10	15	895	25	35	5	40	5	5	20
Future Vol, veh/h	10	470	10	15	895	25	35	5	40	5	5	20
Conflicting Peds, #/hr	13	0	12	12	0	13	6	0	11	11	0	6
Sign Control	Free	Free	Free	Free	Free	Free	Stop	Stop	Stop	Stop	Stop	Stop
RT Channelized	-	-	None	-	-	None	-	-	None	-	-	None
Storage Length	-	-	-	-	-	-	-	-	-	-	-	-
Veh in Median Storage, #	-	0	-	-	0	-	-	0	-	-	0	-
Grade, %	-	0	-	-	0	-	-	0	-	-	0	-
Peak Hour Factor	81	81	81	92	92	92	65	65	65	73	73	73
Heavy Vehicles, %	0	8	8	5	4	4	2	0	0	0	0	3
Mvmt Flow	12	580	12	16	973	27	54	8	62	7	7	27

Major/Minor	Major1			Major2			Minor1			Minor2		
Conflicting Flow All	1011	0	0	604	0	0	1669	1666	610	1687	1658	1010
Stage 1	-	-	-	-	-	-	622	622	-	1030	1030	-
Stage 2	-	-	-	-	-	-	1047	1044	-	657	628	-
Critical Hdwy	4.1	-	-	4.15	-	-	7.12	6.5	6.2	7.1	6.5	6.23
Critical Hdwy Stg 1	-	-	-	-	-	-	6.12	5.5	-	6.1	5.5	-
Critical Hdwy Stg 2	-	-	-	-	-	-	6.12	5.5	-	6.1	5.5	-
Follow-up Hdwy	2.2	-	-	2.245	-	-	3.518	4	3.3	3.5	4	3.327
Pot Cap-1 Maneuver	694	-	-	959	-	-	76	98	498	75	99	290
Stage 1	-	-	-	-	-	-	474	482	-	284	313	-
Stage 2	-	-	-	-	-	-	276	309	-	457	479	-
Platoon blocked, %	-	-	-	-	-	-	-	-	-	-	-	-
Mov Cap-1 Maneuver	685	-	-	947	-	-	60	90	487	57	91	283
Mov Cap-2 Maneuver	-	-	-	-	-	-	60	90	-	57	91	-
Stage 1	-	-	-	-	-	-	457	465	-	274	298	-
Stage 2	-	-	-	-	-	-	231	294	-	378	462	-

Approach	EB	WB	NB	SB
HCM Control Delay, s	0.2	0.1	191.5	40.7
HCM LOS			F	E

Minor Lane/Major Mvmt	NBLn1	EBL	EBT	EBR	WBL	WBT	WBR	SBLn1
Capacity (veh/h)	111	685	-	-	947	-	-	141
HCM Lane V/C Ratio	1.109	0.018	-	-	0.017	-	-	0.291
HCM Control Delay (s)	191.5	10.4	0	-	8.9	0	-	40.7
HCM Lane LOS	F	B	A	-	A	A	-	E
HCM 95th %tile Q(veh)	7.6	0.1	-	-	0.1	-	-	1.1

HCM 2010 TWSC
5: Ash St & SR-14

Intersection												
Int Delay, s/veh	3.9											

Movement	EBL	EBT	EBR	WBL	WBT	WBR	NBL	NBT	NBR	SBL	SBT	SBR
Traffic Vol, veh/h	25	485	10	5	850	10	0	0	0	20	0	80
Future Vol, veh/h	25	485	10	5	850	10	0	0	0	20	0	80
Conflicting Peds, #/hr	3	0	9	9	0	3	8	0	8	8	0	8
Sign Control	Free	Free	Free	Free	Free	Free	Stop	Stop	Stop	Stop	Stop	Stop
RT Channelized	-	-	None	-	-	None	-	-	None	-	-	None
Storage Length	-	-	-	-	-	-	-	-	-	-	-	-
Veh in Median Storage, #	-	0	-	-	0	-	-	0	-	-	0	-
Grade, %	-	0	-	-	0	-	-	0	-	-	0	-
Peak Hour Factor	90	90	90	88	88	88	92	92	92	73	73	73
Heavy Vehicles, %	7	6	0	0	5	0	2	2	2	8	0	0
Mvmt Flow	28	539	11	6	966	11	0	0	0	27	0	110

Major/Minor	Major1			Major2			Minor2		
Conflicting Flow All	985	0	0	550	0	0	1591	1597	989
Stage 1	-	-	-	-	-	-	991	991	-
Stage 2	-	-	-	-	-	-	600	606	-
Critical Hdwy	4.17	-	-	4.1	-	-	6.48	6.5	6.2
Critical Hdwy Stg 1	-	-	-	-	-	-	5.48	5.5	-
Critical Hdwy Stg 2	-	-	-	-	-	-	5.48	5.5	-
Follow-up Hdwy	2.263	-	-	2.2	-	-	3.572	4	3.3
Pot Cap-1 Maneuver	682	-	-	1030	-	-	114	108	302
Stage 1	-	-	-	-	-	-	350	327	-
Stage 2	-	-	-	-	-	-	537	490	-
Platoon blocked, %	-	-	-	-	-	-	-	-	-
Mov Cap-1 Maneuver	676	-	-	1021	-	-	104	0	297
Mov Cap-2 Maneuver	-	-	-	-	-	-	104	0	-
Stage 1	-	-	-	-	-	-	343	0	-
Stage 2	-	-	-	-	-	-	501	0	-

Approach	EB	WB	SB
HCM Control Delay, s	0.5	0	46.3
HCM LOS			E

Minor Lane/Major Mvmt	EBL	EBT	EBR	WBL	WBT	WBR	SBLn1
Capacity (veh/h)	676	-	-	1021	-	-	217
HCM Lane V/C Ratio	0.041	-	-	0.006	-	-	0.631
HCM Control Delay (s)	10.6	0	-	8.5	0	-	46.3
HCM Lane LOS	B	A	-	A	A	-	E
HCM 95th %tile Q(veh)	0.1	-	-	0	-	-	3.7

HCM 2010 Roundabout
6: Oak St & SR-14

Intersection				
Intersection Delay, s/veh	45.3			
Intersection LOS	E			
Approach	EB	WB	NB	SB
Entry Lanes	1	1	1	1
Conflicting Circle Lanes	1	1	1	1
Adj Approach Flow, veh/h	646	816	72	561
Demand Flow Rate, veh/h	705	858	76	571
Vehicles Circulating, veh/h	140	326	814	608
Vehicles Exiting, veh/h	1039	564	30	576
Follow-Up Headway, s	3.186	3.186	3.186	3.186
Ped Vol Crossing Leg, #/h	2	1	7	6
Ped Cap Adj	1.000	1.000	0.999	0.999
Approach Delay, s/veh	17.1	69.7	9.7	47.0
Approach LOS	C	F	A	E
Lane	Left	Left	Left	Left
Designated Moves	LTR	LTR	LTR	LTR
Assumed Moves	LTR	LTR	LTR	LTR
RT Channelized				
Lane Util	1.000	1.000	1.000	1.000
Critical Headway, s	5.193	5.193	5.193	5.193
Entry Flow, veh/h	705	858	76	571
Cap Entry Lane, veh/h	982	816	501	615
Entry HV Adj Factor	0.916	0.951	0.948	0.982
Flow Entry, veh/h	646	816	72	561
Cap Entry, veh/h	900	775	474	604
V/C Ratio	0.718	1.052	0.152	0.929
Control Delay, s/veh	17.1	69.7	9.7	47.0
LOS	C	F	A	E
95th %tile Queue, veh	6	20	1	12

HCM 2010 TWSC
7: Maple St & SR-14

Intersection												
Int Delay, s/veh	7.6											

Movement	EBL	EBT	EBR	WBL	WBT	WBR	NBL	NBT	NBR	SBL	SBT	SBR
Traffic Vol, veh/h	10	385	20	5	625	5	95	5	25	5	5	10
Future Vol, veh/h	10	385	20	5	625	5	95	5	25	5	5	10
Conflicting Peds, #/hr	4	0	2	2	0	4	1	0	1	1	0	1
Sign Control	Free	Free	Free	Free	Free	Free	Stop	Stop	Stop	Stop	Stop	Stop
RT Channelized	-	-	None	-	-	None	-	-	None	-	-	None
Storage Length	-	-	80	-	-	-	-	-	0	-	-	-
Veh in Median Storage, #	-	0	-	-	0	-	-	0	-	-	0	-
Grade, %	-	0	-	-	0	-	-	0	-	-	0	-
Peak Hour Factor	92	92	92	87	87	87	86	86	86	74	74	74
Heavy Vehicles, %	0	9	7	22	7	0	2	0	6	0	0	3
Mvmt Flow	11	418	22	6	718	6	110	6	29	7	7	14

Major/Minor	Major1			Major2			Minor1			Minor2		
Conflicting Flow All	725	0	0	419	0	0	1185	1178	423	1178	1175	726
Stage 1	-	-	-	-	-	-	441	441	-	734	734	-
Stage 2	-	-	-	-	-	-	744	737	-	444	441	-
Critical Hdwy	4.1	-	-	4.32	-	-	7.12	6.5	6.26	7.1	6.5	6.23
Critical Hdwy Stg 1	-	-	-	-	-	-	6.12	5.5	-	6.1	5.5	-
Critical Hdwy Stg 2	-	-	-	-	-	-	6.12	5.5	-	6.1	5.5	-
Follow-up Hdwy	2.2	-	-	2.398	-	-	3.518	4	3.354	3.5	4	3.327
Pot Cap-1 Maneuver	887	-	-	1041	-	-	166	192	622	169	193	423
Stage 1	-	-	-	-	-	-	595	580	-	415	429	-
Stage 2	-	-	-	-	-	-	407	428	-	597	580	-
Platoon blocked, %	-	-	-	-	-	-	-	-	-	-	-	-
Mov Cap-1 Maneuver	884	-	-	1037	-	-	152	186	619	153	187	421
Mov Cap-2 Maneuver	-	-	-	-	-	-	152	186	-	153	187	-
Stage 1	-	-	-	-	-	-	584	570	-	408	424	-
Stage 2	-	-	-	-	-	-	382	423	-	551	570	-

Approach	EB	WB	NB	SB
HCM Control Delay, s	0.2	0.1	65.6	21.9
HCM LOS			F	C

Minor Lane/Major Mvmt	NBLn1	NBLn2	EBL	EBT	EBR	WBL	WBT	WBR	SBLn1
Capacity (veh/h)	153	619	884	-	-	1037	-	-	240
HCM Lane V/C Ratio	0.76	0.047	0.012	-	-	0.006	-	-	0.113
HCM Control Delay (s)	79.2	11.1	9.1	0	-	8.5	0	-	21.9
HCM Lane LOS	F	B	A	A	-	A	A	-	C
HCM 95th %tile Q(veh)	4.7	0.1	0	-	-	0	-	-	0.4

HCM 2010 Roundabout
28: SR-14

Intersection				
Intersection Delay, s/veh	10.7			
Intersection LOS	B			
Approach	EB	WB	NB	SB
Entry Lanes	1	1	1	1
Conflicting Circle Lanes	1	1	1	1
Adj Approach Flow, veh/h	456	434	321	54
Demand Flow Rate, veh/h	496	465	330	55
Vehicles Circulating, veh/h	38	255	466	710
Vehicles Exiting, veh/h	727	541	68	10
Follow-Up Headway, s	3.186	3.186	3.186	3.186
Ped Vol Crossing Leg, #/h	0	0	0	0
Ped Cap Adj	1.000	1.000	1.000	1.000
Approach Delay, s/veh	8.9	11.9	12.0	7.8
Approach LOS	A	B	B	A
Lane	Left	Left	Left	Left
Designated Moves	LTR	LTR	LTR	LTR
Assumed Moves	LTR	LTR	LTR	LTR
RT Channelized				
Lane Util	1.000	1.000	1.000	1.000
Critical Headway, s	5.193	5.193	5.193	5.193
Entry Flow, veh/h	496	465	330	55
Cap Entry Lane, veh/h	1088	876	709	556
Entry HV Adj Factor	0.919	0.934	0.973	0.982
Flow Entry, veh/h	456	434	321	54
Cap Entry, veh/h	1000	818	690	545
V/C Ratio	0.456	0.531	0.465	0.099
Control Delay, s/veh	8.9	11.9	12.0	7.8
LOS	A	B	B	A
95th %tile Queue, veh	2	3	2	0

HCM 2010 TWSC
1: SR-14 & SR-141

Intersection

Int Delay, s/veh 7.1

Movement	EBL	EBT	WBT	WBR	SBL	SBR
Traffic Vol, veh/h	55	290	470	220	115	60
Future Vol, veh/h	55	290	470	220	115	60
Conflicting Peds, #/hr	0	0	0	0	0	0
Sign Control	Free	Free	Free	Free	Stop	Stop
RT Channelized	-	None	-	Free	-	None
Storage Length	-	-	-	-	0	-
Veh in Median Storage, #	-	0	0	-	0	-
Grade, %	-	0	0	-	0	-
Peak Hour Factor	86	86	87	87	88	88
Heavy Vehicles, %	4	11	5	2	6	7
Mvmt Flow	64	337	540	253	131	68

Major/Minor	Major1	Major2	Minor2
Conflicting Flow All	540	0	540
Stage 1	-	-	540
Stage 2	-	-	465
Critical Hdwy	4.14	-	6.27
Critical Hdwy Stg 1	-	-	5.46
Critical Hdwy Stg 2	-	-	5.46
Follow-up Hdwy	2.236	-	3.363
Pot Cap-1 Maneuver	1018	-	532
Stage 1	-	-	576
Stage 2	-	-	624
Platoon blocked, %	-	-	-
Mov Cap-1 Maneuver	1018	-	532
Mov Cap-2 Maneuver	-	-	-
Stage 1	-	-	576
Stage 2	-	-	576

Approach	EB	WB	SB
HCM Control Delay, s	1.4	0	38
HCM LOS			E

Minor Lane/Major Mvmt	EBL	EBT	WBT	SBLn1
Capacity (veh/h)	1018	-	-	299
HCM Lane V/C Ratio	0.063	-	-	0.665
HCM Control Delay (s)	8.8	0	-	38
HCM Lane LOS	A	A	-	E
HCM 95th %tile Q(veh)	0.2	-	-	4.4

HCM 2010 TWSC
 2: SR-14 & Dock Grade Rd

Intersection

Int Delay, s/veh 1.1

Movement	EBL	EBT	EBR	WBL	WBT	WBR	NBL	NBT	NBR	SBL	SBT	SBR
Traffic Vol, veh/h	60	340	5	10	675	350	15	5	5	0	0	0
Future Vol, veh/h	60	340	5	10	675	350	15	5	5	0	0	0
Conflicting Peds, #/hr	0	0	0	0	0	0	0	0	0	0	0	0
Sign Control	Free	Free	Free	Free	Free	Free	Stop	Stop	Stop	Stop	Stop	Stop
RT Channelized	-	-	None	-	-	None	-	-	None	-	-	None
Storage Length	125	-	-	125	-	325	-	-	-	-	-	-
Veh in Median Storage, #	-	0	-	-	0	-	-	0	-	-	0	-
Grade, %	-	0	-	-	0	-	-	0	-	-	0	-
Peak Hour Factor	86	86	86	91	91	91	67	67	67	92	92	92
Heavy Vehicles, %	1	14	8	0	21	5	0	0	0	2	2	2
Mvmt Flow	70	395	6	11	742	385	22	7	7	0	0	0

Major/Minor	Major1			Major2			Minor1		
Conflicting Flow All	742	0	0	401	0	0	1302	1302	398
Stage 1	-	-	-	-	-	-	538	538	-
Stage 2	-	-	-	-	-	-	764	764	-
Critical Hdwy	4.11	-	-	4.1	-	-	6.4	6.5	6.2
Critical Hdwy Stg 1	-	-	-	-	-	-	5.4	5.5	-
Critical Hdwy Stg 2	-	-	-	-	-	-	5.4	5.5	-
Follow-up Hdwy	2.209	-	-	2.2	-	-	3.5	4	3.3
Pot Cap-1 Maneuver	870	-	-	1169	-	-	179	162	656
Stage 1	-	-	-	-	-	-	589	526	-
Stage 2	-	-	-	-	-	-	463	416	-
Platoon blocked, %	-	-	-	-	-	-	-	-	-
Mov Cap-1 Maneuver	870	-	-	1169	-	-	163	0	656
Mov Cap-2 Maneuver	-	-	-	-	-	-	163	0	-
Stage 1	-	-	-	-	-	-	542	0	-
Stage 2	-	-	-	-	-	-	459	0	-

Approach	EB		WB		NB
HCM Control Delay, s	1.4		0.1		26.9
HCM LOS					D

Minor Lane/Major Mvmt	NBLn1	EBL	EBT	EBR	WBL	WBT	WBR
Capacity (veh/h)	201	870	-	-	1169	-	-
HCM Lane V/C Ratio	0.186	0.08	-	-	0.009	-	-
HCM Control Delay (s)	26.9	9.5	-	-	8.1	-	-
HCM Lane LOS	D	A	-	-	A	-	-
HCM 95th %tile Q(veh)	0.7	0.3	-	-	0	-	-

HCM Signalized Intersection Capacity Analysis

3: Hood River Bridge & SR-14

	→	↘	↙	←	↖	↗
Movement	EBT	EBR	WBL	WBT	NBL	NBR
Lane Configurations	↑	↗	↘	↑	↘	↗
Traffic Volume (vph)	150	195	605	395	640	280
Future Volume (vph)	150	195	605	395	640	280
Ideal Flow (vphpl)	1900	1900	1900	1900	1900	1900
Total Lost time (s)	5.0	5.0	4.0	5.0	5.0	5.0
Lane Util. Factor	1.00	1.00	1.00	1.00	1.00	1.00
Frpb, ped/bikes	1.00	1.00	1.00	1.00	1.00	1.00
Flpb, ped/bikes	1.00	1.00	1.00	1.00	1.00	1.00
Frt	1.00	0.85	1.00	1.00	1.00	0.85
Flt Protected	1.00	1.00	0.95	1.00	0.95	1.00
Satd. Flow (prot)	1545	1509	1770	1792	1787	1553
Flt Permitted	1.00	1.00	0.95	1.00	0.95	1.00
Satd. Flow (perm)	1545	1509	1770	1792	1787	1553
Peak-hour factor, PHF	0.84	0.84	0.97	0.97	0.89	0.89
Adj. Flow (vph)	179	232	624	407	719	315
RTOR Reduction (vph)	0	28	0	0	0	77
Lane Group Flow (vph)	179	204	624	407	719	238
Confl. Peds. (#/hr)		1	1			1
Heavy Vehicles (%)	23%	7%	2%	6%	1%	4%
Turn Type	NA	pt+ov	Prot	NA	Prot	pt+ov
Protected Phases	2	2 8	1	6	8	8 1
Permitted Phases						
Actuated Green, G (s)	27.0	74.0	37.0	68.0	42.0	84.0
Effective Green, g (s)	27.0	74.0	37.0	68.0	42.0	84.0
Actuated g/C Ratio	0.22	0.62	0.31	0.57	0.35	0.70
Clearance Time (s)	5.0		4.0	5.0	5.0	
Vehicle Extension (s)	3.0		3.0	3.0	3.0	
Lane Grp Cap (vph)	347	930	545	1015	625	1087
v/s Ratio Prot	c0.12	0.14	c0.35	0.23	c0.40	0.15
v/s Ratio Perm						
v/c Ratio	0.52	0.22	1.14	0.40	1.15	0.22
Uniform Delay, d1	40.8	10.2	41.5	14.6	39.0	6.4
Progression Factor	1.00	1.00	1.00	1.00	1.00	1.00
Incremental Delay, d2	5.4	0.1	85.2	0.3	85.2	0.1
Delay (s)	46.2	10.3	126.7	14.8	124.2	6.5
Level of Service	D	B	F	B	F	A
Approach Delay (s)	25.9			82.5	88.3	
Approach LOS	C			F	F	
Intersection Summary						
HCM 2000 Control Delay			75.6		HCM 2000 Level of Service	E
HCM 2000 Volume to Capacity ratio			0.99			
Actuated Cycle Length (s)			120.0		Sum of lost time (s)	14.0
Intersection Capacity Utilization			102.3%		ICU Level of Service	G
Analysis Period (min)			15			

c Critical Lane Group

Queues

3: Hood River Bridge & SR-14

	→	↘	↙	←	↖	↗
Lane Group	EBT	EBR	WBL	WBT	NBL	NBR
Lane Group Flow (vph)	179	232	624	407	719	315
v/c Ratio	0.52	0.24	1.14	0.40	1.15	0.27
Control Delay	46.9	7.6	123.6	16.1	121.5	2.0
Queue Delay	0.0	0.0	0.0	0.0	0.0	0.0
Total Delay	46.9	7.6	123.6	16.1	121.5	2.0
Queue Length 50th (ft)	122	49	~566	168	~655	13
Queue Length 95th (ft)	182	79	#792	241	#874	40
Internal Link Dist (ft)	1219			2070	431	
Turn Bay Length (ft)		250	125			125
Base Capacity (vph)	347	958	545	1015	625	1153
Starvation Cap Reductn	0	0	0	0	0	0
Spillback Cap Reductn	0	0	0	0	0	0
Storage Cap Reductn	0	0	0	0	0	0
Reduced v/c Ratio	0.52	0.24	1.14	0.40	1.15	0.27

Intersection Summary

- ~ Volume exceeds capacity, queue is theoretically infinite.
Queue shown is maximum after two cycles.
- # 95th percentile volume exceeds capacity, queue may be longer.
Queue shown is maximum after two cycles.

HCM 2010 TWSC
4: Walnut St & SR-14

Intersection												
Int Delay, s/veh	14.3											

Movement	EBL	EBT	EBR	WBL	WBT	WBR	NBL	NBT	NBR	SBL	SBT	SBR
Traffic Vol, veh/h	10	470	10	15	895	25	35	5	40	5	5	20
Future Vol, veh/h	10	470	10	15	895	25	35	5	40	5	5	20
Conflicting Peds, #/hr	13	0	12	12	0	13	6	0	11	11	0	6
Sign Control	Free	Free	Free	Free	Free	Free	Stop	Stop	Stop	Stop	Stop	Stop
RT Channelized	-	-	None	-	-	None	-	-	None	-	-	None
Storage Length	-	-	-	-	-	-	-	-	-	-	-	-
Veh in Median Storage, #	-	0	-	-	0	-	-	0	-	-	0	-
Grade, %	-	0	-	-	0	-	-	0	-	-	0	-
Peak Hour Factor	81	81	81	92	92	92	65	65	65	73	73	73
Heavy Vehicles, %	0	8	8	5	4	4	2	0	0	0	0	3
Mvmt Flow	12	580	12	16	973	27	54	8	62	7	7	27

Major/Minor	Major1			Major2			Minor1			Minor2		
Conflicting Flow All	1011	0	0	604	0	0	1669	1666	610	1687	1658	1010
Stage 1	-	-	-	-	-	-	622	622	-	1030	1030	-
Stage 2	-	-	-	-	-	-	1047	1044	-	657	628	-
Critical Hdwy	4.1	-	-	4.15	-	-	7.12	6.5	6.2	7.1	6.5	6.23
Critical Hdwy Stg 1	-	-	-	-	-	-	6.12	5.5	-	6.1	5.5	-
Critical Hdwy Stg 2	-	-	-	-	-	-	6.12	5.5	-	6.1	5.5	-
Follow-up Hdwy	2.2	-	-	2.245	-	-	3.518	4	3.3	3.5	4	3.327
Pot Cap-1 Maneuver	694	-	-	959	-	-	76	98	498	75	99	290
Stage 1	-	-	-	-	-	-	474	482	-	284	313	-
Stage 2	-	-	-	-	-	-	276	309	-	457	479	-
Platoon blocked, %	-	-	-	-	-	-	-	-	-	-	-	-
Mov Cap-1 Maneuver	685	-	-	947	-	-	60	90	487	57	91	283
Mov Cap-2 Maneuver	-	-	-	-	-	-	60	90	-	57	91	-
Stage 1	-	-	-	-	-	-	457	465	-	274	298	-
Stage 2	-	-	-	-	-	-	231	294	-	378	462	-

Approach	EB	WB	NB	SB
HCM Control Delay, s	0.2	0.1	191.5	40.7
HCM LOS			F	E

Minor Lane/Major Mvmt	NBLn1	EBL	EBT	EBR	WBL	WBT	WBR	SBLn1
Capacity (veh/h)	111	685	-	-	947	-	-	141
HCM Lane V/C Ratio	1.109	0.018	-	-	0.017	-	-	0.291
HCM Control Delay (s)	191.5	10.4	0	-	8.9	0	-	40.7
HCM Lane LOS	F	B	A	-	A	A	-	E
HCM 95th %tile Q(veh)	7.6	0.1	-	-	0.1	-	-	1.1

HCM 2010 TWSC
5: Ash St & SR-14

Intersection												
Int Delay, s/veh	3.9											

Movement	EBL	EBT	EBR	WBL	WBT	WBR	NBL	NBT	NBR	SBL	SBT	SBR
Traffic Vol, veh/h	25	485	10	5	850	10	0	0	0	20	0	80
Future Vol, veh/h	25	485	10	5	850	10	0	0	0	20	0	80
Conflicting Peds, #/hr	3	0	9	9	0	3	8	0	8	8	0	8
Sign Control	Free	Free	Free	Free	Free	Free	Stop	Stop	Stop	Stop	Stop	Stop
RT Channelized	-	-	None	-	-	None	-	-	None	-	-	None
Storage Length	-	-	-	-	-	-	-	-	-	-	-	-
Veh in Median Storage, #	-	0	-	-	0	-	-	0	-	-	0	-
Grade, %	-	0	-	-	0	-	-	0	-	-	0	-
Peak Hour Factor	90	90	90	88	88	88	92	92	92	73	73	73
Heavy Vehicles, %	7	6	0	0	5	0	2	2	2	8	0	0
Mvmt Flow	28	539	11	6	966	11	0	0	0	27	0	110

Major/Minor	Major1			Major2			Minor2		
Conflicting Flow All	985	0	0	550	0	0	1591	1597	989
Stage 1	-	-	-	-	-	-	991	991	-
Stage 2	-	-	-	-	-	-	600	606	-
Critical Hdwy	4.17	-	-	4.1	-	-	6.48	6.5	6.2
Critical Hdwy Stg 1	-	-	-	-	-	-	5.48	5.5	-
Critical Hdwy Stg 2	-	-	-	-	-	-	5.48	5.5	-
Follow-up Hdwy	2.263	-	-	2.2	-	-	3.572	4	3.3
Pot Cap-1 Maneuver	682	-	-	1030	-	-	114	108	302
Stage 1	-	-	-	-	-	-	350	327	-
Stage 2	-	-	-	-	-	-	537	490	-
Platoon blocked, %	-	-	-	-	-	-	-	-	-
Mov Cap-1 Maneuver	676	-	-	1021	-	-	104	0	297
Mov Cap-2 Maneuver	-	-	-	-	-	-	104	0	-
Stage 1	-	-	-	-	-	-	343	0	-
Stage 2	-	-	-	-	-	-	501	0	-

Approach	EB	WB	SB
HCM Control Delay, s	0.5	0	46.3
HCM LOS			E

Minor Lane/Major Mvmt	EBL	EBT	EBR	WBL	WBT	WBR	SBLn1
Capacity (veh/h)	676	-	-	1021	-	-	217
HCM Lane V/C Ratio	0.041	-	-	0.006	-	-	0.631
HCM Control Delay (s)	10.6	0	-	8.5	0	-	46.3
HCM Lane LOS	B	A	-	A	A	-	E
HCM 95th %tile Q(veh)	0.1	-	-	0	-	-	3.7

HCM 2010 Roundabout

6: Oak St & SR-14

Intersection				
Intersection Delay, s/veh	45.3			
Intersection LOS	E			
Approach	EB	WB	NB	SB
Entry Lanes	1	1	1	1
Conflicting Circle Lanes	1	1	1	1
Adj Approach Flow, veh/h	646	816	72	561
Demand Flow Rate, veh/h	705	858	76	571
Vehicles Circulating, veh/h	140	326	814	608
Vehicles Exiting, veh/h	1039	564	30	576
Follow-Up Headway, s	3.186	3.186	3.186	3.186
Ped Vol Crossing Leg, #/h	2	1	7	6
Ped Cap Adj	1.000	1.000	0.999	0.999
Approach Delay, s/veh	17.1	69.7	9.7	47.0
Approach LOS	C	F	A	E
Lane	Left	Left	Left	Left
Designated Moves	LTR	LTR	LTR	LTR
Assumed Moves	LTR	LTR	LTR	LTR
RT Channelized				
Lane Util	1.000	1.000	1.000	1.000
Critical Headway, s	5.193	5.193	5.193	5.193
Entry Flow, veh/h	705	858	76	571
Cap Entry Lane, veh/h	982	816	501	615
Entry HV Adj Factor	0.916	0.951	0.948	0.982
Flow Entry, veh/h	646	816	72	561
Cap Entry, veh/h	900	775	474	604
V/C Ratio	0.718	1.052	0.152	0.929
Control Delay, s/veh	17.1	69.7	9.7	47.0
LOS	C	F	A	E
95th %tile Queue, veh	6	20	1	12

HCM 2010 TWSC
7: Maple St & SR-14

Intersection

Int Delay, s/veh 1.7

Movement	EBL	EBT	EBR	WBL	WBT	WBR	NBL	NBT	NBR	SBL	SBT	SBR
Traffic Vol, veh/h	10	390	15	0	695	5	25	0	10	5	5	10
Future Vol, veh/h	10	390	15	0	695	5	25	0	10	5	5	10
Conflicting Peds, #/hr	4	0	2	2	0	4	1	0	1	1	0	1
Sign Control	Free	Free	Free	Free	Free	Free	Stop	Stop	Stop	Stop	Stop	Stop
RT Channelized	-	-	None	-	-	None	-	-	None	-	-	None
Storage Length	-	-	80	-	-	-	-	-	0	-	-	-
Veh in Median Storage, #	-	0	-	-	0	-	-	0	-	-	0	-
Grade, %	-	0	-	-	0	-	-	0	-	-	0	-
Peak Hour Factor	92	92	92	87	87	87	86	86	86	74	74	74
Heavy Vehicles, %	0	9	64	64	7	0	34	0	34	0	0	3
Mvmt Flow	11	424	16	0	799	6	29	0	12	7	7	14

Major/Minor	Major1			Major2			Minor1			Minor2		
Conflicting Flow All	806	0	0	425	0	0	1260	1253	429	1250	1250	807
Stage 1	-	-	-	-	-	-	447	447	-	803	803	-
Stage 2	-	-	-	-	-	-	813	806	-	447	447	-
Critical Hdwy	4.1	-	-	4.74	-	-	7.44	6.5	6.54	7.1	6.5	6.23
Critical Hdwy Stg 1	-	-	-	-	-	-	6.44	5.5	-	6.1	5.5	-
Critical Hdwy Stg 2	-	-	-	-	-	-	6.44	5.5	-	6.1	5.5	-
Follow-up Hdwy	2.2	-	-	2.776	-	-	3.806	4	3.606	3.5	4	3.327
Pot Cap-1 Maneuver	828	-	-	869	-	-	127	174	563	151	174	380
Stage 1	-	-	-	-	-	-	534	577	-	380	399	-
Stage 2	-	-	-	-	-	-	329	398	-	595	577	-
Platoon blocked, %	-	-	-	-	-	-	-	-	-	-	-	-
Mov Cap-1 Maneuver	825	-	-	866	-	-	117	171	560	145	171	378
Mov Cap-2 Maneuver	-	-	-	-	-	-	117	171	-	145	171	-
Stage 1	-	-	-	-	-	-	524	566	-	373	399	-
Stage 2	-	-	-	-	-	-	311	398	-	570	566	-

Approach	EB	WB	NB	SB
HCM Control Delay, s	0.2	0	36	23.5
HCM LOS			E	C

Minor Lane/Major Mvmt	NBLn1	NBLn2	EBL	EBT	EBR	WBL	WBT	WBR	SBLn1
Capacity (veh/h)	117	560	825	-	-	866	-	-	222
HCM Lane V/C Ratio	0.248	0.021	0.013	-	-	-	-	-	0.122
HCM Control Delay (s)	45.7	11.6	9.4	0	-	0	-	-	23.5
HCM Lane LOS	E	B	A	A	-	A	-	-	C
HCM 95th %tile Q(veh)	0.9	0.1	0	-	-	0	-	-	0.4

HCM 2010 Roundabout
28: SR-14

Intersection				
Intersection Delay, s/veh	12.3			
Intersection LOS	B			
Approach	EB	WB	NB	SB
Entry Lanes	1	1	1	1
Conflicting Circle Lanes	1	1	1	1
Adj Approach Flow, veh/h	440	440	424	54
Demand Flow Rate, veh/h	475	470	428	55
Vehicles Circulating, veh/h	43	335	442	789
Vehicles Exiting, veh/h	801	535	76	16
Follow-Up Headway, s	3.186	3.186	3.186	3.186
Ped Vol Crossing Leg, #/h	0	0	0	0
Ped Cap Adj	1.000	1.000	1.000	1.000
Approach Delay, s/veh	8.6	14.1	14.9	8.5
Approach LOS	A	B	B	A
Lane	Left	Left	Left	Left
Designated Moves	LTR	LTR	LTR	LTR
Assumed Moves	LTR	LTR	LTR	LTR
RT Channelized				
Lane Util	1.000	1.000	1.000	1.000
Critical Headway, s	5.193	5.193	5.193	5.193
Entry Flow, veh/h	475	470	428	55
Cap Entry Lane, veh/h	1082	808	726	513
Entry HV Adj Factor	0.926	0.937	0.991	0.982
Flow Entry, veh/h	440	440	424	54
Cap Entry, veh/h	1002	757	719	504
V/C Ratio	0.439	0.581	0.589	0.107
Control Delay, s/veh	8.6	14.1	14.9	8.5
LOS	A	B	B	A
95th %tile Queue, veh	2	4	4	0

HCM 2010 TWSC
1: SR-14 & SR-141

Intersection

Int Delay, s/veh 7.1

Movement	EBL	EBT	WBT	WBR	SBL	SBR
Traffic Vol, veh/h	55	290	470	220	115	60
Future Vol, veh/h	55	290	470	220	115	60
Conflicting Peds, #/hr	0	0	0	0	0	0
Sign Control	Free	Free	Free	Free	Stop	Stop
RT Channelized	-	None	-	Free	-	None
Storage Length	-	-	-	-	0	-
Veh in Median Storage, #	-	0	0	-	0	-
Grade, %	-	0	0	-	0	-
Peak Hour Factor	86	86	87	87	88	88
Heavy Vehicles, %	4	11	5	2	6	7
Mvmt Flow	64	337	540	253	131	68

Major/Minor	Major1	Major2	Minor2
Conflicting Flow All	540	0	540
Stage 1	-	-	540
Stage 2	-	-	465
Critical Hdwy	4.14	-	6.27
Critical Hdwy Stg 1	-	-	5.46
Critical Hdwy Stg 2	-	-	5.46
Follow-up Hdwy	2.236	-	3.363
Pot Cap-1 Maneuver	1018	0	532
Stage 1	-	0	576
Stage 2	-	0	624
Platoon blocked, %	-	-	-
Mov Cap-1 Maneuver	1018	-	532
Mov Cap-2 Maneuver	-	-	243
Stage 1	-	-	576
Stage 2	-	-	576

Approach	EB	WB	SB
HCM Control Delay, s	1.4	0	38
HCM LOS			E

Minor Lane/Major Mvmt	EBL	EBT	WBT	SBLn1
Capacity (veh/h)	1018	-	-	299
HCM Lane V/C Ratio	0.063	-	-	0.665
HCM Control Delay (s)	8.8	0	-	38
HCM Lane LOS	A	A	-	E
HCM 95th %tile Q(veh)	0.2	-	-	4.4

HCM 2010 TWSC
 2: SR-14 & Dock Grade Rd

Intersection

Int Delay, s/veh 1.1

Movement	EBL	EBT	EBR	WBL	WBT	WBR	NBL	NBT	NBR	SBL	SBT	SBR
Traffic Vol, veh/h	60	340	5	10	675	350	15	5	5	0	0	0
Future Vol, veh/h	60	340	5	10	675	350	15	5	5	0	0	0
Conflicting Peds, #/hr	0	0	0	0	0	0	0	0	0	0	0	0
Sign Control	Free	Free	Free	Free	Free	Free	Stop	Stop	Stop	Stop	Stop	Stop
RT Channelized	-	-	None	-	-	None	-	-	None	-	-	None
Storage Length	125	-	-	125	-	325	-	-	-	-	-	-
Veh in Median Storage, #	-	0	-	-	0	-	-	0	-	-	0	-
Grade, %	-	0	-	-	0	-	-	0	-	-	0	-
Peak Hour Factor	86	86	86	91	91	91	67	67	67	92	92	92
Heavy Vehicles, %	1	14	8	0	21	5	0	0	0	2	2	2
Mvmt Flow	70	395	6	11	742	385	22	7	7	0	0	0

Major/Minor	Major1			Major2			Minor1		
Conflicting Flow All	742	0	0	401	0	0	1302	1302	398
Stage 1	-	-	-	-	-	-	538	538	-
Stage 2	-	-	-	-	-	-	764	764	-
Critical Hdwy	4.11	-	-	4.1	-	-	6.4	6.5	6.2
Critical Hdwy Stg 1	-	-	-	-	-	-	5.4	5.5	-
Critical Hdwy Stg 2	-	-	-	-	-	-	5.4	5.5	-
Follow-up Hdwy	2.209	-	-	2.2	-	-	3.5	4	3.3
Pot Cap-1 Maneuver	870	-	-	1169	-	-	179	162	656
Stage 1	-	-	-	-	-	-	589	526	-
Stage 2	-	-	-	-	-	-	463	416	-
Platoon blocked, %	-	-	-	-	-	-	-	-	-
Mov Cap-1 Maneuver	870	-	-	1169	-	-	163	0	656
Mov Cap-2 Maneuver	-	-	-	-	-	-	163	0	-
Stage 1	-	-	-	-	-	-	542	0	-
Stage 2	-	-	-	-	-	-	459	0	-

Approach	EB	WB	NB
HCM Control Delay, s	1.4	0.1	26.9
HCM LOS			D

Minor Lane/Major Mvmt	NBLn1	EBL	EBT	EBR	WBL	WBT	WBR
Capacity (veh/h)	201	870	-	-	1169	-	-
HCM Lane V/C Ratio	0.186	0.08	-	-	0.009	-	-
HCM Control Delay (s)	26.9	9.5	-	-	8.1	-	-
HCM Lane LOS	D	A	-	-	A	-	-
HCM 95th %tile Q(veh)	0.7	0.3	-	-	0	-	-

HCM Signalized Intersection Capacity Analysis

3: Hood River Bridge & SR-14

	→	↘	↙	←	↖	↗
Movement	EBT	EBR	WBL	WBT	NBL	NBR
Lane Configurations	↑	↗	↘	↑	↘	↗
Traffic Volume (vph)	150	195	605	395	640	280
Future Volume (vph)	150	195	605	395	640	280
Ideal Flow (vphpl)	1900	1900	1900	1900	1900	1900
Total Lost time (s)	5.0	5.0	4.0	5.0	5.0	5.0
Lane Util. Factor	1.00	1.00	1.00	1.00	1.00	1.00
Frbp, ped/bikes	1.00	1.00	1.00	1.00	1.00	1.00
Flpb, ped/bikes	1.00	1.00	1.00	1.00	1.00	1.00
Frt	1.00	0.85	1.00	1.00	1.00	0.85
Flt Protected	1.00	1.00	0.95	1.00	0.95	1.00
Satd. Flow (prot)	1545	1509	1770	1792	1787	1553
Flt Permitted	1.00	1.00	0.95	1.00	0.95	1.00
Satd. Flow (perm)	1545	1509	1770	1792	1787	1553
Peak-hour factor, PHF	0.84	0.84	0.97	0.97	0.89	0.89
Adj. Flow (vph)	179	232	624	407	719	315
RTOR Reduction (vph)	0	28	0	0	0	77
Lane Group Flow (vph)	179	204	624	407	719	238
Confl. Peds. (#/hr)		1	1			1
Heavy Vehicles (%)	23%	7%	2%	6%	1%	4%
Turn Type	NA	pt+ov	Prot	NA	Prot	pt+ov
Protected Phases	2	2 8	1	6	8	8 1
Permitted Phases						
Actuated Green, G (s)	27.0	74.0	37.0	68.0	42.0	84.0
Effective Green, g (s)	27.0	74.0	37.0	68.0	42.0	84.0
Actuated g/C Ratio	0.22	0.62	0.31	0.57	0.35	0.70
Clearance Time (s)	5.0		4.0	5.0	5.0	
Vehicle Extension (s)	3.0		3.0	3.0	3.0	
Lane Grp Cap (vph)	347	930	545	1015	625	1087
v/s Ratio Prot	c0.12	0.14	c0.35	0.23	c0.40	0.15
v/s Ratio Perm						
v/c Ratio	0.52	0.22	1.14	0.40	1.15	0.22
Uniform Delay, d1	40.8	10.2	41.5	14.6	39.0	6.4
Progression Factor	1.00	1.00	1.00	1.00	1.00	1.00
Incremental Delay, d2	5.4	0.1	85.2	0.3	85.2	0.1
Delay (s)	46.2	10.3	126.7	14.8	124.2	6.5
Level of Service	D	B	F	B	F	A
Approach Delay (s)	25.9			82.5	88.3	
Approach LOS	C			F	F	
Intersection Summary						
HCM 2000 Control Delay			75.6		HCM 2000 Level of Service	E
HCM 2000 Volume to Capacity ratio			0.99			
Actuated Cycle Length (s)			120.0		Sum of lost time (s)	14.0
Intersection Capacity Utilization			102.3%		ICU Level of Service	G
Analysis Period (min)			15			

c Critical Lane Group

Queues

3: Hood River Bridge & SR-14

	→	↘	↙	←	↖	↗
Lane Group	EBT	EBR	WBL	WBT	NBL	NBR
Lane Group Flow (vph)	179	232	624	407	719	315
v/c Ratio	0.52	0.24	1.14	0.40	1.15	0.27
Control Delay	46.9	7.6	123.6	16.1	121.5	2.0
Queue Delay	0.0	0.0	0.0	0.0	0.0	0.0
Total Delay	46.9	7.6	123.6	16.1	121.5	2.0
Queue Length 50th (ft)	122	49	~566	168	~655	13
Queue Length 95th (ft)	182	79	#792	241	#874	40
Internal Link Dist (ft)	1219			2070	431	
Turn Bay Length (ft)		250	125			125
Base Capacity (vph)	347	958	545	1015	625	1153
Starvation Cap Reductn	0	0	0	0	0	0
Spillback Cap Reductn	0	0	0	0	0	0
Storage Cap Reductn	0	0	0	0	0	0
Reduced v/c Ratio	0.52	0.24	1.14	0.40	1.15	0.27

Intersection Summary

- ~ Volume exceeds capacity, queue is theoretically infinite.
Queue shown is maximum after two cycles.
- # 95th percentile volume exceeds capacity, queue may be longer.
Queue shown is maximum after two cycles.

HCM 2010 TWSC
4: Walnut St & SR-14

Intersection												
Int Delay, s/veh	14.3											

Movement	EBL	EBT	EBR	WBL	WBT	WBR	NBL	NBT	NBR	SBL	SBT	SBR
Traffic Vol, veh/h	10	470	10	15	895	25	35	5	40	5	5	20
Future Vol, veh/h	10	470	10	15	895	25	35	5	40	5	5	20
Conflicting Peds, #/hr	13	0	12	12	0	13	6	0	11	11	0	6
Sign Control	Free	Free	Free	Free	Free	Free	Stop	Stop	Stop	Stop	Stop	Stop
RT Channelized	-	-	None	-	-	None	-	-	None	-	-	None
Storage Length	-	-	-	-	-	-	-	-	-	-	-	-
Veh in Median Storage, #	-	0	-	-	0	-	-	0	-	-	0	-
Grade, %	-	0	-	-	0	-	-	0	-	-	0	-
Peak Hour Factor	81	81	81	92	92	92	65	65	65	73	73	73
Heavy Vehicles, %	0	8	8	5	4	4	2	0	0	0	0	3
Mvmt Flow	12	580	12	16	973	27	54	8	62	7	7	27

Major/Minor	Major1			Major2			Minor1			Minor2		
Conflicting Flow All	1011	0	0	604	0	0	1669	1666	610	1687	1658	1010
Stage 1	-	-	-	-	-	-	622	622	-	1030	1030	-
Stage 2	-	-	-	-	-	-	1047	1044	-	657	628	-
Critical Hdwy	4.1	-	-	4.15	-	-	7.12	6.5	6.2	7.1	6.5	6.23
Critical Hdwy Stg 1	-	-	-	-	-	-	6.12	5.5	-	6.1	5.5	-
Critical Hdwy Stg 2	-	-	-	-	-	-	6.12	5.5	-	6.1	5.5	-
Follow-up Hdwy	2.2	-	-	2.245	-	-	3.518	4	3.3	3.5	4	3.327
Pot Cap-1 Maneuver	694	-	-	959	-	-	76	98	498	75	99	290
Stage 1	-	-	-	-	-	-	474	482	-	284	313	-
Stage 2	-	-	-	-	-	-	276	309	-	457	479	-
Platoon blocked, %	-	-	-	-	-	-	-	-	-	-	-	-
Mov Cap-1 Maneuver	685	-	-	947	-	-	60	90	487	57	91	283
Mov Cap-2 Maneuver	-	-	-	-	-	-	60	90	-	57	91	-
Stage 1	-	-	-	-	-	-	457	465	-	274	298	-
Stage 2	-	-	-	-	-	-	231	294	-	378	462	-

Approach	EB	WB	NB	SB
HCM Control Delay, s	0.2	0.1	191.5	40.7
HCM LOS			F	E

Minor Lane/Major Mvmt	NBLn1	EBL	EBT	EBR	WBL	WBT	WBR	SBLn1
Capacity (veh/h)	111	685	-	-	947	-	-	141
HCM Lane V/C Ratio	1.109	0.018	-	-	0.017	-	-	0.291
HCM Control Delay (s)	191.5	10.4	0	-	8.9	0	-	40.7
HCM Lane LOS	F	B	A	-	A	A	-	E
HCM 95th %tile Q(veh)	7.6	0.1	-	-	0.1	-	-	1.1

HCM 2010 TWSC
5: Ash St & SR-14

Intersection												
Int Delay, s/veh	3.9											

Movement	EBL	EBT	EBR	WBL	WBT	WBR	NBL	NBT	NBR	SBL	SBT	SBR
Traffic Vol, veh/h	25	485	10	5	850	10	0	0	0	20	0	80
Future Vol, veh/h	25	485	10	5	850	10	0	0	0	20	0	80
Conflicting Peds, #/hr	3	0	9	9	0	3	8	0	8	8	0	8
Sign Control	Free	Free	Free	Free	Free	Free	Stop	Stop	Stop	Stop	Stop	Stop
RT Channelized	-	-	None	-	-	None	-	-	None	-	-	None
Storage Length	-	-	-	-	-	-	-	-	-	-	-	-
Veh in Median Storage, #	-	0	-	-	0	-	-	0	-	-	0	-
Grade, %	-	0	-	-	0	-	-	0	-	-	0	-
Peak Hour Factor	90	90	90	88	88	88	92	92	92	73	73	73
Heavy Vehicles, %	7	6	0	0	5	0	2	2	2	8	0	0
Mvmt Flow	28	539	11	6	966	11	0	0	0	27	0	110



















Major/Minor	Major1			Major2			Minor2		
Conflicting Flow All	985	0	0	550	0	0	1591	1597	989
Stage 1	-	-	-	-	-	-	991	991	-
Stage 2	-	-	-	-	-	-	600	606	-
Critical Hdwy	4.17	-	-	4.1	-	-	6.48	6.5	6.2
Critical Hdwy Stg 1	-	-	-	-	-	-	5.48	5.5	-
Critical Hdwy Stg 2	-	-	-	-	-	-	5.48	5.5	-
Follow-up Hdwy	2.263	-	-	2.2	-	-	3.572	4	3.3
Pot Cap-1 Maneuver	682	-	-	1030	-	-	114	108	302
Stage 1	-	-	-	-	-	-	350	327	-
Stage 2	-	-	-	-	-	-	537	490	-
Platoon blocked, %	-	-	-	-	-	-	-	-	-
Mov Cap-1 Maneuver	676	-	-	1021	-	-	104	0	297
Mov Cap-2 Maneuver	-	-	-	-	-	-	104	0	-
Stage 1	-	-	-	-	-	-	343	0	-
Stage 2	-	-	-	-	-	-	501	0	-

Approach	EB	WB	SB
HCM Control Delay, s	0.5	0	46.3
HCM LOS			E

Minor Lane/Major Mvmt	EBL	EBT	EBR	WBL	WBT	WBR	SBLn1
Capacity (veh/h)	676	-	-	1021	-	-	217
HCM Lane V/C Ratio	0.041	-	-	0.006	-	-	0.631
HCM Control Delay (s)	10.6	0	-	8.5	0	-	46.3
HCM Lane LOS	B	A	-	A	A	-	E
HCM 95th %tile Q(veh)	0.1	-	-	0	-	-	3.7







HCM Signalized Intersection Capacity Analysis

6: Oak St & SR-14

													
Movement	EBL	EBT	EBR	WBL	WBT	WBR	NBL	NBT	NBR	SBL	SBT	SBR	
Lane Configurations													
Traffic Volume (vph)	210	290	10	10	480	245	20	20	20	100	0	355	
Future Volume (vph)	210	290	10	10	480	245	20	20	20	100	0	355	
Ideal Flow (vphpl)	1900	1900	1900	1900	1900	1900	1900	1900	1900	1900	1900	1900	
Total Lost time (s)	4.5	4.5			4.5			4.5			4.5	4.5	
Lane Util. Factor	1.00	1.00			1.00			1.00			1.00	1.00	
Frbp, ped/bikes	1.00	1.00			0.99			0.99			1.00	0.98	
Flpb, ped/bikes	1.00	1.00			1.00			1.00			1.00	1.00	
Frt	1.00	0.99			0.95			0.95			1.00	0.85	
Flt Protected	0.95	1.00			1.00			0.98			0.95	1.00	
Satd. Flow (prot)	1752	1666			1702			1674			1715	1559	
Flt Permitted	0.95	1.00			0.99			0.88			0.75	1.00	
Satd. Flow (perm)	1752	1666			1694			1491			1355	1559	
Peak-hour factor, PHF	0.79	0.79	0.79	0.90	0.90	0.90	0.83	0.83	0.83	0.81	0.81	0.81	
Adj. Flow (vph)	266	367	13	11	533	272	24	24	24	123	0	438	
RTOR Reduction (vph)	0	1	0	0	17	0	0	19	0	0	0	369	
Lane Group Flow (vph)	266	379	0	0	799	0	0	53	0	0	123	69	
Confl. Peds. (#/hr)	6		7	7		6	2		1	1		2	
Confl. Bikes (#/hr)						1							
Heavy Vehicles (%)	3%	12%	50%	0%	7%	2%	13%	4%	0%	5%	0%	1%	
Turn Type	Prot	NA		Perm	NA		Perm	NA		Perm	NA	Perm	
Protected Phases	7	4			8			2			6		
Permitted Phases				8			2			6		6	
Actuated Green, G (s)	16.2	67.6			46.9			14.3			14.3	14.3	
Effective Green, g (s)	16.2	67.6			46.9			14.3			14.3	14.3	
Actuated g/C Ratio	0.18	0.74			0.52			0.16			0.16	0.16	
Clearance Time (s)	4.5	4.5			4.5			4.5			4.5	4.5	
Vehicle Extension (s)	3.0	3.0			3.0			3.0			3.0	3.0	
Lane Grp Cap (vph)	312	1238			874			234			213	245	
v/s Ratio Prot	c0.15	0.23											
v/s Ratio Perm					c0.47			0.04			c0.09	0.04	
v/c Ratio	0.85	0.31			0.91			0.22			0.58	0.28	
Uniform Delay, d1	36.2	3.9			20.1			33.5			35.5	33.8	
Progression Factor	1.00	1.00			1.00			1.00			1.00	1.00	
Incremental Delay, d2	19.6	0.1			13.8			0.5			3.8	0.6	
Delay (s)	55.8	4.0			33.9			33.9			39.3	34.4	
Level of Service	E	A			C			C			D	C	
Approach Delay (s)		25.3			33.9			33.9			35.5		
Approach LOS		C			C			C			D		
Intersection Summary													
HCM 2000 Control Delay			31.7									HCM 2000 Level of Service	C
HCM 2000 Volume to Capacity ratio			0.84										
Actuated Cycle Length (s)			90.9									Sum of lost time (s)	13.5
Intersection Capacity Utilization			80.5%									ICU Level of Service	D
Analysis Period (min)			15										
c Critical Lane Group													

Queues

6: Oak St & SR-14

						
Lane Group	EBL	EBT	WBT	NBT	SBT	SBR
Lane Group Flow (vph)	266	380	816	72	123	438
v/c Ratio	0.85	0.31	0.92	0.28	0.58	0.71
Control Delay	64.3	5.1	37.8	28.2	47.7	10.8
Queue Delay	0.0	0.0	0.0	0.0	0.0	0.0
Total Delay	64.3	5.1	37.8	28.2	47.7	10.8
Queue Length 50th (ft)	156	60	403	26	69	0
Queue Length 95th (ft)	#254	98	#733	58	112	45
Internal Link Dist (ft)		229	268	100	659	
Turn Bay Length (ft)	100					75
Base Capacity (vph)	321	1309	949	350	302	687
Starvation Cap Reductn	0	0	0	0	0	0
Spillback Cap Reductn	0	0	0	0	0	0
Storage Cap Reductn	0	0	0	0	0	0
Reduced v/c Ratio	0.83	0.29	0.86	0.21	0.41	0.64

Intersection Summary

95th percentile volume exceeds capacity, queue may be longer.
Queue shown is maximum after two cycles.

HCM 2010 TWSC
7: Maple St & SR-14

Intersection												
Int Delay, s/veh	7.6											

Movement	EBL	EBT	EBR	WBL	WBT	WBR	NBL	NBT	NBR	SBL	SBT	SBR
Traffic Vol, veh/h	10	385	20	5	625	5	95	5	25	5	5	10
Future Vol, veh/h	10	385	20	5	625	5	95	5	25	5	5	10
Conflicting Peds, #/hr	4	0	2	2	0	4	1	0	1	1	0	1
Sign Control	Free	Free	Free	Free	Free	Free	Stop	Stop	Stop	Stop	Stop	Stop
RT Channelized	-	-	None	-	-	None	-	-	None	-	-	None
Storage Length	-	-	80	-	-	-	-	-	0	-	-	-
Veh in Median Storage, #	-	0	-	-	0	-	-	0	-	-	0	-
Grade, %	-	0	-	-	0	-	-	0	-	-	0	-
Peak Hour Factor	92	92	92	87	87	87	86	86	86	74	74	74
Heavy Vehicles, %	0	9	7	22	7	0	2	0	6	0	0	3
Mvmt Flow	11	418	22	6	718	6	110	6	29	7	7	14

Major/Minor	Major1			Major2			Minor1			Minor2		
Conflicting Flow All	725	0	0	419	0	0	1185	1178	423	1178	1175	726
Stage 1	-	-	-	-	-	-	441	441	-	734	734	-
Stage 2	-	-	-	-	-	-	744	737	-	444	441	-
Critical Hdwy	4.1	-	-	4.32	-	-	7.12	6.5	6.26	7.1	6.5	6.23
Critical Hdwy Stg 1	-	-	-	-	-	-	6.12	5.5	-	6.1	5.5	-
Critical Hdwy Stg 2	-	-	-	-	-	-	6.12	5.5	-	6.1	5.5	-
Follow-up Hdwy	2.2	-	-	2.398	-	-	3.518	4	3.354	3.5	4	3.327
Pot Cap-1 Maneuver	887	-	-	1041	-	-	166	192	622	169	193	423
Stage 1	-	-	-	-	-	-	595	580	-	415	429	-
Stage 2	-	-	-	-	-	-	407	428	-	597	580	-
Platoon blocked, %	-	-	-	-	-	-	-	-	-	-	-	-
Mov Cap-1 Maneuver	884	-	-	1037	-	-	152	186	619	153	187	421
Mov Cap-2 Maneuver	-	-	-	-	-	-	152	186	-	153	187	-
Stage 1	-	-	-	-	-	-	584	570	-	408	424	-
Stage 2	-	-	-	-	-	-	382	423	-	551	570	-

Approach	EB	WB	NB	SB
HCM Control Delay, s	0.2	0.1	65.6	21.9
HCM LOS			F	C

Minor Lane/Major Mvmt	NBLn1	NBLn2	EBL	EBT	EBR	WBL	WBT	WBR	SBLn1
Capacity (veh/h)	153	619	884	-	-	1037	-	-	240
HCM Lane V/C Ratio	0.76	0.047	0.012	-	-	0.006	-	-	0.113
HCM Control Delay (s)	79.2	11.1	9.1	0	-	8.5	0	-	21.9
HCM Lane LOS	F	B	A	A	-	A	A	-	C
HCM 95th %tile Q(veh)	4.7	0.1	0	-	-	0	-	-	0.4

HCM 2010 Roundabout
28: SR-14

Intersection				
Intersection Delay, s/veh	10.7			
Intersection LOS	B			
Approach	EB	WB	NB	SB
Entry Lanes	1	1	1	1
Conflicting Circle Lanes	1	1	1	1
Adj Approach Flow, veh/h	456	434	321	54
Demand Flow Rate, veh/h	496	465	330	55
Vehicles Circulating, veh/h	38	255	466	710
Vehicles Exiting, veh/h	727	541	68	10
Follow-Up Headway, s	3.186	3.186	3.186	3.186
Ped Vol Crossing Leg, #/h	0	0	0	0
Ped Cap Adj	1.000	1.000	1.000	1.000
Approach Delay, s/veh	8.9	11.9	12.0	7.8
Approach LOS	A	B	B	A
Lane	Left	Left	Left	Left
Designated Moves	LTR	LTR	LTR	LTR
Assumed Moves	LTR	LTR	LTR	LTR
RT Channelized				
Lane Util	1.000	1.000	1.000	1.000
Critical Headway, s	5.193	5.193	5.193	5.193
Entry Flow, veh/h	496	465	330	55
Cap Entry Lane, veh/h	1088	876	709	556
Entry HV Adj Factor	0.919	0.934	0.973	0.982
Flow Entry, veh/h	456	434	321	54
Cap Entry, veh/h	1000	818	690	545
V/C Ratio	0.456	0.531	0.465	0.099
Control Delay, s/veh	8.9	11.9	12.0	7.8
LOS	A	B	B	A
95th %tile Queue, veh	2	3	2	0

HCM 2010 TWSC
1: SR-14 & SR-141

Intersection

Int Delay, s/veh 7.1

Movement	EBL	EBT	WBT	WBR	SBL	SBR
Traffic Vol, veh/h	55	290	470	220	115	60
Future Vol, veh/h	55	290	470	220	115	60
Conflicting Peds, #/hr	0	0	0	0	0	0
Sign Control	Free	Free	Free	Free	Stop	Stop
RT Channelized	-	None	-	Free	-	None
Storage Length	-	-	-	-	0	-
Veh in Median Storage, #	-	0	0	-	0	-
Grade, %	-	0	0	-	0	-
Peak Hour Factor	86	86	87	87	88	88
Heavy Vehicles, %	4	11	5	2	6	7
Mvmt Flow	64	337	540	253	131	68

Major/Minor	Major1	Major2	Minor2
Conflicting Flow All	540	0	540
Stage 1	-	-	540
Stage 2	-	-	465
Critical Hdwy	4.14	-	6.27
Critical Hdwy Stg 1	-	-	5.46
Critical Hdwy Stg 2	-	-	5.46
Follow-up Hdwy	2.236	-	3.363
Pot Cap-1 Maneuver	1018	-	532
Stage 1	-	-	576
Stage 2	-	-	624
Platoon blocked, %	-	-	-
Mov Cap-1 Maneuver	1018	-	532
Mov Cap-2 Maneuver	-	-	-
Stage 1	-	-	576
Stage 2	-	-	576

Approach	EB	WB	SB
HCM Control Delay, s	1.4	0	38
HCM LOS			E

Minor Lane/Major Mvmt	EBL	EBT	WBT	SBLn1
Capacity (veh/h)	1018	-	-	299
HCM Lane V/C Ratio	0.063	-	-	0.665
HCM Control Delay (s)	8.8	0	-	38
HCM Lane LOS	A	A	-	E
HCM 95th %tile Q(veh)	0.2	-	-	4.4

HCM 2010 TWSC
 2: SR-14 & Dock Grade Rd

Intersection												
Int Delay, s/veh	1.1											

Movement	EBL	EBT	EBR	WBL	WBT	WBR	NBL	NBT	NBR	SBL	SBT	SBR
Traffic Vol, veh/h	60	340	5	10	675	350	15	5	5	0	0	0
Future Vol, veh/h	60	340	5	10	675	350	15	5	5	0	0	0
Conflicting Peds, #/hr	0	0	0	0	0	0	0	0	0	0	0	0
Sign Control	Free	Free	Free	Free	Free	Free	Stop	Stop	Stop	Stop	Stop	Stop
RT Channelized	-	-	None	-	-	None	-	-	None	-	-	None
Storage Length	125	-	-	125	-	325	-	-	-	-	-	-
Veh in Median Storage, #	-	0	-	-	0	-	-	0	-	-	0	-
Grade, %	-	0	-	-	0	-	-	0	-	-	0	-
Peak Hour Factor	86	86	86	91	91	91	67	67	67	92	92	92
Heavy Vehicles, %	1	14	8	0	21	5	0	0	0	2	2	2
Mvmt Flow	70	395	6	11	742	385	22	7	7	0	0	0

Major/Minor	Major1			Major2			Minor1		
Conflicting Flow All	742	0	0	401	0	0	1302	1302	398
Stage 1	-	-	-	-	-	-	538	538	-
Stage 2	-	-	-	-	-	-	764	764	-
Critical Hdwy	4.11	-	-	4.1	-	-	6.4	6.5	6.2
Critical Hdwy Stg 1	-	-	-	-	-	-	5.4	5.5	-
Critical Hdwy Stg 2	-	-	-	-	-	-	5.4	5.5	-
Follow-up Hdwy	2.209	-	-	2.2	-	-	3.5	4	3.3
Pot Cap-1 Maneuver	870	-	-	1169	-	-	179	162	656
Stage 1	-	-	-	-	-	-	589	526	-
Stage 2	-	-	-	-	-	-	463	416	-
Platoon blocked, %	-	-	-	-	-	-	-	-	-
Mov Cap-1 Maneuver	870	-	-	1169	-	-	163	0	656
Mov Cap-2 Maneuver	-	-	-	-	-	-	163	0	-
Stage 1	-	-	-	-	-	-	542	0	-
Stage 2	-	-	-	-	-	-	459	0	-

Approach	EB	WB	NB
HCM Control Delay, s	1.4	0.1	26.9
HCM LOS			D

Minor Lane/Major Mvmt	NBLn1	EBL	EBT	EBR	WBL	WBT	WBR
Capacity (veh/h)	201	870	-	-	1169	-	-
HCM Lane V/C Ratio	0.186	0.08	-	-	0.009	-	-
HCM Control Delay (s)	26.9	9.5	-	-	8.1	-	-
HCM Lane LOS	D	A	-	-	A	-	-
HCM 95th %tile Q(veh)	0.7	0.3	-	-	0	-	-

HCM Signalized Intersection Capacity Analysis

3: Hood River Bridge & SR-14

	→	↘	↙	←	↖	↗
Movement	EBT	EBR	WBL	WBT	NBL	NBR
Lane Configurations	↑	↗	↘	↑	↘	↗
Traffic Volume (vph)	150	195	605	395	640	280
Future Volume (vph)	150	195	605	395	640	280
Ideal Flow (vphpl)	1900	1900	1900	1900	1900	1900
Total Lost time (s)	5.0	5.0	4.0	5.0	5.0	5.0
Lane Util. Factor	1.00	1.00	1.00	1.00	1.00	1.00
Frbp, ped/bikes	1.00	1.00	1.00	1.00	1.00	1.00
Flpb, ped/bikes	1.00	1.00	1.00	1.00	1.00	1.00
Frt	1.00	0.85	1.00	1.00	1.00	0.85
Flt Protected	1.00	1.00	0.95	1.00	0.95	1.00
Satd. Flow (prot)	1545	1509	1770	1792	1787	1553
Flt Permitted	1.00	1.00	0.95	1.00	0.95	1.00
Satd. Flow (perm)	1545	1509	1770	1792	1787	1553
Peak-hour factor, PHF	0.84	0.84	0.97	0.97	0.89	0.89
Adj. Flow (vph)	179	232	624	407	719	315
RTOR Reduction (vph)	0	28	0	0	0	77
Lane Group Flow (vph)	179	204	624	407	719	238
Confl. Peds. (#/hr)		1	1			1
Heavy Vehicles (%)	23%	7%	2%	6%	1%	4%
Turn Type	NA	pt+ov	Prot	NA	Prot	pt+ov
Protected Phases	2	2 8	1	6	8	8 1
Permitted Phases						
Actuated Green, G (s)	27.0	74.0	37.0	68.0	42.0	84.0
Effective Green, g (s)	27.0	74.0	37.0	68.0	42.0	84.0
Actuated g/C Ratio	0.22	0.62	0.31	0.57	0.35	0.70
Clearance Time (s)	5.0		4.0	5.0	5.0	
Vehicle Extension (s)	3.0		3.0	3.0	3.0	
Lane Grp Cap (vph)	347	930	545	1015	625	1087
v/s Ratio Prot	c0.12	0.14	c0.35	0.23	c0.40	0.15
v/s Ratio Perm						
v/c Ratio	0.52	0.22	1.14	0.40	1.15	0.22
Uniform Delay, d1	40.8	10.2	41.5	14.6	39.0	6.4
Progression Factor	1.00	1.00	1.00	1.00	1.00	1.00
Incremental Delay, d2	5.4	0.1	85.2	0.3	85.2	0.1
Delay (s)	46.2	10.3	126.7	14.8	124.2	6.5
Level of Service	D	B	F	B	F	A
Approach Delay (s)	25.9			82.5	88.3	
Approach LOS	C			F	F	
Intersection Summary						
HCM 2000 Control Delay			75.6		HCM 2000 Level of Service	E
HCM 2000 Volume to Capacity ratio			0.99			
Actuated Cycle Length (s)			120.0		Sum of lost time (s)	14.0
Intersection Capacity Utilization			102.3%		ICU Level of Service	G
Analysis Period (min)			15			

c Critical Lane Group

Queues

3: Hood River Bridge & SR-14

	→	↘	↙	←	↖	↗
Lane Group	EBT	EBR	WBL	WBT	NBL	NBR
Lane Group Flow (vph)	179	232	624	407	719	315
v/c Ratio	0.52	0.24	1.14	0.40	1.15	0.27
Control Delay	46.9	7.6	123.6	16.1	121.5	2.0
Queue Delay	0.0	0.0	0.0	0.0	0.0	0.0
Total Delay	46.9	7.6	123.6	16.1	121.5	2.0
Queue Length 50th (ft)	122	49	~566	168	~655	13
Queue Length 95th (ft)	182	79	#792	241	#874	40
Internal Link Dist (ft)	1219			2070	431	
Turn Bay Length (ft)		250	125			125
Base Capacity (vph)	347	958	545	1015	625	1153
Starvation Cap Reductn	0	0	0	0	0	0
Spillback Cap Reductn	0	0	0	0	0	0
Storage Cap Reductn	0	0	0	0	0	0
Reduced v/c Ratio	0.52	0.24	1.14	0.40	1.15	0.27

Intersection Summary

- ~ Volume exceeds capacity, queue is theoretically infinite.
Queue shown is maximum after two cycles.
- # 95th percentile volume exceeds capacity, queue may be longer.
Queue shown is maximum after two cycles.

HCM 2010 TWSC
4: Walnut St & SR-14

Intersection												
Int Delay, s/veh	14.3											

Movement	EBL	EBT	EBR	WBL	WBT	WBR	NBL	NBT	NBR	SBL	SBT	SBR
Traffic Vol, veh/h	10	470	10	15	895	25	35	5	40	5	5	20
Future Vol, veh/h	10	470	10	15	895	25	35	5	40	5	5	20
Conflicting Peds, #/hr	13	0	12	12	0	13	6	0	11	11	0	6
Sign Control	Free	Free	Free	Free	Free	Free	Stop	Stop	Stop	Stop	Stop	Stop
RT Channelized	-	-	None	-	-	None	-	-	None	-	-	None
Storage Length	-	-	-	-	-	-	-	-	-	-	-	-
Veh in Median Storage, #	-	0	-	-	0	-	-	0	-	-	0	-
Grade, %	-	0	-	-	0	-	-	0	-	-	0	-
Peak Hour Factor	81	81	81	92	92	92	65	65	65	73	73	73
Heavy Vehicles, %	0	8	8	5	4	4	2	0	0	0	0	3
Mvmt Flow	12	580	12	16	973	27	54	8	62	7	7	27

Major/Minor	Major1			Major2			Minor1			Minor2		
Conflicting Flow All	1011	0	0	604	0	0	1669	1666	610	1687	1658	1010
Stage 1	-	-	-	-	-	-	622	622	-	1030	1030	-
Stage 2	-	-	-	-	-	-	1047	1044	-	657	628	-
Critical Hdwy	4.1	-	-	4.15	-	-	7.12	6.5	6.2	7.1	6.5	6.23
Critical Hdwy Stg 1	-	-	-	-	-	-	6.12	5.5	-	6.1	5.5	-
Critical Hdwy Stg 2	-	-	-	-	-	-	6.12	5.5	-	6.1	5.5	-
Follow-up Hdwy	2.2	-	-	2.245	-	-	3.518	4	3.3	3.5	4	3.327
Pot Cap-1 Maneuver	694	-	-	959	-	-	76	98	498	75	99	290
Stage 1	-	-	-	-	-	-	474	482	-	284	313	-
Stage 2	-	-	-	-	-	-	276	309	-	457	479	-
Platoon blocked, %	-	-	-	-	-	-	-	-	-	-	-	-
Mov Cap-1 Maneuver	685	-	-	947	-	-	60	90	487	57	91	283
Mov Cap-2 Maneuver	-	-	-	-	-	-	60	90	-	57	91	-
Stage 1	-	-	-	-	-	-	457	465	-	274	298	-
Stage 2	-	-	-	-	-	-	231	294	-	378	462	-

Approach	EB	WB	NB	SB
HCM Control Delay, s	0.2	0.1	191.5	40.7
HCM LOS			F	E

Minor Lane/Major Mvmt	NBLn1	EBL	EBT	EBR	WBL	WBT	WBR	SBLn1
Capacity (veh/h)	111	685	-	-	947	-	-	141
HCM Lane V/C Ratio	1.109	0.018	-	-	0.017	-	-	0.291
HCM Control Delay (s)	191.5	10.4	0	-	8.9	0	-	40.7
HCM Lane LOS	F	B	A	-	A	A	-	E
HCM 95th %tile Q(veh)	7.6	0.1	-	-	0.1	-	-	1.1

HCM 2010 TWSC
5: Ash St & SR-14

Intersection												
Int Delay, s/veh	3.9											

Movement	EBL	EBT	EBR	WBL	WBT	WBR	NBL	NBT	NBR	SBL	SBT	SBR
Traffic Vol, veh/h	25	485	10	5	850	10	0	0	0	20	0	80
Future Vol, veh/h	25	485	10	5	850	10	0	0	0	20	0	80
Conflicting Peds, #/hr	3	0	9	9	0	3	8	0	8	8	0	8
Sign Control	Free	Free	Free	Free	Free	Free	Stop	Stop	Stop	Stop	Stop	Stop
RT Channelized	-	-	None	-	-	None	-	-	None	-	-	None
Storage Length	-	-	-	-	-	-	-	-	-	-	-	-
Veh in Median Storage, #	-	0	-	-	0	-	-	0	-	-	0	-
Grade, %	-	0	-	-	0	-	-	0	-	-	0	-
Peak Hour Factor	90	90	90	88	88	88	92	92	92	73	73	73
Heavy Vehicles, %	7	6	0	0	5	0	2	2	2	8	0	0
Mvmt Flow	28	539	11	6	966	11	0	0	0	27	0	110



















Major/Minor	Major1			Major2			Minor2		
Conflicting Flow All	985	0	0	550	0	0	1591	1597	989
Stage 1	-	-	-	-	-	-	991	991	-
Stage 2	-	-	-	-	-	-	600	606	-
Critical Hdwy	4.17	-	-	4.1	-	-	6.48	6.5	6.2
Critical Hdwy Stg 1	-	-	-	-	-	-	5.48	5.5	-
Critical Hdwy Stg 2	-	-	-	-	-	-	5.48	5.5	-
Follow-up Hdwy	2.263	-	-	2.2	-	-	3.572	4	3.3
Pot Cap-1 Maneuver	682	-	-	1030	-	-	114	108	302
Stage 1	-	-	-	-	-	-	350	327	-
Stage 2	-	-	-	-	-	-	537	490	-
Platoon blocked, %	-	-	-	-	-	-	-	-	-
Mov Cap-1 Maneuver	676	-	-	1021	-	-	104	0	297
Mov Cap-2 Maneuver	-	-	-	-	-	-	104	0	-
Stage 1	-	-	-	-	-	-	343	0	-
Stage 2	-	-	-	-	-	-	501	0	-

Approach	EB	WB	SB
HCM Control Delay, s	0.5	0	46.3
HCM LOS			E

Minor Lane/Major Mvmt	EBL	EBT	EBR	WBL	WBT	WBR	SBLn1
Capacity (veh/h)	676	-	-	1021	-	-	217
HCM Lane V/C Ratio	0.041	-	-	0.006	-	-	0.631
HCM Control Delay (s)	10.6	0	-	8.5	0	-	46.3
HCM Lane LOS	B	A	-	A	A	-	E
HCM 95th %tile Q(veh)	0.1	-	-	0	-	-	3.7







HCM Signalized Intersection Capacity Analysis

6: Oak St & SR-14

													
Movement	EBL	EBT	EBR	WBL	WBT	WBR	NBL	NBT	NBR	SBL	SBT	SBR	
Lane Configurations													
Traffic Volume (vph)	210	290	10	10	480	245	20	20	20	100	0	355	
Future Volume (vph)	210	290	10	10	480	245	20	20	20	100	0	355	
Ideal Flow (vphpl)	1900	1900	1900	1900	1900	1900	1900	1900	1900	1900	1900	1900	
Total Lost time (s)	4.5	4.5			4.5			4.5			4.5	4.5	
Lane Util. Factor	1.00	1.00			1.00			1.00			1.00	1.00	
Frpb, ped/bikes	1.00	1.00			0.99			0.99			1.00	0.98	
Flpb, ped/bikes	1.00	1.00			1.00			1.00			1.00	1.00	
Frt	1.00	0.99			0.95			0.95			1.00	0.85	
Flt Protected	0.95	1.00			1.00			0.98			0.95	1.00	
Satd. Flow (prot)	1752	1666			1702			1674			1715	1559	
Flt Permitted	0.95	1.00			0.99			0.88			0.75	1.00	
Satd. Flow (perm)	1752	1666			1694			1491			1355	1559	
Peak-hour factor, PHF	0.79	0.79	0.79	0.90	0.90	0.90	0.83	0.83	0.83	0.81	0.81	0.81	
Adj. Flow (vph)	266	367	13	11	533	272	24	24	24	123	0	438	
RTOR Reduction (vph)	0	1	0	0	17	0	0	19	0	0	0	369	
Lane Group Flow (vph)	266	379	0	0	799	0	0	53	0	0	123	69	
Confl. Peds. (#/hr)	6		7	7		6	2		1	1		2	
Confl. Bikes (#/hr)						1							
Heavy Vehicles (%)	3%	12%	50%	0%	7%	2%	13%	4%	0%	5%	0%	1%	
Turn Type	Prot	NA		Perm	NA		Perm	NA		Perm	NA	Perm	
Protected Phases	7	4			8			2			6		
Permitted Phases				8			2			6		6	
Actuated Green, G (s)	16.2	67.6			46.9			14.3			14.3	14.3	
Effective Green, g (s)	16.2	67.6			46.9			14.3			14.3	14.3	
Actuated g/C Ratio	0.18	0.74			0.52			0.16			0.16	0.16	
Clearance Time (s)	4.5	4.5			4.5			4.5			4.5	4.5	
Vehicle Extension (s)	3.0	3.0			3.0			3.0			3.0	3.0	
Lane Grp Cap (vph)	312	1238			874			234			213	245	
v/s Ratio Prot	c0.15	0.23											
v/s Ratio Perm					c0.47			0.04			c0.09	0.04	
v/c Ratio	0.85	0.31			0.91			0.22			0.58	0.28	
Uniform Delay, d1	36.2	3.9			20.1			33.5			35.5	33.8	
Progression Factor	1.00	1.00			1.00			1.00			1.00	1.00	
Incremental Delay, d2	19.6	0.1			13.8			0.5			3.8	0.6	
Delay (s)	55.8	4.0			33.9			33.9			39.3	34.4	
Level of Service	E	A			C			C			D	C	
Approach Delay (s)		25.3			33.9			33.9			35.5		
Approach LOS		C			C			C			D		
Intersection Summary													
HCM 2000 Control Delay			31.7									HCM 2000 Level of Service	C
HCM 2000 Volume to Capacity ratio			0.84										
Actuated Cycle Length (s)			90.9									Sum of lost time (s)	13.5
Intersection Capacity Utilization			80.5%									ICU Level of Service	D
Analysis Period (min)			15										
c Critical Lane Group													

Queues

6: Oak St & SR-14

						
Lane Group	EBL	EBT	WBT	NBT	SBT	SBR
Lane Group Flow (vph)	266	380	816	72	123	438
v/c Ratio	0.85	0.31	0.92	0.28	0.58	0.71
Control Delay	64.3	5.1	37.8	28.2	47.7	10.8
Queue Delay	0.0	0.0	0.0	0.0	0.0	0.0
Total Delay	64.3	5.1	37.8	28.2	47.7	10.8
Queue Length 50th (ft)	156	60	403	26	69	0
Queue Length 95th (ft)	#254	98	#733	58	112	45
Internal Link Dist (ft)		229	268	100	659	
Turn Bay Length (ft)	100					75
Base Capacity (vph)	321	1309	949	350	302	687
Starvation Cap Reductn	0	0	0	0	0	0
Spillback Cap Reductn	0	0	0	0	0	0
Storage Cap Reductn	0	0	0	0	0	0
Reduced v/c Ratio	0.83	0.29	0.86	0.21	0.41	0.64

Intersection Summary

95th percentile volume exceeds capacity, queue may be longer.
Queue shown is maximum after two cycles.

HCM 2010 TWSC
7: Maple St & SR-14

Intersection												
Int Delay, s/veh	1.7											

Movement	EBL	EBT	EBR	WBL	WBT	WBR	NBL	NBT	NBR	SBL	SBT	SBR
Traffic Vol, veh/h	10	390	15	0	695	5	25	0	10	5	5	10
Future Vol, veh/h	10	390	15	0	695	5	25	0	10	5	5	10
Conflicting Peds, #/hr	4	0	2	2	0	4	1	0	1	1	0	1
Sign Control	Free	Free	Free	Free	Free	Free	Stop	Stop	Stop	Stop	Stop	Stop
RT Channelized	-	-	None	-	-	None	-	-	None	-	-	None
Storage Length	-	-	80	-	-	-	-	-	0	-	-	-
Veh in Median Storage, #	-	0	-	-	0	-	-	0	-	-	0	-
Grade, %	-	0	-	-	0	-	-	0	-	-	0	-
Peak Hour Factor	92	92	92	87	87	87	86	86	86	74	74	74
Heavy Vehicles, %	0	9	64	64	7	0	34	0	34	0	0	3
Mvmt Flow	11	424	16	0	799	6	29	0	12	7	7	14

Major/Minor	Major1			Major2			Minor1			Minor2		
Conflicting Flow All	806	0	0	425	0	0	1260	1253	429	1250	1250	807
Stage 1	-	-	-	-	-	-	447	447	-	803	803	-
Stage 2	-	-	-	-	-	-	813	806	-	447	447	-
Critical Hdwy	4.1	-	-	4.74	-	-	7.44	6.5	6.54	7.1	6.5	6.23
Critical Hdwy Stg 1	-	-	-	-	-	-	6.44	5.5	-	6.1	5.5	-
Critical Hdwy Stg 2	-	-	-	-	-	-	6.44	5.5	-	6.1	5.5	-
Follow-up Hdwy	2.2	-	-	2.776	-	-	3.806	4	3.606	3.5	4	3.327
Pot Cap-1 Maneuver	828	-	-	869	-	-	127	174	563	151	174	380
Stage 1	-	-	-	-	-	-	534	577	-	380	399	-
Stage 2	-	-	-	-	-	-	329	398	-	595	577	-
Platoon blocked, %	-	-	-	-	-	-	-	-	-	-	-	-
Mov Cap-1 Maneuver	825	-	-	866	-	-	117	171	560	145	171	378
Mov Cap-2 Maneuver	-	-	-	-	-	-	117	171	-	145	171	-
Stage 1	-	-	-	-	-	-	524	566	-	373	399	-
Stage 2	-	-	-	-	-	-	311	398	-	570	566	-

Approach	EB	WB	NB	SB
HCM Control Delay, s	0.2	0	36	23.5
HCM LOS			E	C

Minor Lane/Major Mvmt	NBLn1	NBLn2	EBL	EBT	EBR	WBL	WBT	WBR	SBLn1
Capacity (veh/h)	117	560	825	-	-	866	-	-	222
HCM Lane V/C Ratio	0.248	0.021	0.013	-	-	-	-	-	0.122
HCM Control Delay (s)	45.7	11.6	9.4	0	-	0	-	-	23.5
HCM Lane LOS	E	B	A	A	-	A	-	-	C
HCM 95th %tile Q(veh)	0.9	0.1	0	-	-	0	-	-	0.4

HCM 2010 Roundabout
28: SR-14

Intersection				
Intersection Delay, s/veh	12.3			
Intersection LOS	B			
Approach	EB	WB	NB	SB
Entry Lanes	1	1	1	1
Conflicting Circle Lanes	1	1	1	1
Adj Approach Flow, veh/h	440	440	424	54
Demand Flow Rate, veh/h	475	470	428	55
Vehicles Circulating, veh/h	43	335	442	789
Vehicles Exiting, veh/h	801	535	76	16
Follow-Up Headway, s	3.186	3.186	3.186	3.186
Ped Vol Crossing Leg, #/h	0	0	0	0
Ped Cap Adj	1.000	1.000	1.000	1.000
Approach Delay, s/veh	8.6	14.1	14.9	8.5
Approach LOS	A	B	B	A
Lane	Left	Left	Left	Left
Designated Moves	LTR	LTR	LTR	LTR
Assumed Moves	LTR	LTR	LTR	LTR
RT Channelized				
Lane Util	1.000	1.000	1.000	1.000
Critical Headway, s	5.193	5.193	5.193	5.193
Entry Flow, veh/h	475	470	428	55
Cap Entry Lane, veh/h	1082	808	726	513
Entry HV Adj Factor	0.926	0.937	0.991	0.982
Flow Entry, veh/h	440	440	424	54
Cap Entry, veh/h	1002	757	719	504
V/C Ratio	0.439	0.581	0.589	0.107
Control Delay, s/veh	8.6	14.1	14.9	8.5
LOS	A	B	B	A
95th %tile Queue, veh	2	4	4	0

HCM 2010 TWSC
1: SR-14 & SR-141

Intersection

Int Delay, s/veh 7.1

Movement	EBL	EBT	WBT	WBR	SBL	SBR
Traffic Vol, veh/h	55	290	470	220	115	60
Future Vol, veh/h	55	290	470	220	115	60
Conflicting Peds, #/hr	0	0	0	0	0	0
Sign Control	Free	Free	Free	Free	Stop	Stop
RT Channelized	-	None	-	Free	-	None
Storage Length	-	-	-	-	0	-
Veh in Median Storage, #	-	0	0	-	0	-
Grade, %	-	0	0	-	0	-
Peak Hour Factor	86	86	87	87	88	88
Heavy Vehicles, %	4	11	5	2	6	7
Mvmt Flow	64	337	540	253	131	68

Major/Minor	Major1	Major2	Minor2
Conflicting Flow All	540	0	540
Stage 1	-	-	540
Stage 2	-	-	465
Critical Hdwy	4.14	-	6.27
Critical Hdwy Stg 1	-	-	5.46
Critical Hdwy Stg 2	-	-	5.46
Follow-up Hdwy	2.236	-	3.363
Pot Cap-1 Maneuver	1018	-	532
Stage 1	-	-	576
Stage 2	-	-	624
Platoon blocked, %	-	-	-
Mov Cap-1 Maneuver	1018	-	532
Mov Cap-2 Maneuver	-	-	-
Stage 1	-	-	576
Stage 2	-	-	576

Approach	EB	WB	SB
HCM Control Delay, s	1.4	0	38
HCM LOS			E

Minor Lane/Major Mvmt	EBL	EBT	WBT	SBLn1
Capacity (veh/h)	1018	-	-	299
HCM Lane V/C Ratio	0.063	-	-	0.665
HCM Control Delay (s)	8.8	0	-	38
HCM Lane LOS	A	A	-	E
HCM 95th %tile Q(veh)	0.2	-	-	4.4

HCM 2010 TWSC
 2: SR-14 & Dock Grade Rd

Intersection												
Int Delay, s/veh	1.1											

Movement	EBL	EBT	EBR	WBL	WBT	WBR	NBL	NBT	NBR	SBL	SBT	SBR
Traffic Vol, veh/h	60	340	5	10	675	350	15	5	5	0	0	0
Future Vol, veh/h	60	340	5	10	675	350	15	5	5	0	0	0
Conflicting Peds, #/hr	0	0	0	0	0	0	0	0	0	0	0	0
Sign Control	Free	Free	Free	Free	Free	Free	Stop	Stop	Stop	Stop	Stop	Stop
RT Channelized	-	-	None	-	-	None	-	-	None	-	-	None
Storage Length	125	-	-	125	-	325	-	-	-	-	-	-
Veh in Median Storage, #	-	0	-	-	0	-	-	0	-	-	0	-
Grade, %	-	0	-	-	0	-	-	0	-	-	0	-
Peak Hour Factor	86	86	86	91	91	91	67	67	67	92	92	92
Heavy Vehicles, %	1	14	8	0	21	5	0	0	0	2	2	2
Mvmt Flow	70	395	6	11	742	385	22	7	7	0	0	0

Major/Minor	Major1			Major2			Minor1		
Conflicting Flow All	742	0	0	401	0	0	1302	1302	398
Stage 1	-	-	-	-	-	-	538	538	-
Stage 2	-	-	-	-	-	-	764	764	-
Critical Hdwy	4.11	-	-	4.1	-	-	6.4	6.5	6.2
Critical Hdwy Stg 1	-	-	-	-	-	-	5.4	5.5	-
Critical Hdwy Stg 2	-	-	-	-	-	-	5.4	5.5	-
Follow-up Hdwy	2.209	-	-	2.2	-	-	3.5	4	3.3
Pot Cap-1 Maneuver	870	-	-	1169	-	-	179	162	656
Stage 1	-	-	-	-	-	-	589	526	-
Stage 2	-	-	-	-	-	-	463	416	-
Platoon blocked, %	-	-	-	-	-	-	-	-	-
Mov Cap-1 Maneuver	870	-	-	1169	-	-	163	0	656
Mov Cap-2 Maneuver	-	-	-	-	-	-	163	0	-
Stage 1	-	-	-	-	-	-	542	0	-
Stage 2	-	-	-	-	-	-	459	0	-

Approach	EB	WB	NB
HCM Control Delay, s	1.4	0.1	26.9
HCM LOS			D

Minor Lane/Major Mvmt	NBLn1	EBL	EBT	EBR	WBL	WBT	WBR
Capacity (veh/h)	201	870	-	-	1169	-	-
HCM Lane V/C Ratio	0.186	0.08	-	-	0.009	-	-
HCM Control Delay (s)	26.9	9.5	-	-	8.1	-	-
HCM Lane LOS	D	A	-	-	A	-	-
HCM 95th %tile Q(veh)	0.7	0.3	-	-	0	-	-

HCM Signalized Intersection Capacity Analysis

3: Hood River Bridge & SR-14

	→	↘	↙	←	↖	↗
Movement	EBT	EBR	WBL	WBT	NBL	NBR
Lane Configurations	↑	↗	↘	↑	↘	↗
Traffic Volume (vph)	150	195	605	395	640	280
Future Volume (vph)	150	195	605	395	640	280
Ideal Flow (vphpl)	1900	1900	1900	1900	1900	1900
Total Lost time (s)	5.0	5.0	4.0	5.0	5.0	5.0
Lane Util. Factor	1.00	1.00	1.00	1.00	1.00	1.00
Frbp, ped/bikes	1.00	1.00	1.00	1.00	1.00	1.00
Flpb, ped/bikes	1.00	1.00	1.00	1.00	1.00	1.00
Frt	1.00	0.85	1.00	1.00	1.00	0.85
Flt Protected	1.00	1.00	0.95	1.00	0.95	1.00
Satd. Flow (prot)	1545	1509	1770	1792	1787	1553
Flt Permitted	1.00	1.00	0.95	1.00	0.95	1.00
Satd. Flow (perm)	1545	1509	1770	1792	1787	1553
Peak-hour factor, PHF	0.84	0.84	0.97	0.97	0.89	0.89
Adj. Flow (vph)	179	232	624	407	719	315
RTOR Reduction (vph)	0	28	0	0	0	77
Lane Group Flow (vph)	179	204	624	407	719	238
Confl. Peds. (#/hr)		1	1			1
Heavy Vehicles (%)	23%	7%	2%	6%	1%	4%
Turn Type	NA	pt+ov	Prot	NA	Prot	pt+ov
Protected Phases	2	2 8	1	6	8	8 1
Permitted Phases						
Actuated Green, G (s)	27.0	74.0	37.0	68.0	42.0	84.0
Effective Green, g (s)	27.0	74.0	37.0	68.0	42.0	84.0
Actuated g/C Ratio	0.22	0.62	0.31	0.57	0.35	0.70
Clearance Time (s)	5.0		4.0	5.0	5.0	
Vehicle Extension (s)	3.0		3.0	3.0	3.0	
Lane Grp Cap (vph)	347	930	545	1015	625	1087
v/s Ratio Prot	c0.12	0.14	c0.35	0.23	c0.40	0.15
v/s Ratio Perm						
v/c Ratio	0.52	0.22	1.14	0.40	1.15	0.22
Uniform Delay, d1	40.8	10.2	41.5	14.6	39.0	6.4
Progression Factor	1.00	1.00	1.00	1.00	1.00	1.00
Incremental Delay, d2	5.4	0.1	85.2	0.3	85.2	0.1
Delay (s)	46.2	10.3	126.7	14.8	124.2	6.5
Level of Service	D	B	F	B	F	A
Approach Delay (s)	25.9			82.5	88.3	
Approach LOS	C			F	F	
Intersection Summary						
HCM 2000 Control Delay			75.6		HCM 2000 Level of Service	E
HCM 2000 Volume to Capacity ratio			0.99			
Actuated Cycle Length (s)			120.0		Sum of lost time (s)	14.0
Intersection Capacity Utilization			102.3%		ICU Level of Service	G
Analysis Period (min)			15			

c Critical Lane Group

Queues

3: Hood River Bridge & SR-14

	→	↘	↙	←	↖	↗
Lane Group	EBT	EBR	WBL	WBT	NBL	NBR
Lane Group Flow (vph)	179	232	624	407	719	315
v/c Ratio	0.52	0.24	1.14	0.40	1.15	0.27
Control Delay	46.9	7.6	123.6	16.1	121.5	2.0
Queue Delay	0.0	0.0	0.0	0.0	0.0	0.0
Total Delay	46.9	7.6	123.6	16.1	121.5	2.0
Queue Length 50th (ft)	122	49	~566	168	~655	13
Queue Length 95th (ft)	182	79	#792	241	#874	40
Internal Link Dist (ft)	1219			2070	431	
Turn Bay Length (ft)		250	125			125
Base Capacity (vph)	347	958	545	1015	625	1153
Starvation Cap Reductn	0	0	0	0	0	0
Spillback Cap Reductn	0	0	0	0	0	0
Storage Cap Reductn	0	0	0	0	0	0
Reduced v/c Ratio	0.52	0.24	1.14	0.40	1.15	0.27

Intersection Summary

- ~ Volume exceeds capacity, queue is theoretically infinite.
Queue shown is maximum after two cycles.
- # 95th percentile volume exceeds capacity, queue may be longer.
Queue shown is maximum after two cycles.

HCM 2010 TWSC
4: Walnut St & SR-14

Intersection												
Int Delay, s/veh	14.3											

Movement	EBL	EBT	EBR	WBL	WBT	WBR	NBL	NBT	NBR	SBL	SBT	SBR
Traffic Vol, veh/h	10	470	10	15	895	25	35	5	40	5	5	20
Future Vol, veh/h	10	470	10	15	895	25	35	5	40	5	5	20
Conflicting Peds, #/hr	13	0	12	12	0	13	6	0	11	11	0	6
Sign Control	Free	Free	Free	Free	Free	Free	Stop	Stop	Stop	Stop	Stop	Stop
RT Channelized	-	-	None	-	-	None	-	-	None	-	-	None
Storage Length	-	-	-	-	-	-	-	-	-	-	-	-
Veh in Median Storage, #	-	0	-	-	0	-	-	0	-	-	0	-
Grade, %	-	0	-	-	0	-	-	0	-	-	0	-
Peak Hour Factor	81	81	81	92	92	92	65	65	65	73	73	73
Heavy Vehicles, %	0	8	8	5	4	4	2	0	0	0	0	3
Mvmt Flow	12	580	12	16	973	27	54	8	62	7	7	27

Major/Minor	Major1			Major2			Minor1			Minor2		
Conflicting Flow All	1011	0	0	604	0	0	1669	1666	610	1687	1658	1010
Stage 1	-	-	-	-	-	-	622	622	-	1030	1030	-
Stage 2	-	-	-	-	-	-	1047	1044	-	657	628	-
Critical Hdwy	4.1	-	-	4.15	-	-	7.12	6.5	6.2	7.1	6.5	6.23
Critical Hdwy Stg 1	-	-	-	-	-	-	6.12	5.5	-	6.1	5.5	-
Critical Hdwy Stg 2	-	-	-	-	-	-	6.12	5.5	-	6.1	5.5	-
Follow-up Hdwy	2.2	-	-	2.245	-	-	3.518	4	3.3	3.5	4	3.327
Pot Cap-1 Maneuver	694	-	-	959	-	-	76	98	498	75	99	290
Stage 1	-	-	-	-	-	-	474	482	-	284	313	-
Stage 2	-	-	-	-	-	-	276	309	-	457	479	-
Platoon blocked, %	-	-	-	-	-	-	-	-	-	-	-	-
Mov Cap-1 Maneuver	685	-	-	947	-	-	60	90	487	57	91	283
Mov Cap-2 Maneuver	-	-	-	-	-	-	60	90	-	57	91	-
Stage 1	-	-	-	-	-	-	457	465	-	274	298	-
Stage 2	-	-	-	-	-	-	231	294	-	378	462	-

Approach	EB	WB	NB	SB
HCM Control Delay, s	0.2	0.1	191.5	40.7
HCM LOS			F	E

Minor Lane/Major Mvmt	NBLn1	EBL	EBT	EBR	WBL	WBT	WBR	SBLn1
Capacity (veh/h)	111	685	-	-	947	-	-	141
HCM Lane V/C Ratio	1.109	0.018	-	-	0.017	-	-	0.291
HCM Control Delay (s)	191.5	10.4	0	-	8.9	0	-	40.7
HCM Lane LOS	F	B	A	-	A	A	-	E
HCM 95th %tile Q(veh)	7.6	0.1	-	-	0.1	-	-	1.1

HCM 2010 TWSC
5: Ash St & SR-14

Intersection												
Int Delay, s/veh	3.9											

Movement	EBL	EBT	EBR	WBL	WBT	WBR	NBL	NBT	NBR	SBL	SBT	SBR
Traffic Vol, veh/h	25	485	10	5	850	10	0	0	0	20	0	80
Future Vol, veh/h	25	485	10	5	850	10	0	0	0	20	0	80
Conflicting Peds, #/hr	3	0	9	9	0	3	8	0	8	8	0	8
Sign Control	Free	Free	Free	Free	Free	Free	Stop	Stop	Stop	Stop	Stop	Stop
RT Channelized	-	-	None	-	-	None	-	-	None	-	-	None
Storage Length	-	-	-	-	-	-	-	-	-	-	-	-
Veh in Median Storage, #	-	0	-	-	0	-	-	0	-	-	0	-
Grade, %	-	0	-	-	0	-	-	0	-	-	0	-
Peak Hour Factor	90	90	90	88	88	88	92	92	92	73	73	73
Heavy Vehicles, %	7	6	0	0	5	0	2	2	2	8	0	0
Mvmt Flow	28	539	11	6	966	11	0	0	0	27	0	110



















Major/Minor	Major1			Major2			Minor2		
Conflicting Flow All	985	0	0	550	0	0	1591	1597	989
Stage 1	-	-	-	-	-	-	991	991	-
Stage 2	-	-	-	-	-	-	600	606	-
Critical Hdwy	4.17	-	-	4.1	-	-	6.48	6.5	6.2
Critical Hdwy Stg 1	-	-	-	-	-	-	5.48	5.5	-
Critical Hdwy Stg 2	-	-	-	-	-	-	5.48	5.5	-
Follow-up Hdwy	2.263	-	-	2.2	-	-	3.572	4	3.3
Pot Cap-1 Maneuver	682	-	-	1030	-	-	114	108	302
Stage 1	-	-	-	-	-	-	350	327	-
Stage 2	-	-	-	-	-	-	537	490	-
Platoon blocked, %	-	-	-	-	-	-	-	-	-
Mov Cap-1 Maneuver	676	-	-	1021	-	-	104	0	297
Mov Cap-2 Maneuver	-	-	-	-	-	-	104	0	-
Stage 1	-	-	-	-	-	-	343	0	-
Stage 2	-	-	-	-	-	-	501	0	-

Approach	EB	WB	SB
HCM Control Delay, s	0.5	0	46.3
HCM LOS			E

Minor Lane/Major Mvmt	EBL	EBT	EBR	WBL	WBT	WBR	SBLn1
Capacity (veh/h)	676	-	-	1021	-	-	217
HCM Lane V/C Ratio	0.041	-	-	0.006	-	-	0.631
HCM Control Delay (s)	10.6	0	-	8.5	0	-	46.3
HCM Lane LOS	B	A	-	A	A	-	E
HCM 95th %tile Q(veh)	0.1	-	-	0	-	-	3.7







HCM Signalized Intersection Capacity Analysis

6: Oak St & SR-14

													
Movement	EBL	EBT	EBR	WBL	WBT	WBR	NBL	NBT	NBR	SBL	SBT	SBR	
Lane Configurations													
Traffic Volume (vph)	210	290	10	10	480	245	20	20	20	100	0	355	
Future Volume (vph)	210	290	10	10	480	245	20	20	20	100	0	355	
Ideal Flow (vphpl)	1900	1900	1900	1900	1900	1900	1900	1900	1900	1900	1900	1900	
Total Lost time (s)	4.5	4.5			4.5			4.5			4.5	4.5	
Lane Util. Factor	1.00	1.00			1.00			1.00			1.00	1.00	
Frbp, ped/bikes	1.00	1.00			0.99			0.99			1.00	0.98	
Flpb, ped/bikes	1.00	1.00			1.00			1.00			1.00	1.00	
Frt	1.00	0.99			0.95			0.95			1.00	0.85	
Flt Protected	0.95	1.00			1.00			0.98			0.95	1.00	
Satd. Flow (prot)	1752	1666			1703			1674			1716	1560	
Flt Permitted	0.95	1.00			0.99			0.88			0.77	1.00	
Satd. Flow (perm)	1752	1666			1694			1491			1383	1560	
Peak-hour factor, PHF	0.79	0.79	0.79	0.90	0.90	0.90	0.83	0.83	0.83	0.81	0.81	0.81	
Adj. Flow (vph)	266	367	13	11	533	272	24	24	24	123	0	438	
RTOR Reduction (vph)	0	1	0	0	19	0	0	20	0	0	0	367	
Lane Group Flow (vph)	266	379	0	0	797	0	0	52	0	0	123	71	
Confl. Peds. (#/hr)	6		7	7		6	2		1	1		2	
Confl. Bikes (#/hr)						1							
Heavy Vehicles (%)	3%	12%	50%	0%	7%	2%	13%	4%	0%	5%	0%	1%	
Turn Type	Prot	NA		Perm	NA		Perm	NA		Perm	NA	Perm	
Protected Phases	7	4			8			2			6		
Permitted Phases				8			2			6		6	
Actuated Green, G (s)	14.4	62.3			43.4			13.7			13.7	13.7	
Effective Green, g (s)	14.4	62.3			43.4			13.7			13.7	13.7	
Actuated g/C Ratio	0.17	0.73			0.51			0.16			0.16	0.16	
Clearance Time (s)	4.5	4.5			4.5			4.5			4.5	4.5	
Vehicle Extension (s)	3.0	3.0			3.0			3.0			3.0	3.0	
Lane Grp Cap (vph)	296	1221			864			240			222	251	
v/s Ratio Prot	c0.15	0.23											
v/s Ratio Perm					c0.47			0.03			c0.09	0.05	
v/c Ratio	0.90	0.31			0.92			0.22			0.55	0.28	
Uniform Delay, d1	34.6	3.9			19.2			31.0			32.8	31.3	
Progression Factor	1.00	1.00			0.53			1.00			1.00	1.00	
Incremental Delay, d2	27.7	0.1			10.8			0.5			3.0	0.6	
Delay (s)	62.2	4.1			21.0			31.4			35.8	31.9	
Level of Service	E	A			C			C			D	C	
Approach Delay (s)		28.0			21.0			31.4			32.8		
Approach LOS		C			C			C			C		
Intersection Summary													
HCM 2000 Control Delay			26.7									HCM 2000 Level of Service	C
HCM 2000 Volume to Capacity ratio			0.85										
Actuated Cycle Length (s)			85.0									Sum of lost time (s)	13.5
Intersection Capacity Utilization			80.5%									ICU Level of Service	D
Analysis Period (min)			15										
c Critical Lane Group													

Queues

6: Oak St & SR-14



















						
Lane Group	EBL	EBT	WBT	NBT	SBT	SBR
Lane Group Flow (vph)	266	380	816	72	123	438
v/c Ratio	0.90	0.31	0.93	0.28	0.55	0.71
Control Delay	69.0	5.2	25.2	25.1	42.5	10.3
Queue Delay	0.0	0.0	0.8	0.0	0.0	0.0
Total Delay	69.0	5.2	26.0	25.1	42.5	10.3
Queue Length 50th (ft)	143	60	108	23	61	0
Queue Length 95th (ft)	#244	94	#303	53	102	45
Internal Link Dist (ft)		229	268	100	659	
Turn Bay Length (ft)	100					75
Base Capacity (vph)	297	1229	889	344	301	682
Starvation Cap Reductn	0	0	11	0	0	0
Spillback Cap Reductn	0	0	0	0	0	0
Storage Cap Reductn	0	0	0	0	0	0
Reduced v/c Ratio	0.90	0.31	0.93	0.21	0.41	0.64

Intersection Summary

95th percentile volume exceeds capacity, queue may be longer.
Queue shown is maximum after two cycles.

HCM Signalized Intersection Capacity Analysis

7: Maple St & SR-14

													
Movement	EBL	EBT	EBR	WBL	WBT	WBR	NBL	NBT	NBR	SBL	SBT	SBR	
Lane Configurations													
Traffic Volume (vph)	10	385	20	5	625	5	95	5	25	5	5	10	
Future Volume (vph)	10	385	20	5	625	5	95	5	25	5	5	10	
Ideal Flow (vphpl)	1900	1900	1900	1900	1900	1900	1900	1900	1900	1900	1900	1900	
Total Lost time (s)		4.5	4.5		4.5			4.5	4.5		4.5		
Lane Util. Factor		1.00	1.00		1.00			1.00	1.00		1.00		
Frbp, ped/bikes		1.00	0.98		1.00			1.00	0.98		0.99		
Flpb, ped/bikes		1.00	1.00		1.00			1.00	1.00		1.00		
Frt		1.00	0.85		1.00			1.00	0.85		0.93		
Flt Protected		1.00	1.00		1.00			0.95	1.00		0.99		
Satd. Flow (prot)		1745	1472		1771			1776	1490		1704		
Flt Permitted		0.98	1.00		1.00			0.72	1.00		0.93		
Satd. Flow (perm)		1716	1472		1767			1333	1490		1605		
Peak-hour factor, PHF	0.92	0.92	0.92	0.87	0.87	0.87	0.86	0.86	0.86	0.74	0.74	0.74	
Adj. Flow (vph)	11	418	22	6	718	6	110	6	29	7	7	14	
RTOR Reduction (vph)	0	0	6	0	0	0	0	0	24	0	12	0	
Lane Group Flow (vph)	0	429	16	0	730	0	0	116	5	0	16	0	
Confl. Peds. (#/hr)	4		2	2		4	1		1	1		1	
Heavy Vehicles (%)	0%	9%	7%	22%	7%	0%	2%	0%	6%	0%	0%	3%	
Turn Type	Perm	NA	Perm	Perm	NA		Perm	NA	Perm	Perm	NA		
Protected Phases		4			8			2				6	
Permitted Phases	4		4	8			2		2	6			
Actuated Green, G (s)		62.3	62.3		43.4			13.7	13.7			13.7	
Effective Green, g (s)		62.3	62.3		43.4			13.7	13.7			13.7	
Actuated g/C Ratio		0.73	0.73		0.51			0.16	0.16			0.16	
Clearance Time (s)		4.5	4.5		4.5			4.5	4.5			4.5	
Vehicle Extension (s)		3.0	3.0		3.0			3.0	3.0			3.0	
Lane Grp Cap (vph)		1257	1078		902			214	240			258	
v/s Ratio Prot													
v/s Ratio Perm		c0.25	0.01		c0.41			c0.09	0.00			0.01	
v/c Ratio		0.34	0.01		0.81			0.54	0.02			0.06	
Uniform Delay, d1		4.0	3.1		17.3			32.8	30.0			30.2	
Progression Factor		0.98	1.01		1.00			1.00	1.00			1.00	
Incremental Delay, d2		0.2	0.0		5.4			2.8	0.0			0.1	
Delay (s)		4.1	3.1		22.7			35.6	30.0			30.3	
Level of Service		A	A		C			D	C			C	
Approach Delay (s)		4.1			22.7			34.5				30.3	
Approach LOS		A			C			C				C	
Intersection Summary													
HCM 2000 Control Delay			17.9									HCM 2000 Level of Service	B
HCM 2000 Volume to Capacity ratio			0.67										
Actuated Cycle Length (s)			85.0									Sum of lost time (s)	13.5
Intersection Capacity Utilization			57.0%									ICU Level of Service	B
Analysis Period (min)			15										
c	Critical Lane Group												

Queues

7: Maple St & SR-14

	→	↘	←	↑	↗	↓
Lane Group	EBT	EBR	WBT	NBT	NBR	SBT
Lane Group Flow (vph)	429	22	730	116	29	28
v/c Ratio	0.34	0.02	0.81	0.54	0.10	0.10
Control Delay	5.3	1.9	27.3	42.4	0.6	20.3
Queue Delay	0.4	0.0	0.0	0.0	0.0	0.0
Total Delay	5.7	1.9	27.3	42.4	0.6	20.3
Queue Length 50th (ft)	89	0	317	58	0	6
Queue Length 95th (ft)	130	m6	#540	105	0	22
Internal Link Dist (ft)	268		860	365		666
Turn Bay Length (ft)		80				
Base Capacity (vph)	1265	1090	909	290	382	360
Starvation Cap Reductn	408	0	0	0	0	0
Spillback Cap Reductn	0	0	0	0	0	0
Storage Cap Reductn	0	0	0	0	0	0
Reduced v/c Ratio	0.50	0.02	0.80	0.40	0.08	0.08

Intersection Summary

95th percentile volume exceeds capacity, queue may be longer.

Queue shown is maximum after two cycles.

m Volume for 95th percentile queue is metered by upstream signal.

HCM 2010 Roundabout
28: SR-14

Intersection				
Intersection Delay, s/veh	10.7			
Intersection LOS	B			
Approach	EB	WB	NB	SB
Entry Lanes	1	1	1	1
Conflicting Circle Lanes	1	1	1	1
Adj Approach Flow, veh/h	456	434	321	54
Demand Flow Rate, veh/h	496	465	330	55
Vehicles Circulating, veh/h	38	255	466	710
Vehicles Exiting, veh/h	727	541	68	10
Follow-Up Headway, s	3.186	3.186	3.186	3.186
Ped Vol Crossing Leg, #/h	0	0	0	0
Ped Cap Adj	1.000	1.000	1.000	1.000
Approach Delay, s/veh	8.9	11.9	12.0	7.8
Approach LOS	A	B	B	A
Lane	Left	Left	Left	Left
Designated Moves	LTR	LTR	LTR	LTR
Assumed Moves	LTR	LTR	LTR	LTR
RT Channelized				
Lane Util	1.000	1.000	1.000	1.000
Critical Headway, s	5.193	5.193	5.193	5.193
Entry Flow, veh/h	496	465	330	55
Cap Entry Lane, veh/h	1088	876	709	556
Entry HV Adj Factor	0.919	0.934	0.973	0.982
Flow Entry, veh/h	456	434	321	54
Cap Entry, veh/h	1000	818	690	545
V/C Ratio	0.456	0.531	0.465	0.099
Control Delay, s/veh	8.9	11.9	12.0	7.8
LOS	A	B	B	A
95th %tile Queue, veh	2	3	2	0

HCM 2010 TWSC
1: SR-14 & SR-141

Intersection

Int Delay, s/veh 7.1

Movement	EBL	EBT	WBT	WBR	SBL	SBR
Traffic Vol, veh/h	55	290	470	220	115	60
Future Vol, veh/h	55	290	470	220	115	60
Conflicting Peds, #/hr	0	0	0	0	0	0
Sign Control	Free	Free	Free	Free	Stop	Stop
RT Channelized	-	None	-	Free	-	None
Storage Length	-	-	-	-	0	-
Veh in Median Storage, #	-	0	0	-	0	-
Grade, %	-	0	0	-	0	-
Peak Hour Factor	86	86	87	87	88	88
Heavy Vehicles, %	4	11	5	2	6	7
Mvmt Flow	64	337	540	253	131	68

Major/Minor	Major1	Major2	Minor2
Conflicting Flow All	540	0	540
Stage 1	-	-	540
Stage 2	-	-	465
Critical Hdwy	4.14	-	6.27
Critical Hdwy Stg 1	-	-	5.46
Critical Hdwy Stg 2	-	-	5.46
Follow-up Hdwy	2.236	-	3.363
Pot Cap-1 Maneuver	1018	0	532
Stage 1	-	0	576
Stage 2	-	0	624
Platoon blocked, %	-	-	-
Mov Cap-1 Maneuver	1018	-	532
Mov Cap-2 Maneuver	-	-	243
Stage 1	-	-	576
Stage 2	-	-	576

Approach	EB	WB	SB
HCM Control Delay, s	1.4	0	38
HCM LOS			E

Minor Lane/Major Mvmt	EBL	EBT	WBT	SBLn1
Capacity (veh/h)	1018	-	-	299
HCM Lane V/C Ratio	0.063	-	-	0.665
HCM Control Delay (s)	8.8	0	-	38
HCM Lane LOS	A	A	-	E
HCM 95th %tile Q(veh)	0.2	-	-	4.4

HCM 2010 TWSC
2: SR-14 & Dock Grade Rd

Intersection												
Int Delay, s/veh	1.1											

Movement	EBL	EBT	EBR	WBL	WBT	WBR	NBL	NBT	NBR	SBL	SBT	SBR
Traffic Vol, veh/h	60	340	5	10	675	350	15	5	5	0	0	0
Future Vol, veh/h	60	340	5	10	675	350	15	5	5	0	0	0
Conflicting Peds, #/hr	0	0	0	0	0	0	0	0	0	0	0	0
Sign Control	Free	Free	Free	Free	Free	Free	Stop	Stop	Stop	Stop	Stop	Stop
RT Channelized	-	-	None	-	-	None	-	-	None	-	-	None
Storage Length	125	-	-	125	-	325	-	-	-	-	-	-
Veh in Median Storage, #	-	0	-	-	0	-	-	0	-	-	0	-
Grade, %	-	0	-	-	0	-	-	0	-	-	0	-
Peak Hour Factor	86	86	86	91	91	91	67	67	67	92	92	92
Heavy Vehicles, %	1	14	8	0	21	5	0	0	0	2	2	2
Mvmt Flow	70	395	6	11	742	385	22	7	7	0	0	0

Major/Minor	Major1			Major2			Minor1		
Conflicting Flow All	742	0	0	401	0	0	1302	1302	398
Stage 1	-	-	-	-	-	-	538	538	-
Stage 2	-	-	-	-	-	-	764	764	-
Critical Hdwy	4.11	-	-	4.1	-	-	6.4	6.5	6.2
Critical Hdwy Stg 1	-	-	-	-	-	-	5.4	5.5	-
Critical Hdwy Stg 2	-	-	-	-	-	-	5.4	5.5	-
Follow-up Hdwy	2.209	-	-	2.2	-	-	3.5	4	3.3
Pot Cap-1 Maneuver	870	-	-	1169	-	-	179	162	656
Stage 1	-	-	-	-	-	-	589	526	-
Stage 2	-	-	-	-	-	-	463	416	-
Platoon blocked, %	-	-	-	-	-	-	-	-	-
Mov Cap-1 Maneuver	870	-	-	1169	-	-	163	0	656
Mov Cap-2 Maneuver	-	-	-	-	-	-	163	0	-
Stage 1	-	-	-	-	-	-	542	0	-
Stage 2	-	-	-	-	-	-	459	0	-

Approach	EB	WB	NB
HCM Control Delay, s	1.4	0.1	26.9
HCM LOS			D

Minor Lane/Major Mvmt	NBLn1	EBL	EBT	EBR	WBL	WBT	WBR
Capacity (veh/h)	201	870	-	-	1169	-	-
HCM Lane V/C Ratio	0.186	0.08	-	-	0.009	-	-
HCM Control Delay (s)	26.9	9.5	-	-	8.1	-	-
HCM Lane LOS	D	A	-	-	A	-	-
HCM 95th %tile Q(veh)	0.7	0.3	-	-	0	-	-

HCM Signalized Intersection Capacity Analysis

3: Hood River Bridge & SR-14

	→	↘	↙	←	↖	↗
Movement	EBT	EBR	WBL	WBT	NBL	NBR
Lane Configurations	↑	↗	↘	↑	↘	↗
Traffic Volume (vph)	150	195	605	395	640	280
Future Volume (vph)	150	195	605	395	640	280
Ideal Flow (vphpl)	1900	1900	1900	1900	1900	1900
Total Lost time (s)	5.0	5.0	4.0	5.0	5.0	5.0
Lane Util. Factor	1.00	1.00	1.00	1.00	1.00	1.00
Frpb, ped/bikes	1.00	1.00	1.00	1.00	1.00	1.00
Flpb, ped/bikes	1.00	1.00	1.00	1.00	1.00	1.00
Frt	1.00	0.85	1.00	1.00	1.00	0.85
Flt Protected	1.00	1.00	0.95	1.00	0.95	1.00
Satd. Flow (prot)	1545	1509	1770	1792	1787	1553
Flt Permitted	1.00	1.00	0.95	1.00	0.95	1.00
Satd. Flow (perm)	1545	1509	1770	1792	1787	1553
Peak-hour factor, PHF	0.84	0.84	0.97	0.97	0.89	0.89
Adj. Flow (vph)	179	232	624	407	719	315
RTOR Reduction (vph)	0	28	0	0	0	77
Lane Group Flow (vph)	179	204	624	407	719	238
Confl. Peds. (#/hr)		1	1			1
Heavy Vehicles (%)	23%	7%	2%	6%	1%	4%
Turn Type	NA	pt+ov	Prot	NA	Prot	pt+ov
Protected Phases	2	2 8	1	6	8	8 1
Permitted Phases						
Actuated Green, G (s)	27.0	74.0	37.0	68.0	42.0	84.0
Effective Green, g (s)	27.0	74.0	37.0	68.0	42.0	84.0
Actuated g/C Ratio	0.22	0.62	0.31	0.57	0.35	0.70
Clearance Time (s)	5.0		4.0	5.0	5.0	
Vehicle Extension (s)	3.0		3.0	3.0	3.0	
Lane Grp Cap (vph)	347	930	545	1015	625	1087
v/s Ratio Prot	c0.12	0.14	c0.35	0.23	c0.40	0.15
v/s Ratio Perm						
v/c Ratio	0.52	0.22	1.14	0.40	1.15	0.22
Uniform Delay, d1	40.8	10.2	41.5	14.6	39.0	6.4
Progression Factor	1.00	1.00	1.00	1.00	1.00	1.00
Incremental Delay, d2	5.4	0.1	85.2	0.3	85.2	0.1
Delay (s)	46.2	10.3	126.7	14.8	124.2	6.5
Level of Service	D	B	F	B	F	A
Approach Delay (s)	25.9			82.5	88.3	
Approach LOS	C			F	F	
Intersection Summary						
HCM 2000 Control Delay			75.6		HCM 2000 Level of Service	E
HCM 2000 Volume to Capacity ratio			0.99			
Actuated Cycle Length (s)			120.0		Sum of lost time (s)	14.0
Intersection Capacity Utilization			102.3%		ICU Level of Service	G
Analysis Period (min)			15			

c Critical Lane Group

Queues

3: Hood River Bridge & SR-14

	→	↘	↙	←	↖	↗
Lane Group	EBT	EBR	WBL	WBT	NBL	NBR
Lane Group Flow (vph)	179	232	624	407	719	315
v/c Ratio	0.52	0.24	1.14	0.40	1.15	0.27
Control Delay	46.9	7.6	123.6	16.1	121.5	2.0
Queue Delay	0.0	0.0	0.0	0.0	0.0	0.0
Total Delay	46.9	7.6	123.6	16.1	121.5	2.0
Queue Length 50th (ft)	122	49	~566	168	~655	13
Queue Length 95th (ft)	182	79	#792	241	#874	40
Internal Link Dist (ft)	1219			2070	431	
Turn Bay Length (ft)		250	125			125
Base Capacity (vph)	347	958	545	1015	625	1153
Starvation Cap Reductn	0	0	0	0	0	0
Spillback Cap Reductn	0	0	0	0	0	0
Storage Cap Reductn	0	0	0	0	0	0
Reduced v/c Ratio	0.52	0.24	1.14	0.40	1.15	0.27

Intersection Summary

- ~ Volume exceeds capacity, queue is theoretically infinite.
Queue shown is maximum after two cycles.
- # 95th percentile volume exceeds capacity, queue may be longer.
Queue shown is maximum after two cycles.

HCM 2010 TWSC
4: Walnut St & SR-14

Intersection												
Int Delay, s/veh	14.3											

Movement	EBL	EBT	EBR	WBL	WBT	WBR	NBL	NBT	NBR	SBL	SBT	SBR
Traffic Vol, veh/h	10	470	10	15	895	25	35	5	40	5	5	20
Future Vol, veh/h	10	470	10	15	895	25	35	5	40	5	5	20
Conflicting Peds, #/hr	13	0	12	12	0	13	6	0	11	11	0	6
Sign Control	Free	Free	Free	Free	Free	Free	Stop	Stop	Stop	Stop	Stop	Stop
RT Channelized	-	-	None	-	-	None	-	-	None	-	-	None
Storage Length	-	-	-	-	-	-	-	-	-	-	-	-
Veh in Median Storage, #	-	0	-	-	0	-	-	0	-	-	0	-
Grade, %	-	0	-	-	0	-	-	0	-	-	0	-
Peak Hour Factor	81	81	81	92	92	92	65	65	65	73	73	73
Heavy Vehicles, %	0	8	8	5	4	4	2	0	0	0	0	3
Mvmt Flow	12	580	12	16	973	27	54	8	62	7	7	27

Major/Minor	Major1			Major2			Minor1			Minor2		
Conflicting Flow All	1011	0	0	604	0	0	1669	1666	610	1687	1658	1010
Stage 1	-	-	-	-	-	-	622	622	-	1030	1030	-
Stage 2	-	-	-	-	-	-	1047	1044	-	657	628	-
Critical Hdwy	4.1	-	-	4.15	-	-	7.12	6.5	6.2	7.1	6.5	6.23
Critical Hdwy Stg 1	-	-	-	-	-	-	6.12	5.5	-	6.1	5.5	-
Critical Hdwy Stg 2	-	-	-	-	-	-	6.12	5.5	-	6.1	5.5	-
Follow-up Hdwy	2.2	-	-	2.245	-	-	3.518	4	3.3	3.5	4	3.327
Pot Cap-1 Maneuver	694	-	-	959	-	-	76	98	498	75	99	290
Stage 1	-	-	-	-	-	-	474	482	-	284	313	-
Stage 2	-	-	-	-	-	-	276	309	-	457	479	-
Platoon blocked, %	-	-	-	-	-	-	-	-	-	-	-	-
Mov Cap-1 Maneuver	685	-	-	947	-	-	60	90	487	57	91	283
Mov Cap-2 Maneuver	-	-	-	-	-	-	60	90	-	57	91	-
Stage 1	-	-	-	-	-	-	457	465	-	274	298	-
Stage 2	-	-	-	-	-	-	231	294	-	378	462	-

Approach	EB	WB	NB	SB
HCM Control Delay, s	0.2	0.1	191.5	40.7
HCM LOS			F	E

Minor Lane/Major Mvmt	NBLn1	EBL	EBT	EBR	WBL	WBT	WBR	SBLn1
Capacity (veh/h)	111	685	-	-	947	-	-	141
HCM Lane V/C Ratio	1.109	0.018	-	-	0.017	-	-	0.291
HCM Control Delay (s)	191.5	10.4	0	-	8.9	0	-	40.7
HCM Lane LOS	F	B	A	-	A	A	-	E
HCM 95th %tile Q(veh)	7.6	0.1	-	-	0.1	-	-	1.1

HCM 2010 TWSC
5: Ash St & SR-14

Intersection												
Int Delay, s/veh	3.9											

Movement	EBL	EBT	EBR	WBL	WBT	WBR	NBL	NBT	NBR	SBL	SBT	SBR
Traffic Vol, veh/h	25	485	10	5	850	10	0	0	0	20	0	80
Future Vol, veh/h	25	485	10	5	850	10	0	0	0	20	0	80
Conflicting Peds, #/hr	3	0	9	9	0	3	8	0	8	8	0	8
Sign Control	Free	Free	Free	Free	Free	Free	Stop	Stop	Stop	Stop	Stop	Stop
RT Channelized	-	-	None	-	-	None	-	-	None	-	-	None
Storage Length	-	-	-	-	-	-	-	-	-	-	-	-
Veh in Median Storage, #	-	0	-	-	0	-	-	0	-	-	0	-
Grade, %	-	0	-	-	0	-	-	0	-	-	0	-
Peak Hour Factor	90	90	90	88	88	88	92	92	92	73	73	73
Heavy Vehicles, %	7	6	0	0	5	0	2	2	2	8	0	0
Mvmt Flow	28	539	11	6	966	11	0	0	0	27	0	110

Major/Minor	Major1			Major2			Minor2		
Conflicting Flow All	985	0	0	550	0	0	1591	1597	989
Stage 1	-	-	-	-	-	-	991	991	-
Stage 2	-	-	-	-	-	-	600	606	-
Critical Hdwy	4.17	-	-	4.1	-	-	6.48	6.5	6.2
Critical Hdwy Stg 1	-	-	-	-	-	-	5.48	5.5	-
Critical Hdwy Stg 2	-	-	-	-	-	-	5.48	5.5	-
Follow-up Hdwy	2.263	-	-	2.2	-	-	3.572	4	3.3
Pot Cap-1 Maneuver	682	-	-	1030	-	-	114	108	302
Stage 1	-	-	-	-	-	-	350	327	-
Stage 2	-	-	-	-	-	-	537	490	-
Platoon blocked, %	-	-	-	-	-	-	-	-	-
Mov Cap-1 Maneuver	676	-	-	1021	-	-	104	0	297
Mov Cap-2 Maneuver	-	-	-	-	-	-	104	0	-
Stage 1	-	-	-	-	-	-	343	0	-
Stage 2	-	-	-	-	-	-	501	0	-

Approach	EB	WB	SB
HCM Control Delay, s	0.5	0	46.3
HCM LOS			E

Minor Lane/Major Mvmt	EBL	EBT	EBR	WBL	WBT	WBR	SBLn1
Capacity (veh/h)	676	-	-	1021	-	-	217
HCM Lane V/C Ratio	0.041	-	-	0.006	-	-	0.631
HCM Control Delay (s)	10.6	0	-	8.5	0	-	46.3
HCM Lane LOS	B	A	-	A	A	-	E
HCM 95th %tile Q(veh)	0.1	-	-	0	-	-	3.7

HCM 2010 AWSC
6: Oak St & SR-14

Intersection												
Intersection Delay, s/veh	48.1											
Intersection LOS	E											
Movement	EBU	EBL	EBT	EBR	WBU	WBL	WBT	WBR	NBU	NBL	NBT	NBR
Traffic Vol, veh/h	0	210	290	10	0	10	480	245	0	20	20	20
Future Vol, veh/h	0	210	290	10	0	10	480	245	0	20	20	20
Peak Hour Factor	0.86	0.79	0.79	0.79	0.91	0.90	0.90	0.90	0.92	0.83	0.83	0.83
Heavy Vehicles, %	1	3	12	50	0	0	7	2	2	13	4	0
Mvmt Flow	0	266	367	13	0	11	533	272	0	24	24	24
Number of Lanes	0	1	1	0	0	0	1	0	0	0	1	0
Approach	EB			WB			NB					
Opposing Approach	WB			EB			SB					
Opposing Lanes	1			2			2					
Conflicting Approach Left	SB			NB			EB					
Conflicting Lanes Left	2			1			2					
Conflicting Approach Right	NB			SB			WB					
Conflicting Lanes Right	1			2			1					
HCM Control Delay	33.6			70			15.3					
HCM LOS	D			F			C					
Lane	NBLn1	EBLn1	EBLn2	WBLn1	SBLn1	SBLn2						
Vol Left, %	33%	100%	0%	1%	100%	0%						
Vol Thru, %	33%	0%	97%	65%	0%	0%						
Vol Right, %	33%	0%	3%	33%	0%	100%						
Sign Control	Stop	Stop	Stop	Stop	Stop	Stop						
Traffic Vol by Lane	60	210	300	735	100	355						
LT Vol	20	210	0	10	100	0						
Through Vol	20	0	290	480	0	0						
RT Vol	20	0	10	245	0	355						
Lane Flow Rate	72	266	380	817	123	438						
Geometry Grp	6	7	7	6	7	7						
Degree of Util (X)	0.197	0.616	0.84	1	0.293	0.883						
Departure Headway (Hd)	9.813	8.336	7.965	7.687	8.541	7.257						
Convergence, Y/N	Yes	Yes	Yes	Yes	Yes	Yes						
Cap	364	433	456	474	421	500						
Service Time	7.905	6.104	5.733	5.783	6.291	5.006						
HCM Lane V/C Ratio	0.198	0.614	0.833	1.724	0.292	0.876						
HCM Control Delay	15.3	23.7	40.6	70	14.8	43.6						
HCM Lane LOS	C	C	E	F	B	E						
HCM 95th-tile Q	0.7	4	8.2	13.2	1.2	9.7						

HCM 2010 AWSC
 6: Oak St & SR-14

Intersection

Intersection Delay, s/veh
 Intersection LOS

Movement	SBU	SBL	SBT	SBR
Traffic Vol, veh/h	0	100	0	355
Future Vol, veh/h	0	100	0	355
Peak Hour Factor	0.92	0.81	0.81	0.81
Heavy Vehicles, %	2	5	0	1
Mvmt Flow	0	123	0	438
Number of Lanes	0	0	1	1

Approach	SB
Opposing Approach	NB
Opposing Lanes	1
Conflicting Approach Left	WB
Conflicting Lanes Left	1
Conflicting Approach Right	EB
Conflicting Lanes Right	2
HCM Control Delay	37.3
HCM LOS	E

Lane

HCM 2010 TWSC
7: Maple St & SR-14

Intersection												
Int Delay, s/veh	7.6											

Movement	EBL	EBT	EBR	WBL	WBT	WBR	NBL	NBT	NBR	SBL	SBT	SBR
Traffic Vol, veh/h	10	385	20	5	625	5	95	5	25	5	5	10
Future Vol, veh/h	10	385	20	5	625	5	95	5	25	5	5	10
Conflicting Peds, #/hr	4	0	2	2	0	4	1	0	1	1	0	1
Sign Control	Free	Free	Free	Free	Free	Free	Stop	Stop	Stop	Stop	Stop	Stop
RT Channelized	-	-	None	-	-	None	-	-	None	-	-	None
Storage Length	-	-	80	-	-	-	-	-	0	-	-	-
Veh in Median Storage, #	-	0	-	-	0	-	-	0	-	-	0	-
Grade, %	-	0	-	-	0	-	-	0	-	-	0	-
Peak Hour Factor	92	92	92	87	87	87	86	86	86	74	74	74
Heavy Vehicles, %	0	9	7	22	7	0	2	0	6	0	0	3
Mvmt Flow	11	418	22	6	718	6	110	6	29	7	7	14

Major/Minor	Major1			Major2			Minor1			Minor2		
Conflicting Flow All	725	0	0	419	0	0	1185	1178	423	1178	1175	726
Stage 1	-	-	-	-	-	-	441	441	-	734	734	-
Stage 2	-	-	-	-	-	-	744	737	-	444	441	-
Critical Hdwy	4.1	-	-	4.32	-	-	7.12	6.5	6.26	7.1	6.5	6.23
Critical Hdwy Stg 1	-	-	-	-	-	-	6.12	5.5	-	6.1	5.5	-
Critical Hdwy Stg 2	-	-	-	-	-	-	6.12	5.5	-	6.1	5.5	-
Follow-up Hdwy	2.2	-	-	2.398	-	-	3.518	4	3.354	3.5	4	3.327
Pot Cap-1 Maneuver	887	-	-	1041	-	-	166	192	622	169	193	423
Stage 1	-	-	-	-	-	-	595	580	-	415	429	-
Stage 2	-	-	-	-	-	-	407	428	-	597	580	-
Platoon blocked, %	-	-	-	-	-	-	-	-	-	-	-	-
Mov Cap-1 Maneuver	884	-	-	1037	-	-	152	186	619	153	187	421
Mov Cap-2 Maneuver	-	-	-	-	-	-	152	186	-	153	187	-
Stage 1	-	-	-	-	-	-	584	570	-	408	424	-
Stage 2	-	-	-	-	-	-	382	423	-	551	570	-

Approach	EB	WB	NB	SB
HCM Control Delay, s	0.2	0.1	65.6	21.9
HCM LOS			F	C

Minor Lane/Major Mvmt	NBLn1	NBLn2	EBL	EBT	EBR	WBL	WBT	WBR	SBLn1
Capacity (veh/h)	153	619	884	-	-	1037	-	-	240
HCM Lane V/C Ratio	0.76	0.047	0.012	-	-	0.006	-	-	0.113
HCM Control Delay (s)	79.2	11.1	9.1	0	-	8.5	0	-	21.9
HCM Lane LOS	F	B	A	A	-	A	A	-	C
HCM 95th %tile Q(veh)	4.7	0.1	0	-	-	0	-	-	0.4

HCM 2010 Roundabout
28: SR-14

Intersection				
Intersection Delay, s/veh	10.7			
Intersection LOS	B			
Approach	EB	WB	NB	SB
Entry Lanes	1	1	1	1
Conflicting Circle Lanes	1	1	1	1
Adj Approach Flow, veh/h	456	434	321	54
Demand Flow Rate, veh/h	496	465	330	55
Vehicles Circulating, veh/h	38	255	466	710
Vehicles Exiting, veh/h	727	541	68	10
Follow-Up Headway, s	3.186	3.186	3.186	3.186
Ped Vol Crossing Leg, #/h	0	0	0	0
Ped Cap Adj	1.000	1.000	1.000	1.000
Approach Delay, s/veh	8.9	11.9	12.0	7.8
Approach LOS	A	B	B	A
Lane	Left	Left	Left	Left
Designated Moves	LTR	LTR	LTR	LTR
Assumed Moves	LTR	LTR	LTR	LTR
RT Channelized				
Lane Util	1.000	1.000	1.000	1.000
Critical Headway, s	5.193	5.193	5.193	5.193
Entry Flow, veh/h	496	465	330	55
Cap Entry Lane, veh/h	1088	876	709	556
Entry HV Adj Factor	0.919	0.934	0.973	0.982
Flow Entry, veh/h	456	434	321	54
Cap Entry, veh/h	1000	818	690	545
V/C Ratio	0.456	0.531	0.465	0.099
Control Delay, s/veh	8.9	11.9	12.0	7.8
LOS	A	B	B	A
95th %tile Queue, veh	2	3	2	0

HCM 2010 TWSC
1: SR-14 & SR-141

Intersection

Int Delay, s/veh 7.1

Movement	EBL	EBT	WBT	WBR	SBL	SBR
Traffic Vol, veh/h	55	290	470	220	115	60
Future Vol, veh/h	55	290	470	220	115	60
Conflicting Peds, #/hr	0	0	0	0	0	0
Sign Control	Free	Free	Free	Free	Stop	Stop
RT Channelized	-	None	-	Free	-	None
Storage Length	-	-	-	-	0	-
Veh in Median Storage, #	-	0	0	-	0	-
Grade, %	-	0	0	-	0	-
Peak Hour Factor	86	86	87	87	88	88
Heavy Vehicles, %	4	11	5	2	6	7
Mvmt Flow	64	337	540	253	131	68

Major/Minor	Major1	Major2	Minor2
Conflicting Flow All	540	0	540
Stage 1	-	-	540
Stage 2	-	-	465
Critical Hdwy	4.14	-	6.27
Critical Hdwy Stg 1	-	-	5.46
Critical Hdwy Stg 2	-	-	5.46
Follow-up Hdwy	2.236	-	3.363
Pot Cap-1 Maneuver	1018	0	532
Stage 1	-	0	576
Stage 2	-	0	624
Platoon blocked, %	-	-	-
Mov Cap-1 Maneuver	1018	-	532
Mov Cap-2 Maneuver	-	-	243
Stage 1	-	-	576
Stage 2	-	-	576

Approach	EB	WB	SB
HCM Control Delay, s	1.4	0	38
HCM LOS			E

Minor Lane/Major Mvmt	EBL	EBT	WBT	SBLn1
Capacity (veh/h)	1018	-	-	299
HCM Lane V/C Ratio	0.063	-	-	0.665
HCM Control Delay (s)	8.8	0	-	38
HCM Lane LOS	A	A	-	E
HCM 95th %tile Q(veh)	0.2	-	-	4.4

HCM 2010 TWSC
 2: SR-14 & Dock Grade Rd

Intersection												
Int Delay, s/veh	1.1											

Movement	EBL	EBT	EBR	WBL	WBT	WBR	NBL	NBT	NBR	SBL	SBT	SBR
Traffic Vol, veh/h	60	340	5	10	675	350	15	5	5	0	0	0
Future Vol, veh/h	60	340	5	10	675	350	15	5	5	0	0	0
Conflicting Peds, #/hr	0	0	0	0	0	0	0	0	0	0	0	0
Sign Control	Free	Free	Free	Free	Free	Free	Stop	Stop	Stop	Stop	Stop	Stop
RT Channelized	-	-	None	-	-	None	-	-	None	-	-	None
Storage Length	125	-	-	125	-	325	-	-	-	-	-	-
Veh in Median Storage, #	-	0	-	-	0	-	-	0	-	-	0	-
Grade, %	-	0	-	-	0	-	-	0	-	-	0	-
Peak Hour Factor	86	86	86	91	91	91	67	67	67	92	92	92
Heavy Vehicles, %	1	14	8	0	21	5	0	0	0	2	2	2
Mvmt Flow	70	395	6	11	742	385	22	7	7	0	0	0

Major/Minor	Major1			Major2			Minor1		
Conflicting Flow All	742	0	0	401	0	0	1302	1302	398
Stage 1	-	-	-	-	-	-	538	538	-
Stage 2	-	-	-	-	-	-	764	764	-
Critical Hdwy	4.11	-	-	4.1	-	-	6.4	6.5	6.2
Critical Hdwy Stg 1	-	-	-	-	-	-	5.4	5.5	-
Critical Hdwy Stg 2	-	-	-	-	-	-	5.4	5.5	-
Follow-up Hdwy	2.209	-	-	2.2	-	-	3.5	4	3.3
Pot Cap-1 Maneuver	870	-	-	1169	-	-	179	162	656
Stage 1	-	-	-	-	-	-	589	526	-
Stage 2	-	-	-	-	-	-	463	416	-
Platoon blocked, %	-	-	-	-	-	-	-	-	-
Mov Cap-1 Maneuver	870	-	-	1169	-	-	163	0	656
Mov Cap-2 Maneuver	-	-	-	-	-	-	163	0	-
Stage 1	-	-	-	-	-	-	542	0	-
Stage 2	-	-	-	-	-	-	459	0	-

Approach	EB	WB	NB
HCM Control Delay, s	1.4	0.1	26.9
HCM LOS			D

Minor Lane/Major Mvmt	NBLn1	EBL	EBT	EBR	WBL	WBT	WBR
Capacity (veh/h)	201	870	-	-	1169	-	-
HCM Lane V/C Ratio	0.186	0.08	-	-	0.009	-	-
HCM Control Delay (s)	26.9	9.5	-	-	8.1	-	-
HCM Lane LOS	D	A	-	-	A	-	-
HCM 95th %tile Q(veh)	0.7	0.3	-	-	0	-	-

HCM Signalized Intersection Capacity Analysis

3: Hood River Bridge & SR-14

	→	↘	↙	←	↖	↗
Movement	EBT	EBR	WBL	WBT	NBL	NBR
Lane Configurations	↑	↗	↘	↑	↘	↗
Traffic Volume (vph)	150	195	605	395	640	280
Future Volume (vph)	150	195	605	395	640	280
Ideal Flow (vphpl)	1900	1900	1900	1900	1900	1900
Total Lost time (s)	5.0	5.0	4.0	5.0	5.0	5.0
Lane Util. Factor	1.00	1.00	1.00	1.00	1.00	1.00
Frpb, ped/bikes	1.00	1.00	1.00	1.00	1.00	1.00
Flpb, ped/bikes	1.00	1.00	1.00	1.00	1.00	1.00
Frt	1.00	0.85	1.00	1.00	1.00	0.85
Flt Protected	1.00	1.00	0.95	1.00	0.95	1.00
Satd. Flow (prot)	1545	1509	1770	1792	1787	1553
Flt Permitted	1.00	1.00	0.95	1.00	0.95	1.00
Satd. Flow (perm)	1545	1509	1770	1792	1787	1553
Peak-hour factor, PHF	0.84	0.84	0.97	0.97	0.89	0.89
Adj. Flow (vph)	179	232	624	407	719	315
RTOR Reduction (vph)	0	28	0	0	0	77
Lane Group Flow (vph)	179	204	624	407	719	238
Confl. Peds. (#/hr)		1	1			1
Heavy Vehicles (%)	23%	7%	2%	6%	1%	4%
Turn Type	NA	pt+ov	Prot	NA	Prot	pt+ov
Protected Phases	2	2 8	1	6	8	8 1
Permitted Phases						
Actuated Green, G (s)	27.0	74.0	37.0	68.0	42.0	84.0
Effective Green, g (s)	27.0	74.0	37.0	68.0	42.0	84.0
Actuated g/C Ratio	0.22	0.62	0.31	0.57	0.35	0.70
Clearance Time (s)	5.0		4.0	5.0	5.0	
Vehicle Extension (s)	3.0		3.0	3.0	3.0	
Lane Grp Cap (vph)	347	930	545	1015	625	1087
v/s Ratio Prot	c0.12	0.14	c0.35	0.23	c0.40	0.15
v/s Ratio Perm						
v/c Ratio	0.52	0.22	1.14	0.40	1.15	0.22
Uniform Delay, d1	40.8	10.2	41.5	14.6	39.0	6.4
Progression Factor	1.00	1.00	1.00	1.00	1.00	1.00
Incremental Delay, d2	5.4	0.1	85.2	0.3	85.2	0.1
Delay (s)	46.2	10.3	126.7	14.8	124.2	6.5
Level of Service	D	B	F	B	F	A
Approach Delay (s)	25.9			82.5	88.3	
Approach LOS	C			F	F	
Intersection Summary						
HCM 2000 Control Delay			75.6		HCM 2000 Level of Service	E
HCM 2000 Volume to Capacity ratio			0.99			
Actuated Cycle Length (s)			120.0		Sum of lost time (s)	14.0
Intersection Capacity Utilization			102.3%		ICU Level of Service	G
Analysis Period (min)			15			

c Critical Lane Group

Queues

3: Hood River Bridge & SR-14

	→	↘	↙	←	↖	↗
Lane Group	EBT	EBR	WBL	WBT	NBL	NBR
Lane Group Flow (vph)	179	232	624	407	719	315
v/c Ratio	0.52	0.24	1.14	0.40	1.15	0.27
Control Delay	46.9	7.6	123.6	16.1	121.5	2.0
Queue Delay	0.0	0.0	0.0	0.0	0.0	0.0
Total Delay	46.9	7.6	123.6	16.1	121.5	2.0
Queue Length 50th (ft)	122	49	~566	168	~655	13
Queue Length 95th (ft)	182	79	#792	241	#874	40
Internal Link Dist (ft)	1219			2070	431	
Turn Bay Length (ft)		250	125			125
Base Capacity (vph)	347	958	545	1015	625	1153
Starvation Cap Reductn	0	0	0	0	0	0
Spillback Cap Reductn	0	0	0	0	0	0
Storage Cap Reductn	0	0	0	0	0	0
Reduced v/c Ratio	0.52	0.24	1.14	0.40	1.15	0.27

Intersection Summary

- ~ Volume exceeds capacity, queue is theoretically infinite.
Queue shown is maximum after two cycles.
- # 95th percentile volume exceeds capacity, queue may be longer.
Queue shown is maximum after two cycles.

HCM 2010 TWSC
4: Walnut St & SR-14

Intersection												
Int Delay, s/veh	14.3											

Movement	EBL	EBT	EBR	WBL	WBT	WBR	NBL	NBT	NBR	SBL	SBT	SBR
Traffic Vol, veh/h	10	470	10	15	895	25	35	5	40	5	5	20
Future Vol, veh/h	10	470	10	15	895	25	35	5	40	5	5	20
Conflicting Peds, #/hr	13	0	12	12	0	13	6	0	11	11	0	6
Sign Control	Free	Free	Free	Free	Free	Free	Stop	Stop	Stop	Stop	Stop	Stop
RT Channelized	-	-	None	-	-	None	-	-	None	-	-	None
Storage Length	-	-	-	-	-	-	-	-	-	-	-	-
Veh in Median Storage, #	-	0	-	-	0	-	-	0	-	-	0	-
Grade, %	-	0	-	-	0	-	-	0	-	-	0	-
Peak Hour Factor	81	81	81	92	92	92	65	65	65	73	73	73
Heavy Vehicles, %	0	8	8	5	4	4	2	0	0	0	0	3
Mvmt Flow	12	580	12	16	973	27	54	8	62	7	7	27

Major/Minor	Major1			Major2			Minor1			Minor2		
Conflicting Flow All	1011	0	0	604	0	0	1669	1666	610	1687	1658	1010
Stage 1	-	-	-	-	-	-	622	622	-	1030	1030	-
Stage 2	-	-	-	-	-	-	1047	1044	-	657	628	-
Critical Hdwy	4.1	-	-	4.15	-	-	7.12	6.5	6.2	7.1	6.5	6.23
Critical Hdwy Stg 1	-	-	-	-	-	-	6.12	5.5	-	6.1	5.5	-
Critical Hdwy Stg 2	-	-	-	-	-	-	6.12	5.5	-	6.1	5.5	-
Follow-up Hdwy	2.2	-	-	2.245	-	-	3.518	4	3.3	3.5	4	3.327
Pot Cap-1 Maneuver	694	-	-	959	-	-	76	98	498	75	99	290
Stage 1	-	-	-	-	-	-	474	482	-	284	313	-
Stage 2	-	-	-	-	-	-	276	309	-	457	479	-
Platoon blocked, %	-	-	-	-	-	-	-	-	-	-	-	-
Mov Cap-1 Maneuver	685	-	-	947	-	-	60	90	487	57	91	283
Mov Cap-2 Maneuver	-	-	-	-	-	-	60	90	-	57	91	-
Stage 1	-	-	-	-	-	-	457	465	-	274	298	-
Stage 2	-	-	-	-	-	-	231	294	-	378	462	-

Approach	EB	WB	NB	SB
HCM Control Delay, s	0.2	0.1	191.5	40.7
HCM LOS			F	E

Minor Lane/Major Mvmt	NBLn1	EBL	EBT	EBR	WBL	WBT	WBR	SBLn1
Capacity (veh/h)	111	685	-	-	947	-	-	141
HCM Lane V/C Ratio	1.109	0.018	-	-	0.017	-	-	0.291
HCM Control Delay (s)	191.5	10.4	0	-	8.9	0	-	40.7
HCM Lane LOS	F	B	A	-	A	A	-	E
HCM 95th %tile Q(veh)	7.6	0.1	-	-	0.1	-	-	1.1

HCM 2010 TWSC
5: Ash St & SR-14

Intersection												
Int Delay, s/veh	3.9											

Movement	EBL	EBT	EBR	WBL	WBT	WBR	NBL	NBT	NBR	SBL	SBT	SBR
Traffic Vol, veh/h	25	485	10	5	850	10	0	0	0	20	0	80
Future Vol, veh/h	25	485	10	5	850	10	0	0	0	20	0	80
Conflicting Peds, #/hr	3	0	9	9	0	3	8	0	8	8	0	8
Sign Control	Free	Free	Free	Free	Free	Free	Stop	Stop	Stop	Stop	Stop	Stop
RT Channelized	-	-	None	-	-	None	-	-	None	-	-	None
Storage Length	-	-	-	-	-	-	-	-	-	-	-	-
Veh in Median Storage, #	-	0	-	-	0	-	-	0	-	-	0	-
Grade, %	-	0	-	-	0	-	-	0	-	-	0	-
Peak Hour Factor	90	90	90	88	88	88	92	92	92	73	73	73
Heavy Vehicles, %	7	6	0	0	5	0	2	2	2	8	0	0
Mvmt Flow	28	539	11	6	966	11	0	0	0	27	0	110

Major/Minor	Major1			Major2			Minor2		
Conflicting Flow All	985	0	0	550	0	0	1591	1597	989
Stage 1	-	-	-	-	-	-	991	991	-
Stage 2	-	-	-	-	-	-	600	606	-
Critical Hdwy	4.17	-	-	4.1	-	-	6.48	6.5	6.2
Critical Hdwy Stg 1	-	-	-	-	-	-	5.48	5.5	-
Critical Hdwy Stg 2	-	-	-	-	-	-	5.48	5.5	-
Follow-up Hdwy	2.263	-	-	2.2	-	-	3.572	4	3.3
Pot Cap-1 Maneuver	682	-	-	1030	-	-	114	108	302
Stage 1	-	-	-	-	-	-	350	327	-
Stage 2	-	-	-	-	-	-	537	490	-
Platoon blocked, %	-	-	-	-	-	-	-	-	-
Mov Cap-1 Maneuver	676	-	-	1021	-	-	104	0	297
Mov Cap-2 Maneuver	-	-	-	-	-	-	104	0	-
Stage 1	-	-	-	-	-	-	343	0	-
Stage 2	-	-	-	-	-	-	501	0	-

Approach	EB	WB	SB
HCM Control Delay, s	0.5	0	46.3
HCM LOS			E

Minor Lane/Major Mvmt	EBL	EBT	EBR	WBL	WBT	WBR	SBLn1
Capacity (veh/h)	676	-	-	1021	-	-	217
HCM Lane V/C Ratio	0.041	-	-	0.006	-	-	0.631
HCM Control Delay (s)	10.6	0	-	8.5	0	-	46.3
HCM Lane LOS	B	A	-	A	A	-	E
HCM 95th %tile Q(veh)	0.1	-	-	0	-	-	3.7

HCM 2010 AWSC
6: Oak St & SR-14

Intersection												
Intersection Delay, s/veh	48.1											
Intersection LOS	E											
Movement	EBU	EBL	EBT	EBR	WBU	WBL	WBT	WBR	NBU	NBL	NBT	NBR
Traffic Vol, veh/h	0	210	290	10	0	10	480	245	0	20	20	20
Future Vol, veh/h	0	210	290	10	0	10	480	245	0	20	20	20
Peak Hour Factor	0.86	0.79	0.79	0.79	0.91	0.90	0.90	0.90	0.92	0.83	0.83	0.83
Heavy Vehicles, %	1	3	12	50	0	0	7	2	2	13	4	0
Mvmt Flow	0	266	367	13	0	11	533	272	0	24	24	24
Number of Lanes	0	1	1	0	0	0	1	0	0	0	1	0
Approach	EB			WB			NB					
Opposing Approach	WB			EB			SB					
Opposing Lanes	1			2			2					
Conflicting Approach Left	SB			NB			EB					
Conflicting Lanes Left	2			1			2					
Conflicting Approach Right	NB			SB			WB					
Conflicting Lanes Right	1			2			1					
HCM Control Delay	33.6			70			15.3					
HCM LOS	D			F			C					
Lane	NBLn1	EBLn1	EBLn2	WBLn1	SBLn1	SBLn2						
Vol Left, %	33%	100%	0%	1%	100%	0%						
Vol Thru, %	33%	0%	97%	65%	0%	0%						
Vol Right, %	33%	0%	3%	33%	0%	100%						
Sign Control	Stop	Stop	Stop	Stop	Stop	Stop						
Traffic Vol by Lane	60	210	300	735	100	355						
LT Vol	20	210	0	10	100	0						
Through Vol	20	0	290	480	0	0						
RT Vol	20	0	10	245	0	355						
Lane Flow Rate	72	266	380	817	123	438						
Geometry Grp	6	7	7	6	7	7						
Degree of Util (X)	0.197	0.616	0.84	1	0.293	0.883						
Departure Headway (Hd)	9.813	8.336	7.965	7.687	8.541	7.257						
Convergence, Y/N	Yes	Yes	Yes	Yes	Yes	Yes						
Cap	364	433	456	474	421	500						
Service Time	7.905	6.104	5.733	5.783	6.291	5.006						
HCM Lane V/C Ratio	0.198	0.614	0.833	1.724	0.292	0.876						
HCM Control Delay	15.3	23.7	40.6	70	14.8	43.6						
HCM Lane LOS	C	C	E	F	B	E						
HCM 95th-tile Q	0.7	4	8.2	13.2	1.2	9.7						

HCM 2010 AWSC
6: Oak St & SR-14

Intersection

Intersection Delay, s/veh

Intersection LOS

Movement	SBU	SBL	SBT	SBR
Traffic Vol, veh/h	0	100	0	355
Future Vol, veh/h	0	100	0	355
Peak Hour Factor	0.92	0.81	0.81	0.81
Heavy Vehicles, %	2	5	0	1
Mvmt Flow	0	123	0	438
Number of Lanes	0	0	1	1

Approach SB

Opposing Approach NB

Opposing Lanes 1

Conflicting Approach Left WB

Conflicting Lanes Left 1

Conflicting Approach Right EB

Conflicting Lanes Right 2

HCM Control Delay 37.3

HCM LOS E

Lane

HCM 2010 AWSC
7: Maple St & SR-14

Intersection												
Intersection Delay, s/veh	42.2											
Intersection LOS	E											
Movement	EBU	EBL	EBT	EBR	WBU	WBL	WBT	WBR	NBU	NBL	NBT	NBR
Traffic Vol, veh/h	0	10	385	20	0	5	625	5	0	95	5	25
Future Vol, veh/h	0	10	385	20	0	5	625	5	0	95	5	25
Peak Hour Factor	0.92	0.92	0.92	0.92	0.92	0.87	0.87	0.87	0.92	0.86	0.86	0.86
Heavy Vehicles, %	2	0	9	7	2	22	7	0	2	2	0	6
Mvmt Flow	0	11	418	22	0	6	718	6	0	110	6	29
Number of Lanes	0	0	1	1	0	0	1	0	0	0	1	1
Approach	EB				WB				NB			
Opposing Approach	WB				EB				SB			
Opposing Lanes	1				2				1			
Conflicting Approach Left	SB				NB				EB			
Conflicting Lanes Left	1				2				2			
Conflicting Approach Right	NB				SB				WB			
Conflicting Lanes Right	2				1				1			
HCM Control Delay	20.8				62.4				12.5			
HCM LOS	C				F				B			
Lane	NBLn1	NBLn2	EBLn1	EBLn2	WBLn1	SBLn1						
Vol Left, %	95%	0%	3%	0%	1%	25%						
Vol Thru, %	5%	0%	97%	0%	98%	25%						
Vol Right, %	0%	100%	0%	100%	1%	50%						
Sign Control	Stop	Stop	Stop	Stop	Stop	Stop						
Traffic Vol by Lane	100	25	395	20	635	20						
LT Vol	95	0	10	0	5	5						
Through Vol	5	0	385	0	625	5						
RT Vol	0	25	0	20	5	10						
Lane Flow Rate	116	29	429	22	730	27						
Geometry Grp	7	7	7	7	6	6						
Degree of Util (X)	0.253	0.054	0.704	0.032	1	0.057						
Departure Headway (Hd)	7.848	6.641	5.902	5.343	6.244	7.611						
Convergence, Y/N	Yes	Yes	Yes	Yes	Yes	Yes						
Cap	459	541	614	673	584	472						
Service Time	5.565	4.357	3.614	3.054	4.266	5.638						
HCM Lane V/C Ratio	0.253	0.054	0.699	0.033	1.25	0.057						
HCM Control Delay	13.2	9.7	21.4	8.2	62.4	11.1						
HCM Lane LOS	B	A	C	A	F	B						
HCM 95th-tile Q	1	0.2	5.7	0.1	14.7	0.2						

HCM 2010 AWSC
7: Maple St & SR-14

Intersection

Intersection Delay, s/veh
Intersection LOS

Movement	SBU	SBL	SBT	SBR
Traffic Vol, veh/h	0	5	5	10
Future Vol, veh/h	0	5	5	10
Peak Hour Factor	0.92	0.74	0.74	0.74
Heavy Vehicles, %	2	0	0	3
Mvmt Flow	0	7	7	14
Number of Lanes	0	0	1	0

Approach

Approach	SB
Opposing Approach	NB
Opposing Lanes	2
Conflicting Approach Left	WB
Conflicting Lanes Left	1
Conflicting Approach Right	EB
Conflicting Lanes Right	2
HCM Control Delay	11.1
HCM LOS	B

Lane

HCM 2010 Roundabout
28: SR-14

Intersection				
Intersection Delay, s/veh	10.7			
Intersection LOS	B			
Approach	EB	WB	NB	SB
Entry Lanes	1	1	1	1
Conflicting Circle Lanes	1	1	1	1
Adj Approach Flow, veh/h	456	434	321	54
Demand Flow Rate, veh/h	496	465	330	55
Vehicles Circulating, veh/h	38	255	466	710
Vehicles Exiting, veh/h	727	541	68	10
Follow-Up Headway, s	3.186	3.186	3.186	3.186
Ped Vol Crossing Leg, #/h	0	0	0	0
Ped Cap Adj	1.000	1.000	1.000	1.000
Approach Delay, s/veh	8.9	11.9	12.0	7.8
Approach LOS	A	B	B	A
Lane	Left	Left	Left	Left
Designated Moves	LTR	LTR	LTR	LTR
Assumed Moves	LTR	LTR	LTR	LTR
RT Channelized				
Lane Util	1.000	1.000	1.000	1.000
Critical Headway, s	5.193	5.193	5.193	5.193
Entry Flow, veh/h	496	465	330	55
Cap Entry Lane, veh/h	1088	876	709	556
Entry HV Adj Factor	0.919	0.934	0.973	0.982
Flow Entry, veh/h	456	434	321	54
Cap Entry, veh/h	1000	818	690	545
V/C Ratio	0.456	0.531	0.465	0.099
Control Delay, s/veh	8.9	11.9	12.0	7.8
LOS	A	B	B	A
95th %tile Queue, veh	2	3	2	0